

The Difluoromethyl Group: A Multifaceted Tool in Bioactive Compound Design

Author: BenchChem Technical Support Team. **Date:** May 2026

Compound of Interest

Compound Name:	5-Chloro-2-(difluoromethyl)pyridine-3-carboxylic acid
CAS No.:	1256794-46-3
Cat. No.:	B1475074

[Get Quote](#)

An In-depth Technical Guide for Researchers, Scientists, and Drug Development Professionals

Introduction: The Rise of a Unique Bioisostere

In the landscape of medicinal chemistry, the strategic incorporation of fluorine-containing functional groups has become a cornerstone of modern drug design.[1] Among these, the difluoromethyl (CF₂H) group has emerged as a moiety of significant interest, offering a unique combination of physicochemical properties that can profoundly influence the biological activity of a molecule.[2] This guide provides a comprehensive technical overview of the role of the difluoromethyl group in bioactivity, delving into its fundamental characteristics, strategic applications, and the experimental methodologies used to evaluate its impact.

The CF₂H group is often considered a "lipophilic hydrogen bond donor," a descriptor that encapsulates its dual nature.[3] It can act as a bioisostere for common functional groups such as hydroxyl (OH), thiol (SH), and amine (NH₂) groups, while simultaneously modulating lipophilicity and metabolic stability.[4][5] This multifaceted character allows medicinal chemists

to fine-tune the properties of lead compounds to enhance their pharmacokinetic and pharmacodynamic profiles.[6]

Physicochemical Properties and Their Biological Implications

The influence of the difluoromethyl group on a molecule's bioactivity stems from its distinct electronic and steric properties. Understanding these is crucial for its rational application in drug design.

Hydrogen Bonding Capacity: A "Lipophilic" Donor

A key feature of the CF₂H group is its ability to act as a hydrogen bond donor. The two highly electronegative fluorine atoms withdraw electron density from the C-H bond, making the hydrogen atom sufficiently acidic to participate in hydrogen bonding interactions with biological targets.[6] This capacity has been quantified using Abraham's solute ¹H NMR analysis, where the difference in the chemical shift of the CF₂H proton in deuterated DMSO and CDCl₃ correlates to its hydrogen bond acidity ([A]).[7] Studies have shown that compounds bearing a CF₂H group are significantly better hydrogen-bond donors than their methyl (CH₃) analogues.[7] For instance, ArOCF₂H and ArSCF₂H exhibit hydrogen bond acidity similar to thiophenol and aniline.[7]

This hydrogen bonding ability allows the CF₂H group to serve as a bioisostere for traditional hydrogen bond donors like hydroxyl and thiol groups, potentially mimicking key interactions within a protein binding site.[3][4] An example of this is seen in the mTORC1/2 selective inhibitor PQR620, where the CF₂H group forms a crucial hydrogen bond with Glu2190 of mTOR, contributing to its high selectivity.[7]

Experimental Protocol: Determination of Hydrogen Bond Acidity (A) via ¹H NMR

This protocol outlines the steps to quantify the hydrogen bond donor capacity of a difluoromethyl-containing compound.

Objective: To determine the Abraham hydrogen bond acidity parameter (A).

Materials:

- Test compound containing a CF₂H group
- Deuterated chloroform (CDCl₃)
- Deuterated dimethyl sulfoxide (DMSO-d₆)
- NMR spectrometer (e.g., 400 MHz or higher)
- High-precision NMR tubes

Procedure:

- Sample Preparation:
 - Prepare two separate NMR samples of the test compound at the same concentration (e.g., 5-10 mg/mL).
 - Dissolve the first sample in CDCl₃.
 - Dissolve the second sample in DMSO-d₆.
- NMR Data Acquisition:
 - Acquire a ¹H NMR spectrum for each sample.
 - Ensure high resolution and accurate chemical shift referencing (e.g., using residual solvent peaks).
- Data Analysis:
 - Identify the chemical shift (δ) of the CF₂H proton in both spectra.
 - Calculate the difference in chemical shift: $\Delta\delta = \delta(\text{DMSO-d}_6) - \delta(\text{CDCl}_3)$.
- Calculation of Hydrogen Bond Acidity (A):
 - Use the following empirical equation to calculate the A value: $A = 0.0065 + 0.133 * \Delta\delta$ ^[7]

Interpretation:

- A higher A value indicates a stronger hydrogen bond donor capacity.
- Compare the calculated A value to known values for other functional groups to assess its relative strength.

Lipophilicity: A Context-Dependent Parameter

The introduction of fluorine is generally associated with an increase in lipophilicity. However, the effect of the difluoromethyl group on the logarithm of the partition coefficient (logP), a measure of lipophilicity, is more nuanced and context-dependent.[6] While often considered a lipophilicity-enhancing group, the change in logP upon replacing a methyl group with a difluoromethyl group ($\Delta\log P$) can range from a slight decrease to a moderate increase.[3] For example, in a series of difluoromethyl anisoles and thioanisoles, the experimental $\Delta\log P$ values spanned from -0.1 to +0.4.[3]

This variability arises from a combination of factors, including the electronic environment of the CF₂H group and its conformational effects.[6] For instance, with electron-withdrawing groups on an aromatic ring, replacing a methyl group with a difluoromethyl group can lead to a decrease in lipophilicity.[6] This highlights the importance of experimental determination of lipophilicity for each new compound.

Functional Group Comparison	Typical $\Delta\log P$ (CF ₂ H vs. CH ₃)	Reference
Aryl-OCH ₃ vs. Aryl-OCF ₂ H	-0.1 to +0.4	[3]
Alkyl-CH ₃ vs. Alkyl-CF ₂ H	Generally positive	[6]
Aryl-SO ₂ CH ₃ vs. Aryl-SO ₂ CF ₂ H	~ +1.2	[6]

Conformational Effects: Influencing Binding and Permeability

The difluoromethyl group can also exert significant conformational effects on a molecule, which can impact its binding to a biological target and its ability to permeate cell membranes.[7] In aromatic ethers, for example, the conformational preference of a methoxy group (ArOCH₃) is

generally coplanar with the aromatic ring. In contrast, a trifluoromethoxy group (ArOCF_3) prefers an orthogonal orientation.^[7] The difluoromethoxy group (ArOCF_2H) is unique in that it has no strong orientational preference and can adopt various conformations.^[7] This conformational flexibility allows a molecule to better adapt to the specific geometry of a binding pocket, potentially leading to enhanced affinity.^[7]

Intramolecular hydrogen bonds (IMHBs) involving the CF_2H group can also play a role in stabilizing specific conformations.^[6] These IMHBs can mask polar groups, which may positively impact membrane permeability and solubility.^[6]

The Difluoromethyl Group as a Bioisostere

Bioisosteric replacement is a key strategy in drug discovery to improve the properties of a lead compound while maintaining its biological activity. The CF_2H group is a versatile bioisostere for several common functional groups.

Bioisostere for Hydroxyl (OH), Thiol (SH), and Amine (NH₂) Groups

The ability of the CF_2H group to act as a hydrogen bond donor makes it a suitable bioisostere for hydroxyl, thiol, and primary amine groups.^{[4][5]} A significant advantage of this replacement is the enhanced metabolic stability of the CF_2H group compared to these other functionalities, which are often susceptible to oxidation or conjugation reactions.^{[4][8]}

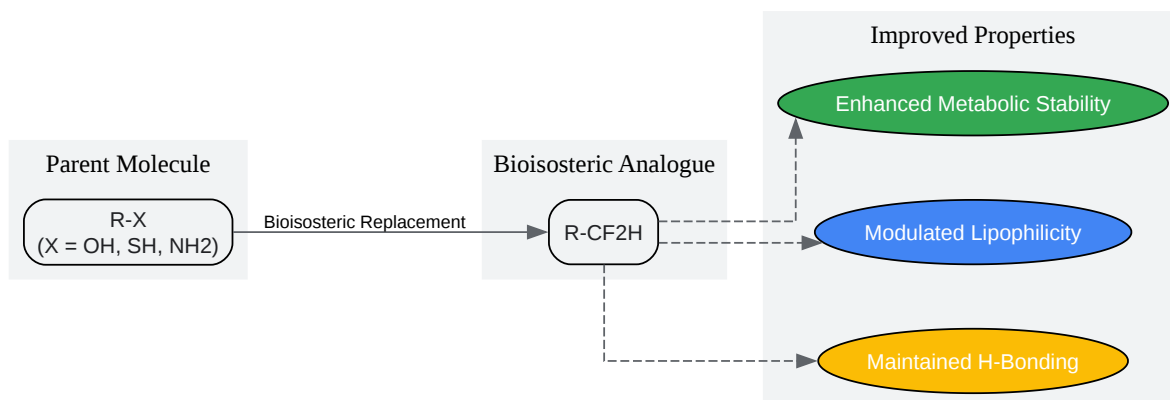

[Click to download full resolution via product page](#)

Caption: Bioisosteric replacement of OH, SH, or NH₂ with CF₂H.

Surrogate for Methyl (CH₃) and Trifluoromethyl (CF₃) Groups

The CF₂H group can also be considered a surrogate for the methyl (CH₃) and trifluoromethyl (CF₃) groups.[6] Replacing a methyl group with a difluoromethyl group can introduce a new hydrogen bonding interaction, which may increase binding affinity.[1] Compared to the more lipophilic trifluoromethyl group, the difluoromethyl group often results in a smaller increase in lipophilicity, which can be advantageous for optimizing the overall physicochemical profile of a drug candidate.[1]

Impact on Bioactivity: Case Studies

The strategic incorporation of the difluoromethyl group has led to the development of several successful drugs and promising clinical candidates.

- **Benzoxaboroles as Antimicrobials:** The introduction of a difluoromethyl group at the C3 position of benzoxaboroles, a class of compounds with antimicrobial activity, resulted in

enhanced bioactivity against *E. coli*.^[9] The CF₂H group acts as a stable hydrogen bond donor, mimicking the activity of the synthetically challenging 3-hydroxy analogues.^[9]^[10]

- **Enzyme Inhibitors:** In the design of enzyme inhibitors, the CF₂H group can form key interactions with active site residues. As mentioned earlier, the mTOR inhibitor PQR620 utilizes a CF₂H group to achieve high selectivity through a specific hydrogen bond.^[7]
- **Pesticides:** The difluoromethyl group is also increasingly used in the design of new pesticides.^[11] For example, diflumetorim is a fungicide that contains a difluoromethyl-pyrimidine moiety.^[11]

Synthetic Methodologies for Introducing the Difluoromethyl Group

The growing importance of the CF₂H group has spurred the development of various synthetic methods for its introduction into organic molecules. These methods can be broadly categorized into nucleophilic, electrophilic, and radical approaches.

Nucleophilic Difluoromethylation

These methods involve the use of a difluoromethyl anion equivalent, such as that generated from (difluoromethyl)trimethylsilane (TMSCF₂H) in the presence of a base.^[12] This approach is useful for the difluoromethylation of carbonyl compounds and other electrophiles.^[9]

Experimental Protocol: Nucleophilic Difluoromethylation of an Aldehyde

Objective: To synthesize a difluoromethylated alcohol from an aldehyde using TMSCF₂H.

Materials:

- Aldehyde substrate
- (Difluoromethyl)trimethylsilane (TMSCF₂H)
- Potassium tert-butoxide (KOtBu)
- Anhydrous tetrahydrofuran (THF)

- Anhydrous dimethoxyethane (DME)
- Inert atmosphere (e.g., argon or nitrogen)
- Standard glassware for anhydrous reactions

Procedure:

- Reaction Setup:
 - Under an inert atmosphere, add the aldehyde substrate to a solution of K_{Ot}Bu in a mixture of anhydrous THF and DME at -55 °C.[9]
- Addition of Difluoromethylating Agent:
 - Slowly add TMSCF₂H to the reaction mixture.
- Reaction Progression:
 - Allow the reaction to slowly warm to room temperature and stir for several hours (e.g., 18 hours).[9]
- Workup and Purification:
 - Quench the reaction with a saturated aqueous solution of ammonium chloride.
 - Extract the product with an organic solvent (e.g., ethyl acetate).
 - Dry the organic layer over anhydrous sodium sulfate, filter, and concentrate under reduced pressure.
 - Purify the crude product by column chromatography on silica gel.

Radical Difluoromethylation

Radical difluoromethylation methods have gained prominence due to their ability to directly functionalize C-H bonds. These reactions typically involve the generation of a difluoromethyl radical ($\bullet\text{CF}_2\text{H}$) from a suitable precursor, such as bromodifluoromethane (BrCF_2H) or

difluoromethyl sulfonates, often using photoredox catalysis.[12] This approach allows for the late-stage difluoromethylation of complex molecules, including drugs and natural products.[5]

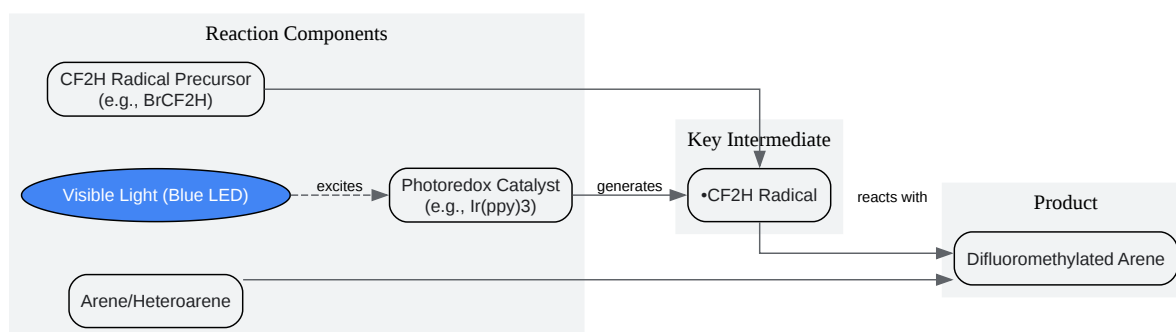

[Click to download full resolution via product page](#)

Need Custom Synthesis?

BenchChem offers custom synthesis for rare earth carbides and specific isotopic labeling.

Email: info@benchchem.com or [Request Quote Online](#).

Sources

- 1. alfa-chemistry.com [alfa-chemistry.com]
- 2. researchgate.net [researchgate.net]
- 3. pubs.acs.org [pubs.acs.org]
- 4. Facile Entry to Pharmaceutically Important 3-Difluoromethyl-Quinoxalin-2-Ones Enabled by Visible-Light-Driven Difluoromethylation of Quinoxalin-2-Ones - PMC [pmc.ncbi.nlm.nih.gov]
- 5. Introduction of the difluoromethyl group at the meta- or para-position of pyridines through regioselectivity switch - PMC [pmc.ncbi.nlm.nih.gov]

- [6. CF₂H: a fascinating group for application in drug development enabling modulation of many molecular properties - PMC \[pmc.ncbi.nlm.nih.gov\]](#)
- [7. Late-stage difluoromethylation: concepts, developments and perspective - Chemical Society Reviews \(RSC Publishing\) DOI:10.1039/D1CS00360G \[pubs.rsc.org\]](#)
- [8. researchgate.net \[researchgate.net\]](#)
- [9. pubs.acs.org \[pubs.acs.org\]](#)
- [10. pubs.acs.org \[pubs.acs.org\]](#)
- [11. pubs.acs.org \[pubs.acs.org\]](#)
- [12. alfa-chemistry.com \[alfa-chemistry.com\]](#)
- To cite this document: BenchChem. [The Difluoromethyl Group: A Multifaceted Tool in Bioactive Compound Design]. BenchChem, [2026]. [Online PDF]. Available at: [\[https://www.benchchem.com/product/b1475074/docs#the-difluoromethyl-group-a-multifaceted-tool-in-bioactive-compound-design\]](https://www.benchchem.com/product/b1475074/docs#the-difluoromethyl-group-a-multifaceted-tool-in-bioactive-compound-design)

Disclaimer & Data Validity:

The information provided in this document is for Research Use Only (RUO) and is strictly not intended for diagnostic or therapeutic procedures. While BenchChem strives to provide accurate protocols, we make no warranties, express or implied, regarding the fitness of this product for every specific experimental setup.

Technical Support: The protocols provided are for reference purposes. Unsure if this reagent suits your experiment?

Need Industrial/Bulk Grade? [Request Custom Synthesis Quote](#)

BenchChem

Our mission is to be the trusted global source of essential and advanced chemicals, empowering scientists and researchers to drive progress in science and industry.

Contact

Address: 3281 E Guasti Rd
Ontario, CA 91761, United States
Phone: (601) 213-4426
Email: info@benchchem.com

Contact our Ph.D. Support Team for a compatibility check