

Technical Support Center: Optimizing Catalyst Loading for 4-Bromopyrimidine Reactions

Author: BenchChem Technical Support Team. **Date:** April 2026

Compound of Interest

Compound Name: 4-Bromo-6-(4-(tert-butyl)phenyl)pyrimidine

CAS No.: 1774802-71-9

Cat. No.: B1475600

[Get Quote](#)

Welcome to the technical support center for palladium-catalyzed cross-coupling reactions involving 4-bromopyrimidine. This guide is designed for researchers, scientists, and drug development professionals to navigate the specific challenges associated with this substrate. Pyrimidine cores are ubiquitous in pharmaceuticals and bioactive molecules, making their functionalization a critical task.^{[1][2]} However, the 4-bromopyrimidine scaffold presents unique hurdles, primarily due to the potential for the pyridine nitrogen to coordinate with the palladium catalyst, leading to deactivation or the formation of inactive complexes.^{[3][4]}

This resource provides in-depth, field-proven insights in a direct question-and-answer format to help you troubleshoot common issues, optimize your catalyst loading, and achieve robust, reproducible results.

Part 1: Frequently Asked Questions (FAQs)

This section addresses high-level, common questions that arise when planning or initiating reactions with 4-bromopyrimidine.

Q1: Why are my cross-coupling reactions with 4-bromopyrimidine resulting in low or no yield?

A: Low yields with this substrate are common and typically stem from a few core issues:

- **Catalyst Inhibition/Deactivation:** This is the most frequent culprit. The lone pair of electrons on the pyrimidine nitrogen can coordinate to the palladium center. This can form stable, "off-cycle" complexes that are catalytically inactive, effectively poisoning your reaction.^[4] The result is often a stalled reaction that fails to reach completion.
- **Inactive Catalyst Formation:** The active Pd(0) species may not be forming efficiently from your Pd(II) precatalyst, or it may be decomposing. This can be due to the presence of oxygen or impurities in your reagents or solvents.^{[4][5]} The formation of a black precipitate ("palladium black") is a visual indicator of the aggregation of Pd(0) into an inactive state.^{[4][6]}
- **Suboptimal Reaction Parameters:** The choice of ligand, base, and solvent is exceptionally critical for heteroaromatic substrates. An inappropriate combination can fail to promote the key steps of the catalytic cycle—oxidative addition, transmetalation (in Suzuki coupling), or reductive elimination.^{[7][8]}
- **Poor Reagent Solubility:** If the 4-bromopyrimidine, coupling partner, or base has poor solubility in the chosen solvent, the reaction kinetics will be severely hindered.^{[5][9]}

Q2: What is the best "first-pass" catalyst system to screen for a Suzuki-Miyaura coupling with 4-bromopyrimidine?

A: For an initial screen, it is wise to start with a robust and well-documented system. A combination of a palladium source and a suitable ligand is key.

- **Palladium Source:** A common and effective starting point is Pd(PPh₃)₄ (tetrakis(triphenylphosphine)palladium(0)) at a loading of 2-5 mol %.^{[10][11]} This is a pre-formed Pd(0) catalyst, which can sometimes be more reliable for initiating the reaction.^[5] Alternatively, a Pd(II) source like Pd(OAc)₂ or Pd₂(dba)₃ (tris(dibenzylideneacetone)dipalladium(0)) paired with a phosphine ligand is a versatile choice.
- **Ligand:** For Suzuki couplings, triphenylphosphine (as part of Pd(PPh₃)₄) is a classic choice. If that fails, moving to more electron-rich and bulky biarylphosphine ligands like XPhos or

SPhos can facilitate the oxidative addition and reductive elimination steps, which are often challenging with heteroaromatic halides.[3]

- Base & Solvent: A standard starting condition is K_3PO_4 or K_2CO_3 as the base in a solvent system of 1,4-dioxane and water.[5][11] The water is often crucial for activating the boronic acid to facilitate transmetalation.[5][12]

Q3: What are the most common side reactions, and how can they be minimized?

A: Two side reactions are particularly prevalent:

- Hydrodehalogenation: This is the replacement of the bromine atom with a hydrogen atom, resulting in an unsubstituted pyrimidine byproduct. This can occur when a hydride source is present (e.g., solvent, base, or water) and is often promoted by the palladium catalyst.[7]
 - Mitigation: Avoid protic solvents like alcohols if this is a major issue; use aprotic solvents like 1,4-dioxane or toluene instead.[5] Careful selection of the phosphine ligand can also reduce the likelihood of this side reaction.[5]
- Homocoupling of Boronic Acid: This side reaction forms a biaryl byproduct from two molecules of your boronic acid coupling partner. It is typically caused by the presence of oxygen, which can oxidize the active Pd(0) catalyst to Pd(II), a species that can promote this unwanted reaction.[5][7]
 - Mitigation: Rigorous degassing of all solvents and the reaction mixture is critical.[5] Maintaining a strict inert atmosphere (argon or nitrogen) throughout the experiment is mandatory.[5] Using boronate esters (e.g., pinacol esters) instead of boronic acids can also help, as they release the boronic acid more slowly into the reaction.[5]

Part 2: Troubleshooting Guide

This section provides a systematic approach to diagnosing and solving specific experimental issues.

Observation / Problem	Potential Cause(s)	Recommended Solutions & Actions
CC-PYR-001: Reaction mixture turns black and a precipitate forms.	Catalyst Deactivation/Decomposition. The black solid is typically "palladium black," which consists of inactive, agglomerated Pd(0) particles. [4][6] This is often caused by high temperatures, a low ligand-to-palladium ratio, or the presence of oxygen.	<ol style="list-style-type: none">1. Stabilize the Catalyst: Use bulky, electron-rich phosphine ligands (e.g., biarylphosphines like XPhos) which protect the palladium center and prevent aggregation.[3][6]2. Ensure Inert Atmosphere: Rigorously degas all solvents and maintain a positive pressure of argon or nitrogen throughout the reaction.[5][6]3. Control Temperature: Lowering the reaction temperature can sometimes prevent catalyst decomposition.[6]
CC-PYR-002: Reaction starts but stalls before completion (e.g., 30-50% conversion).	<ol style="list-style-type: none">1. Catalyst Inhibition: The pyrimidine nitrogen is likely binding to the palladium, removing it from the catalytic cycle.[4]2. Insufficiently Active Catalyst: The chosen ligand may not be electron-rich or bulky enough to promote the difficult oxidative addition or reductive elimination steps.[7]	<ol style="list-style-type: none">1. Add Fresh Catalyst: To confirm deactivation, add a fresh portion of catalyst to the stalled reaction. If it restarts, deactivation was the issue.[4]2. Screen Ligands: Switch to more advanced, sterically hindered ligands. For Suzuki, try SPhos or XPhos. For Buchwald-Hartwig amination, RuPhos or BrettPhos are excellent choices.[3]3. Use a Pre-catalyst: Palladium pre-catalysts are designed for stability and efficient generation of the active Pd(0) species, making them less susceptible to inhibition.[9][13]

CC-PYR-003: Significant formation of hydrodehalogenated byproduct.	1. Hydrogen Source: The solvent (e.g., alcohols), water, or even the amine/phosphine can act as a hydride source.[7] 2. Inappropriate Base/Solvent: Certain base and solvent combinations can promote this pathway.	1. Change Solvent: Switch from protic solvents (isopropanol, water) to aprotic solvents (1,4-dioxane, toluene, DMF).[5] 2. Screen Bases: Weaker bases might be less likely to promote the protonolysis of the C-Br bond. [5] 3. Lower Temperature: Reducing the reaction temperature can sometimes slow this side reaction more than the desired coupling.[5]
--	--	---

CC-PYR-004: Inconsistent yields between reaction batches.	1. Reagent Purity: Impurities in starting materials, particularly water or oxygen, can act as catalyst poisons.[3][6] 2. Inconsistent Catalyst Activity: The quality of the palladium precursor or ligand may vary. 3. Poor Mixing: Inadequate stirring can lead to localized concentration gradients and side reactions, especially with heterogeneous bases.[14]	1. Use High-Purity Reagents: Use fresh, high-purity catalyst and ligands. Purify starting materials if necessary.[4] 2. Standardize Procedures: Ensure consistent degassing, inert atmosphere maintenance, reagent addition order, and vigorous stirring for every run. [6] 3. Consider Pre-catalysts: They often provide more reproducible results due to their stability and clean activation.[6][9]
---	--	--

Part 3: Visualization of Key Processes

Understanding the underlying mechanisms and workflows is crucial for effective troubleshooting.

The Suzuki-Miyaura Catalytic Cycle

The following diagram illustrates the key steps involved in a typical Suzuki-Miyaura cross-coupling reaction. Failure at any of these stages can lead to a poor outcome.

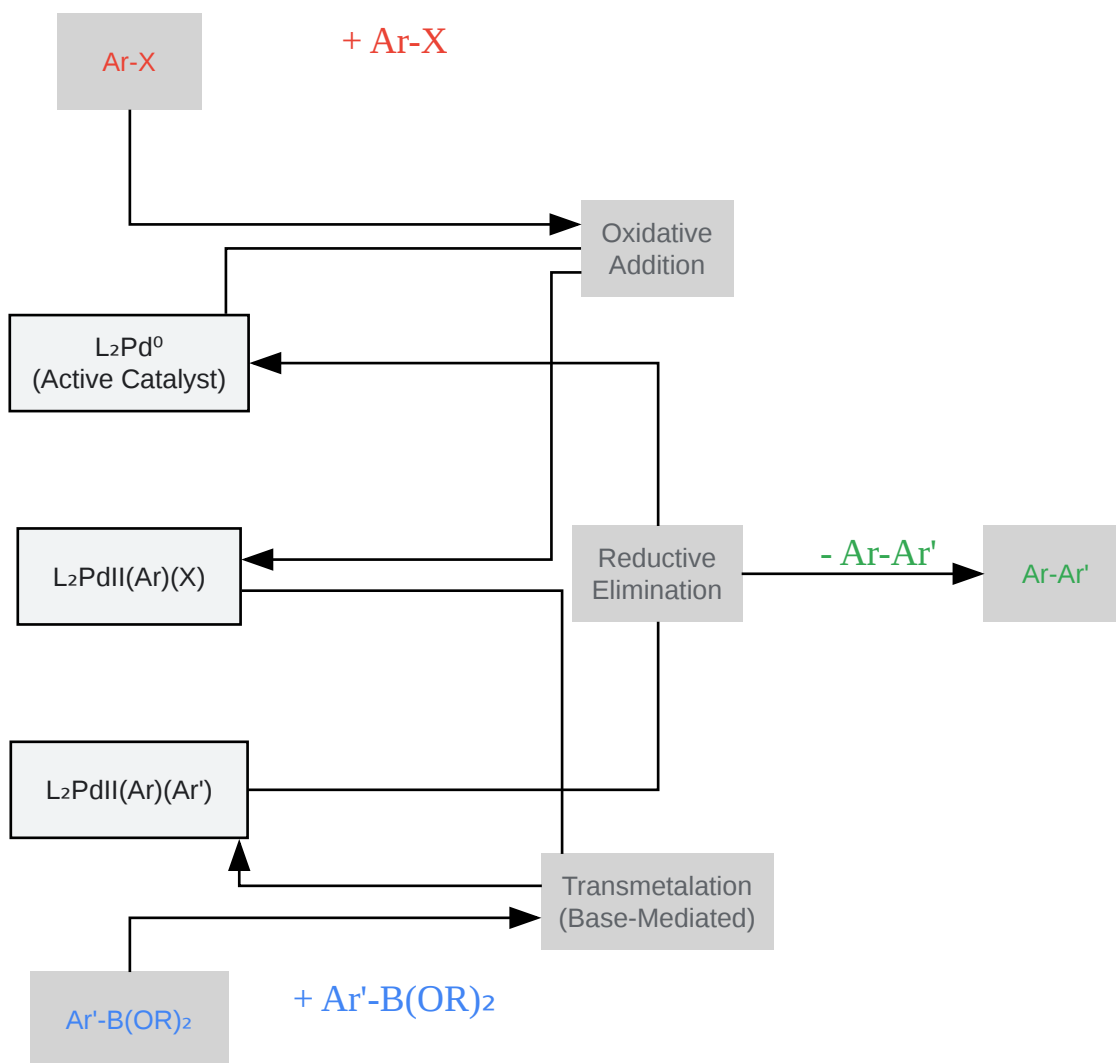

[Click to download full resolution via product page](#)

Caption: The catalytic cycle for the Suzuki-Miyaura reaction.[7][8]

Troubleshooting Workflow for 4-Bromopyrimidine Reactions

When a reaction fails, a structured approach is more effective than random screening. Use this decision tree to guide your optimization.

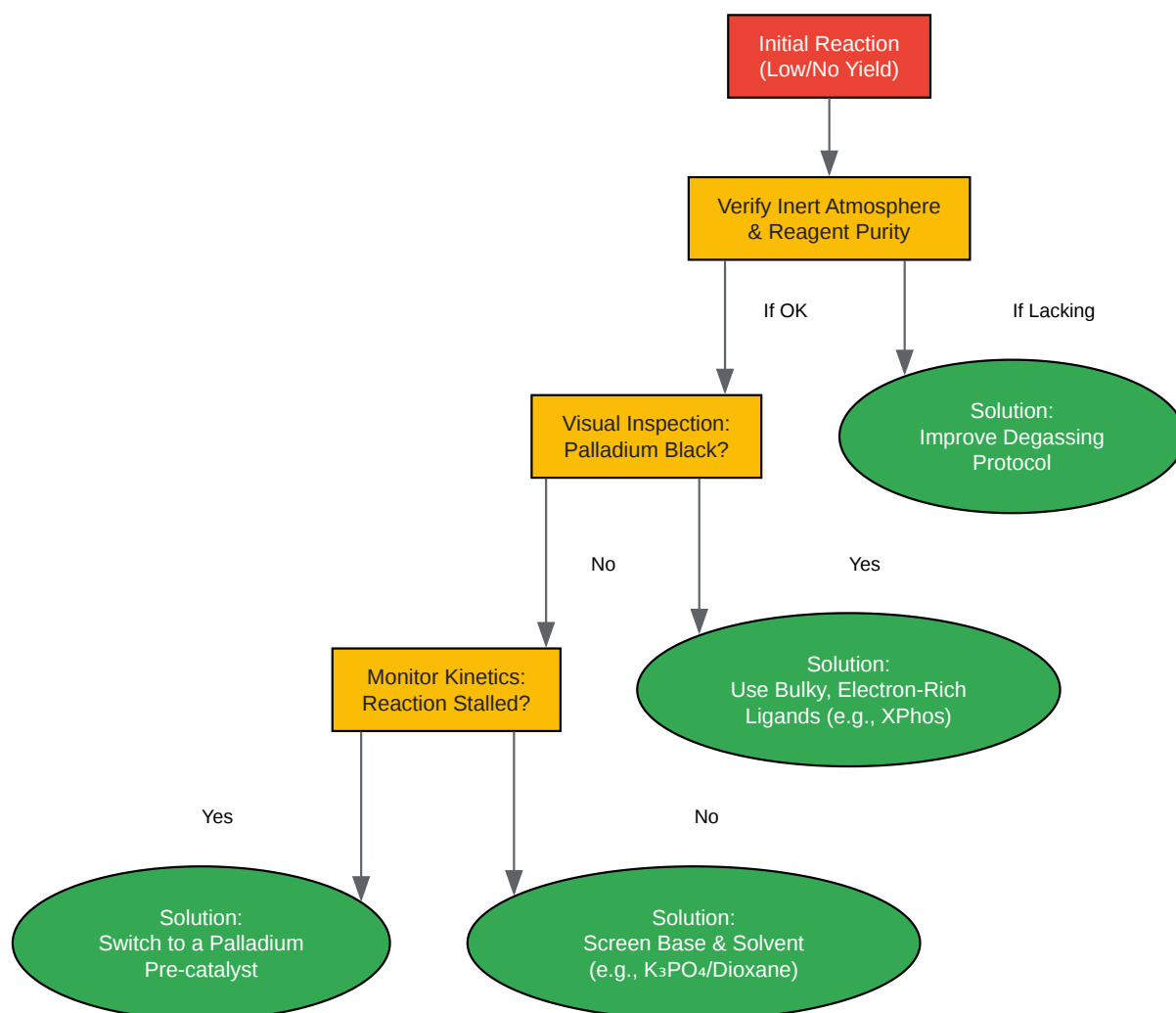

[Click to download full resolution via product page](#)

Need Custom Synthesis?

BenchChem offers custom synthesis for rare earth carbides and specific isotopic labeling.

Email: info@benchchem.com or [Request Quote Online](#).

Sources

- [1. C2-Selective Palladium-Catalyzed C—S Cross-Coupling of 2,4-Dihalopyrimidines - PMC \[pmc.ncbi.nlm.nih.gov\]](#)
- [2. jddtonline.info \[jddtonline.info\]](#)
- [3. pdf.benchchem.com \[pdf.benchchem.com\]](#)
- [4. pdf.benchchem.com \[pdf.benchchem.com\]](#)
- [5. pdf.benchchem.com \[pdf.benchchem.com\]](#)
- [6. pdf.benchchem.com \[pdf.benchchem.com\]](#)
- [7. Yoneda Labs \[yonedalabs.com\]](#)
- [8. chem.libretexts.org \[chem.libretexts.org\]](#)
- [9. Chemical Insights | How to Wisely Design Conditions for Buchwald-Hartwig Couplings ? - RCS Research Chemistry Services \[rcs.wuxiapptec.com\]](#)
- [10. researchgate.net \[researchgate.net\]](#)
- [11. mdpi.com \[mdpi.com\]](#)
- [12. Suzuki Coupling \[organic-chemistry.org\]](#)
- [13. pubs.acs.org \[pubs.acs.org\]](#)
- [14. sigmaaldrich.cn \[sigmaaldrich.cn\]](#)
- To cite this document: BenchChem. [Technical Support Center: Optimizing Catalyst Loading for 4-Bromopyrimidine Reactions]. BenchChem, [2026]. [Online PDF]. Available at: [\[https://www.benchchem.com/product/b1475600/docs#technical-support-center-optimizing-catalyst-loading-for-4-bromopyrimidine-reactions\]](https://www.benchchem.com/product/b1475600/docs#technical-support-center-optimizing-catalyst-loading-for-4-bromopyrimidine-reactions)

Disclaimer & Data Validity:

The information provided in this document is for Research Use Only (RUO) and is strictly not intended for diagnostic or therapeutic procedures. While BenchChem strives to provide accurate protocols, we make no warranties, express or implied, regarding the fitness of this product for every specific experimental setup.

Technical Support: The protocols provided are for reference purposes. Unsure if this reagent suits your experiment?

Need Industrial/Bulk Grade? [Request Custom Synthesis Quote](#)

BenchChem

Our mission is to be the trusted global source of essential and advanced chemicals, empowering scientists and researchers to drive progress in science and industry.

Contact

Address: 3281 E Guasti Rd

Ontario, CA 91761, United States

Phone: (601) 213-4426

Email: info@benchchem.com

[Contact our Ph.D. Support Team for a compatibility check](#)