

# Technical Support Center: Microwave-Assisted Pyrrolothiazole Synthesis

**Author:** BenchChem Technical Support Team. **Date:** April 2026

## Compound of Interest

Compound Name: 6-Methylpyrrolo[2,1-b][1,3]thiazole

CAS No.: 1122-34-5

Cat. No.: B14748808

[Get Quote](#)

Welcome to the Technical Support Center for Microwave-Assisted Organic Synthesis (MAOS) of pyrrolothiazoles. Pyrrolothiazoles are critical pharmacophores in drug development, often synthesized via multicomponent reactions such as 1,3-dipolar cycloadditions. While microwave irradiation drastically reduces reaction times and improves yields compared to conventional heating [1], researchers frequently encounter issues related to dielectric heating inefficiencies, localized superheating, and solvent incompatibility.

This guide is designed by application scientists to help you troubleshoot, optimize, and validate your microwave-assisted workflows.

## Diagnostic Workflow for Low Yields

Before adjusting your chemical equivalents, evaluate your physical microwave parameters. The flowchart below outlines the primary diagnostic logic for resolving poor conversion or high impurity profiles in MAOS.

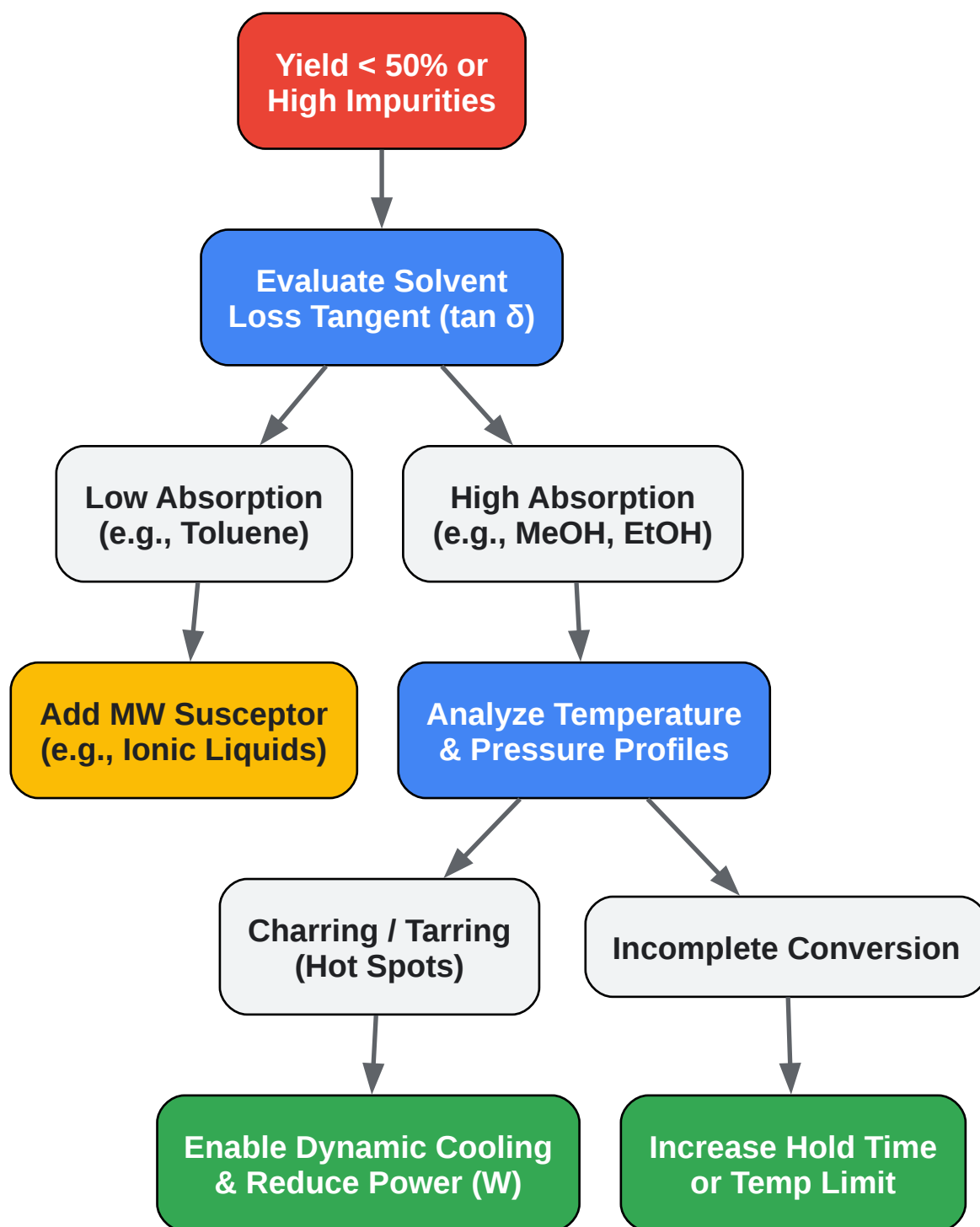

[Click to download full resolution via product page](#)

Diagnostic workflow for troubleshooting low yields in microwave-assisted pyrrolothiazole synthesis.

## Troubleshooting Guides & FAQs

### Q1: Why is my reaction mixture charring, resulting in a black tar and yields below 20%?

**Causality:** You are likely experiencing localized superheating, commonly known as "hot spots." Microwave energy couples directly with the dipoles of your polar reagents and solvent. If the solvent absorbs energy too rapidly without adequate dissipation, the extreme localized temperatures will degrade sensitive intermediates (like azomethine ylides) before the thermodynamic product can form. **Solution:** Enable Simultaneous Cooling (compressed air) on your microwave reactor. This allows the instrument to continuously input high microwave power (maintaining the activation energy required for the reaction) while the external cooling prevents the bulk temperature from exceeding the setpoint (e.g., 80 °C). Additionally, ensure maximum magnetic stirring speed to dissipate thermal gradients.

### Q2: Why does my synthesis stall at 50% conversion despite increasing the microwave hold time?

**Causality:** This is a classic symptom of a dropping dielectric loss tangent ( ) during the reaction. As highly polar precursors (like isatins and amino acids) are consumed to form less polar pyrrolothiazole products, the overall microwave absorbance of the solution decreases. If you are using a low-absorbing solvent, the reaction will literally "run out of heat" because the media can no longer absorb the microwave energy efficiently. **Solution:** Switch to a solvent with a high (such as Methanol or Ethanol) that will maintain the bulk heating regardless of reagent consumption [1]. Alternatively, spike the reaction with a microwave susceptor, such as 1-2 drops of an ionic liquid.

### Q3: I am using an enaminone precursor in acetic acid. Why am I getting pyrrolo[2,1-b]thiazol-6-ones instead of the expected 5-carboxylates?

**Causality:** Microwave irradiation can fundamentally alter the kinetic versus thermodynamic pathways of a reaction due to rapid, uniform heating profiles. Research has shown that conventional heating of enaminones in acetic acid produces ethyl pyrrolo[2,1-b]thiazole-5-

carboxylates, whereas microwave-assisted reactions in the exact same solvent drive the reaction toward pyrrolo[2,1-b]thiazol-6-ones in high yields [2]. Solution: This is a feature of MAOS, not a bug. If the 5-carboxylate is your target, you must revert to conventional thermal heating. If the 6-one is desired, maintain the microwave protocol.

## Self-Validating Experimental Protocol

To ensure reproducibility, follow this standardized, self-validating protocol for the synthesis of spiro-pyrrolothiazoles via a multicomponent 1,3-dipolar cycloaddition [1].

**Step 1: Reagent Preparation** In a 10 mL heavy-walled microwave vial, combine equimolar amounts (1.0 mmol) of substituted isatin, a secondary amino acid (e.g., L-proline or thiazolidine-4-carboxylic acid), and a substituted chalcone.

**Step 2: Solvent Selection** Add 3.0 mL of HPLC-grade Methanol. Methanol is chosen specifically for its high loss tangent (

= 0.659), which guarantees rapid dielectric heating. Add a Teflon-coated magnetic stir bar and seal the vial with a septum crimp cap.

**Step 3: Microwave Parameters** Program the microwave synthesizer with the following parameters:

- Power: Dynamic (Max 100 W)
- Temperature: 80 °C
- Ramp Time: 1 minute
- Hold Time: 5 minutes
- Cooling: Compressed air enabled (Simultaneous cooling).

**Step 4: Validation Check (Critical)** Self-Validation System: Do not proceed to workup without verifying intermediate consumption. Post-irradiation, cool the vial to 25 °C. Spot the crude mixture on a silica TLC plate alongside the starting chalcone (Eluent: Hexane/EtOAc 3:1).

- Pass: The disappearance of the bright yellow chalcone spot and the appearance of a new UV-active spot at [redacted] confirms successful ylide trapping.
- Fail: If the chalcone spot remains intense, the decarboxylation failed. Verify the microwave power output and ensure the amino acid was not degraded by moisture.

Step 5: Workup Pour the validated mixture into 15 mL of ice-cold water. Filter the resulting precipitate and recrystallize from hot ethanol to yield the pure spiro-pyrrolothiazole (Expected yield: 85–98%).

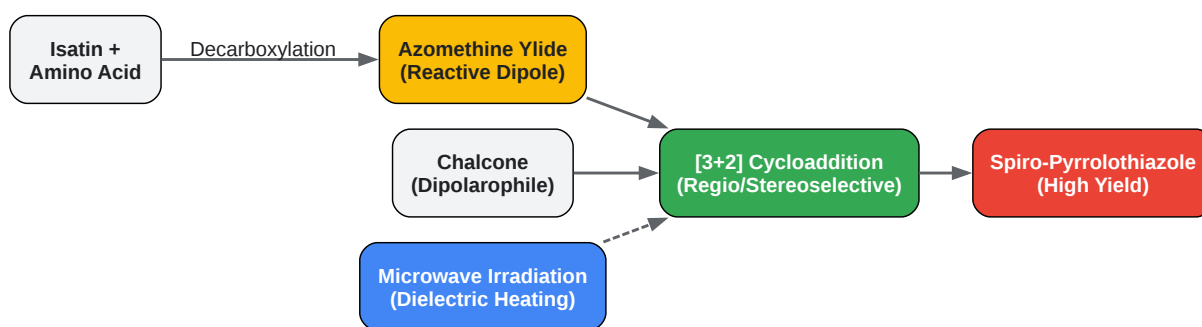

[Click to download full resolution via product page](#)

Mechanistic pathway of microwave-assisted [3+2] cycloaddition forming spiro-pyrrolothiazoles.

## Quantitative Data: Solvent Dielectric Properties

The choice of solvent dictates the efficiency of microwave energy transfer. Use the table below to select the appropriate solvent based on its loss tangent (

), which represents its ability to convert electromagnetic energy into heat.

Solvent	Loss Tangent ( )	Heating Efficiency	Typical Yield (%)	Troubleshooting Note
Methanol	0.659	High	90–98%	Optimal for 1,3-dipolar cycloadditions; rapid heating [1].
Ethanol	0.941	Very High	85–90%	Excellent alternative, though chalcone solubility may vary.
Acetic Acid	0.174	Medium	75–85%	Alters reaction pathways (e.g., yields 6-ones from enamines) [2].
Toluene	0.040	Low	< 30%	MW transparent; reactions will stall unless ionic susceptors are added.
Acetonitrile	0.062	Low-Medium	60–70%	Requires higher power inputs; useful for moisture-sensitive pyrrolomycins [3].

## References

- Natural-Product-Inspired Microwave-Assisted Synthesis of Novel Spirooxindoles as Antileishmanial Agents: Synthesis, Stereochemical Assignment, Bioevaluation, SAR, and Molecular Docking Studies Source: MDPI URL

- Silica gel and microwave-promoted synthesis of dihydropyrrolizines and tetrahydroindolizines from enaminones Source: Beilstein Journals URL
- European Journal of Medicinal Chemistry - IRIS UniPA (Total synthesis of F-series pyrrolomycins by microwave-assisted synthesis)
- To cite this document: BenchChem. [Technical Support Center: Microwave-Assisted Pyrrolothiazole Synthesis]. BenchChem, [2026]. [Online PDF]. Available at: [\[https://www.benchchem.com/product/b14748808/docs#technical-support-center-microwave-assisted-pyrrolothiazole-synthesis\]](https://www.benchchem.com/product/b14748808/docs#technical-support-center-microwave-assisted-pyrrolothiazole-synthesis)

---

### Disclaimer & Data Validity:

The information provided in this document is for Research Use Only (RUO) and is strictly not intended for diagnostic or therapeutic procedures. While BenchChem strives to provide accurate protocols, we make no warranties, express or implied, regarding the fitness of this product for every specific experimental setup.

**Technical Support:** The protocols provided are for reference purposes. Unsure if this reagent suits your experiment?

**Need Industrial/Bulk Grade?** [Request Custom Synthesis Quote](#)

## BenchChem

Our mission is to be the trusted global source of essential and advanced chemicals, empowering scientists and researchers to drive progress in science and industry.

### Contact

Address: 3281 E Guasti Rd  
Ontario, CA 91761, United States  
Phone: (601) 213-4426  
Email: [info@benchchem.com](mailto:info@benchchem.com)

[Contact our Ph.D. Support Team for a compatibility check](#)

