

Comparative Mass Spectrometric Profiling of (3S,5S)-Gingerdiol: Fragmentation Dynamics and Structural Differentiation

Author: BenchChem Technical Support Team. **Date:** April 2026

Compound of Interest

Compound Name: (3S,5S)-[6]-Gingerdiol

Cat. No.: B14746741

[Get Quote](#)

Executive Summary

In the metabolomic profiling of *Zingiber officinale* (ginger), the accurate discrimination of (3S,5S)-gingerdiol from its structural analogs—principally 6-gingerol and 6-shogaol—is a critical analytical challenge. While 6-gingerol is the primary pungent principle, (3S,5S)-gingerdiol represents its reduced metabolite, differing by only 2 Da in molecular weight but possessing significantly distinct fragmentation kinetics due to the reduction of the C3 ketone to a hydroxyl group.

This guide provides a technical comparison of the mass spectrometry (MS) fragmentation patterns of (3S,5S)-gingerdiol against its metabolic precursors and degradation products. It focuses on distinguishing these compounds in complex biological matrices using LC-ESI-MS/MS.

Structural Context & Chemical Identity[1][2][3][4][5] [6]

Before interpreting spectra, one must understand the structural hierarchy. The "Gingeroid" family shares a 4-hydroxy-3-methoxyphenyl (vanillyl) head group but differs in the aliphatic side chain.

Compound	Structure Type	Molecular Formula	Monoisotopic Mass (Da)	Key Functional Group
(3S,5S)-Gingerdiol	1,3-Diol		296.1988	C3-OH, C5-OH (Reduced)
6-Gingerol	-Hydroxy Ketone		294.1831	C3=O, C5-OH
6-Shogaol	-Unsaturated Ketone		276.1725	C4=C5 Double Bond



Critical Note on Stereochemistry: Mass spectrometry alone is blind to the (3S,5S) vs. (3R,5S) stereochemistry. The fragmentation patterns described below apply to the 6-gingerdiol constitution. Definitive assignment of the (3S,5S) enantiomer requires chiral chromatography (e.g., Chiralpak AD-H column) prior to MS detection.

Experimental Methodology

To replicate the data discussed, the following validated LC-MS/MS protocol is recommended. This setup minimizes in-source fragmentation (dehydration), which can cause gingerdiols to mimic shogaols.

Protocol: High-Resolution LC-MS/MS Setup

- Sample Preparation:
 - Extract rhizome powder with Methanol:Water (80:20).

- Filter (0.22 μm PTFE). Do not heat above 40°C to prevent thermal dehydration of gingerols to shogaols.
- Chromatography (UHPLC):
 - Column: C18 Reverse Phase (e.g., 2.1 x 100 mm, 1.7 μm).
 - Mobile Phase A: 0.1% Formic Acid in Water.
 - Mobile Phase B: Acetonitrile.
 - Gradient: 5% B to 95% B over 12 min.
- Mass Spectrometry (ESI Source):
 - Mode: Negative Ion Mode () is preferred for sensitivity; Positive Mode () for structural confirmation.
 - Source Temp: 350°C.
 - Capillary Voltage: 2.5 kV (Negative), 3.5 kV (Positive).

Comparative Fragmentation Analysis

The differentiation of (3S,5S)-gingerdiol relies on detecting the stability of the diol moiety versus the lability of the

-hydroxy ketone in gingerol.

The "Vanillyl Anchor" (Commonality)

All three compounds (Gingerdiol, Gingerol, Shogaol) share the vanillyl head group. Upon Collision-Induced Dissociation (CID), they all yield a characteristic product ion at

137 (positive mode, vanillyl cation) or

136/135 (negative mode).

- Diagnostic Value: confirms the class (Gingeroid) but does not distinguish the specific analog.

Fragmentation Logic: Gingerdiol vs. Gingerol[8]

The table below contrasts the fragmentation pathways in Negative ESI Mode, which provides the cleanest structural data.

Feature	(3S,5S)-Gingerdiol	6-Gingerol	Mechanism of Difference
Precursor Ion ()	295	293	2 Da mass shift (Reduction).
Primary Cleavage	Benzylic Cleavage	Retro-Aldol Cleavage	Gingerol's ketone facilitates C4-C5 bond breaking.
Key Neutral Loss	Loss of Water (18 Da)	Loss of Neutral Aldehyde (194 Da)	Gingerdiol lacks the ketone for retro-aldol.
Diagnostic Fragment	277 ()	99 (Alkyl tail)	Gingerol splits into head (193) and tail (99).

Mechanistic Deep Dive

Pathway A: 6-Gingerol (Retro-Aldol Dominance)

Because 6-gingerol is a

-hydroxy ketone, it undergoes a thermally or collisionally induced Retro-Aldol cleavage at the C4-C5 bond.

- Transition:

293

193 (Zingerone-like enolate) + Hexanal (

).

- Observation: The

193 peak is often the base peak for gingerols.

Pathway B: (3S,5S)-Gingerdiol (Dehydration Dominance)

Gingerdiol lacks the C3 ketone required for the retro-aldol mechanism. Instead, the 1,3-diol structure is prone to sequential water losses.

- Transition:

295

277 (Loss of

)

259 (Loss of 2nd

).

- Observation: The absence of the strong

193 fragment (relative to the water loss peaks) is the primary fingerprint of gingerdiol.

Visualization of Fragmentation Pathways[9][10]

The following diagram illustrates the divergent fragmentation pathways that allow for the discrimination of these isobaric-like species.

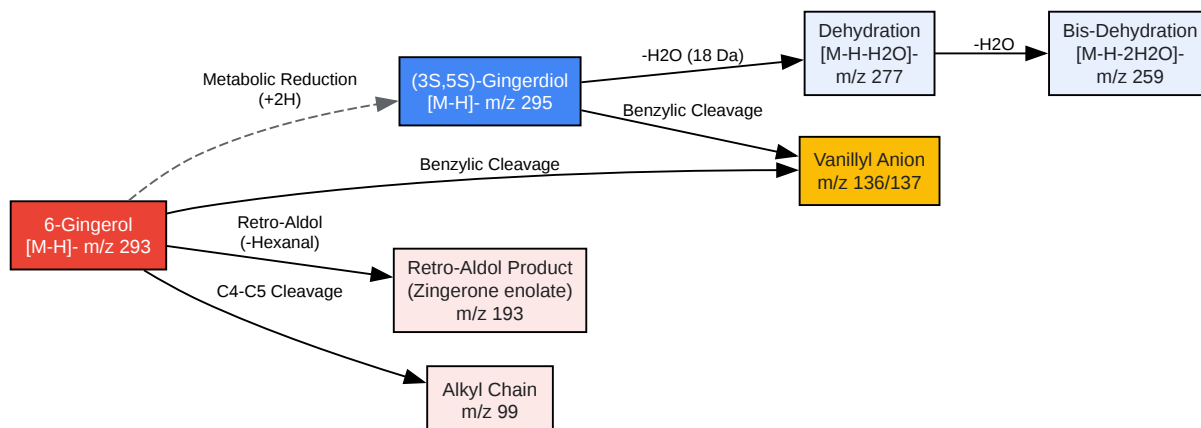

[Click to download full resolution via product page](#)

Figure 1: Divergent fragmentation pathways of Gingerdiol (Dehydration) vs. Gingerol (Retro-Aldol) in Negative ESI MS/MS.

Differentiation Protocol (Decision Tree)

When analyzing a "Ginger Extract" unknown peak, use this logical flow to assign identity.

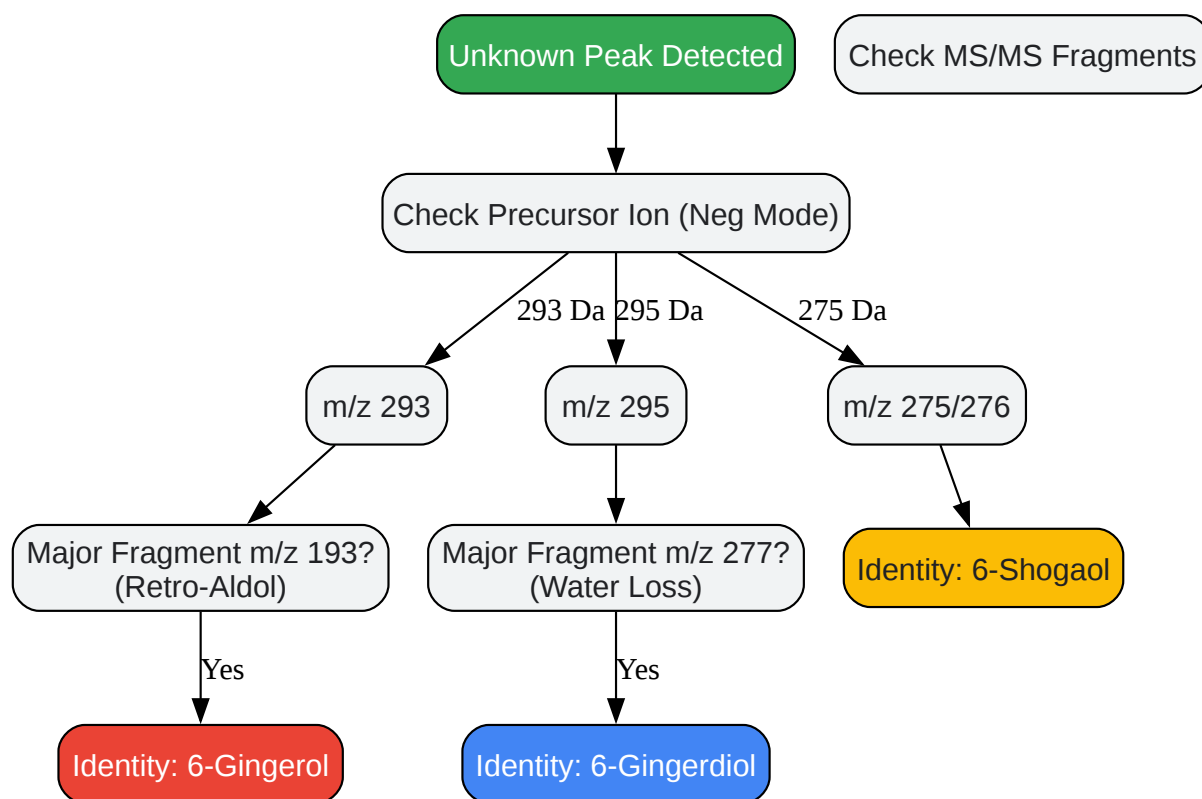

[Click to download full resolution via product page](#)

Figure 2: Logical decision tree for assigning Gingeroid identity based on precursor mass and fragmentation behavior.

Expert Insights & Pitfalls

The "In-Source" Dehydration Trap

One of the most common errors in ginger analysis is misidentifying 6-gingerol as 6-shogaol.

- The Issue: High desolvation temperatures (>400°C) or high cone voltages can force 6-gingerol (

294) to lose water before entering the quadrupole. It then appears at

276, mimicking shogaol.

- The Gingerdiol Variant: Similarly, (3S,5S)-gingerdiol (296) can dehydrate in-source to mimic a gingerol-like mass (278).
- Solution: Always monitor the "Sodium Adduct" in positive mode (). Sodium adducts are more stable and less prone to in-source dehydration than protonated ions, providing a true molecular weight check.

Quantification Challenges

While 6-gingerol has abundant commercial standards, (3S,5S)-gingerdiol standards are often expensive or require custom synthesis.

- Relative Quantification: In the absence of a specific gingerdiol standard, researchers often use the 6-gingerol calibration curve. Be aware that the Response Factor differs. Gingerdiol (more polar, two -OH groups) typically ionizes slightly better in Negative ESI than gingerol, potentially leading to overestimation if a gingerol curve is used without correction.

References

- National Institutes of Health (NIH) - PubChem.Gingerdiol Compound Summary. Retrieved from PubChem.[1] [\[Link\]](#)
- Tao, Y., Li, W., & van Breemen, R. B. (2009).Identification and Quantification of Gingerols and Related Compounds in Ginger Dietary Supplements Using High Performance Liquid Chromatography-Tandem Mass Spectrometry. Journal of Agricultural and Food Chemistry. [\[Link\]](#)
- Jiang, H., et al.Characterization of gingerol-related compounds in ginger rhizome by high-performance liquid chromatography/electrospray ionization mass spectrometry. Rapid Communications in Mass Spectrometry. [\[Link\]](#)
- Li, M., et al. (2021).Fragmentation Pathway of Gingerol Using Electrospray Ionization with Quadrupole Time-of-Flight Mass Spectrometry. Journal of Chinese Mass Spectrometry Society. [\[Link\]](#)

Need Custom Synthesis?

BenchChem offers custom synthesis for rare earth carbides and specific isotopic labeling.

Email: info@benchchem.com or [Request Quote Online](#).

Sources

- 1. Gingerdiol | C₁₇H₂₈O₄ | CID 11369949 - PubChem [pubchem.ncbi.nlm.nih.gov]
- To cite this document: BenchChem. [Comparative Mass Spectrometric Profiling of (3S,5S)-Gingerdiol: Fragmentation Dynamics and Structural Differentiation]. BenchChem, [2026]. [Online PDF]. Available at: [<https://www.benchchem.com/product/b14746741/docs#comparative-mass-spectrometric-profiling-of-3s-5s-gingerdiol-fragmentation-dynamics-and-structural-differentiation>]

Disclaimer & Data Validity:

The information provided in this document is for Research Use Only (RUO) and is strictly not intended for diagnostic or therapeutic procedures. While BenchChem strives to provide accurate protocols, we make no warranties, express or implied, regarding the fitness of this product for every specific experimental setup.

Technical Support: The protocols provided are for reference purposes. Unsure if this reagent suits your experiment?

Need Industrial/Bulk Grade? [Request Custom Synthesis Quote](#)

BenchChem

Our mission is to be the trusted global source of essential and advanced chemicals, empowering scientists and researchers to drive progress in science and industry.

Contact

Address: 3281 E Guasti Rd
Ontario, CA 91761, United States
Phone: (601) 213-4426
Email: info@benchchem.com

Contact our Ph.D. Support Team for a compatibility check