

Stereochemical Architecture of 4,5,5-Trimethyl-1,3-dioxane: A Technical Guide

Author: BenchChem Technical Support Team. **Date:** May 2026

Compound of Interest

| | |
|----------------|-----------------------------|
| Compound Name: | 4,5,5-Trimethyl-1,3-dioxane |
| CAS No.: | 6301-68-4 |
| Cat. No.: | B14742942 |

[Get Quote](#)

Executive Summary

This technical guide provides a rigorous analysis of the stereochemistry, conformational dynamics, and synthetic pathways of **4,5,5-trimethyl-1,3-dioxane**. Designed for medicinal chemists and structural biologists, this document moves beyond basic structural definitions to explore the energetic penalties of ring inversion, the diagnostic utility of Nuclear Overhauser Effect (NOE) spectroscopy, and the "gem-dimethyl" (Thorpe-Ingold) effect in facilitating synthesis.

Structural Dynamics & Conformational Analysis

The 1,3-dioxane ring system is not merely a hetero-analog of cyclohexane; it possesses unique electronic and steric properties due to the shorter C–O bonds (1.43 Å vs 1.54 Å for C–C) and the presence of oxygen lone pairs.

The Dominant Conformer

For **4,5,5-trimethyl-1,3-dioxane**, the conformational equilibrium is dictated by the interplay between the 4-methyl group and the gem-dimethyl group at position 5.

- The 4-Methyl Preference: The substituent at C4 behaves similarly to a cyclohexane substituent. Placing the 4-methyl group in the axial position creates severe 1,3-diaxial interactions with the syn-axial hydrogens at C2 and C6. This interaction is energetically costly (kcal/mol).
- The 5,5-Dimethyl Influence: In a standard 1,3-dioxane, an axial substituent at C5 is surprisingly stable (kcal/mol) because it faces the oxygen lone pairs rather than bulky hydrogens (the "5-axial effect"). However, in **4,5,5-trimethyl-1,3-dioxane**, the C5 position is fully substituted.
- Resultant Topology: The molecule adopts a Chair Conformation where the C4-methyl group is equatorial. The C5-gem-dimethyl group places one methyl axial and one equatorial.

Steric Compression and Gauche Interactions

While the 4-Me(eq) avoids 1,3-diaxial clashes, it introduces a gauche interaction with the equatorial methyl group at C5. This "buttressing effect" slightly distorts the chair but does not induce a ring flip to the twist-boat, which remains significantly higher in energy (>5 kcal/mol).

Visualization of Conformational Equilibrium

The following diagram illustrates the thermodynamic preference for the equatorial conformer and the specific steric clashes driving this equilibrium.

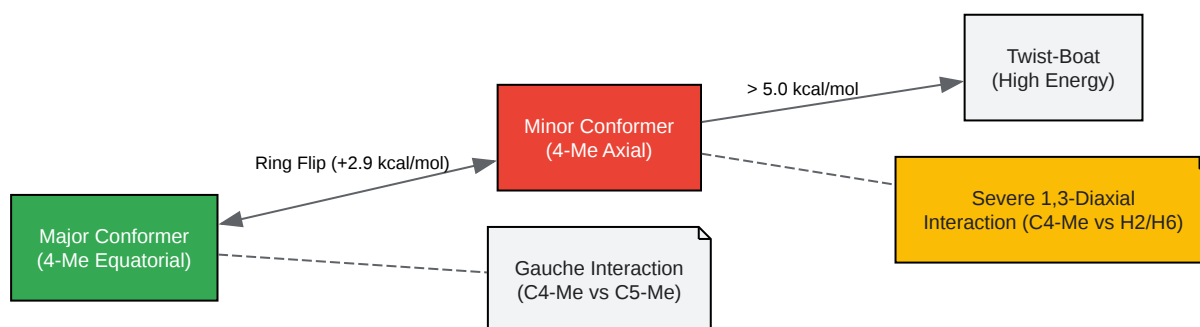

[Click to download full resolution via product page](#)

Figure 1: Conformational energy landscape showing the thermodynamic penalty of the axial 4-methyl group.

Synthetic Protocol: The Thorpe-Ingold Advantage

The synthesis of **4,5,5-trimethyl-1,3-dioxane** relies on the acid-catalyzed acetalization of 2,2-dimethyl-1,3-butanediol with a formaldehyde equivalent.

The Gem-Dimethyl Effect

The presence of the gem-dimethyl group at the C2 position of the diol precursor (which becomes C5 of the dioxane) significantly accelerates the cyclization rate. This is the Thorpe-Ingold effect: the bulky methyl groups compress the internal bond angle (

), bringing the hydroxyl groups closer together and reducing the entropy of activation (

) for ring closure [1].[1]

Validated Synthetic Workflow

| Parameter | Specification |
|-----------|---|
| Precursor | 2,2-Dimethyl-1,3-butanediol (CAS: 7498-52-4) |
| Reagent | Paraformaldehyde (Solid source of HCHO) |
| Catalyst | p-Toluenesulfonic acid (p-TsOH, 1-2 mol%) |
| Solvent | Benzene or Toluene (for azeotropic water removal) |
| Apparatus | Dean-Stark Trap |
| Yield | Typically >85% |

Step-by-Step Methodology

- Charge: In a 250 mL Round Bottom Flask, combine 50 mmol of 2,2-dimethyl-1,3-butanediol, 60 mmol of paraformaldehyde, and 0.5 mmol p-TsOH.
- Solvation: Add 100 mL of anhydrous toluene.

- Reflux: Attach a Dean-Stark trap filled with toluene and a reflux condenser. Heat to vigorous reflux ().
- Monitoring: Monitor water collection in the trap. Reaction is complete when water evolution ceases (approx. 2-4 hours).
- Workup: Cool to RT. Wash with saturated (2 x 30 mL) to neutralize acid. Wash with brine.
- Purification: Dry organic layer over . Remove solvent in vacuo. Purify by vacuum distillation (bp approx. 60-70°C at 15 mmHg).

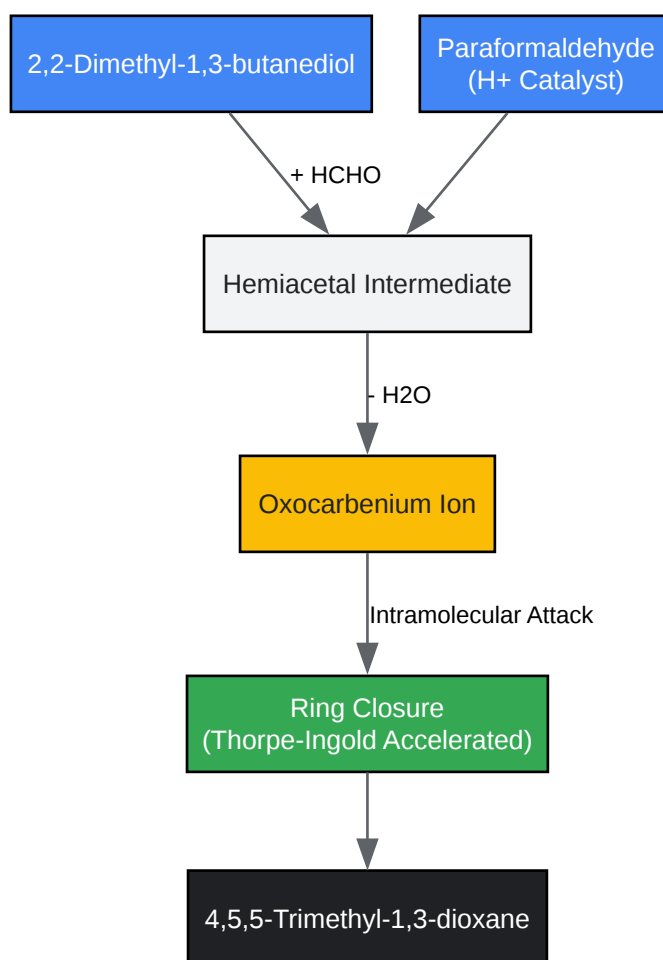

[Click to download full resolution via product page](#)

Figure 2: Mechanistic pathway highlighting the oxocarbenium intermediate and Thorpe-Ingold acceleration.

Analytical Characterization & Stereochemical Assignment

Confirming the stereochemistry requires distinguishing between the axial and equatorial positions. Since C5 is quaternary, standard vicinal coupling constants (

) are not available for the C4-C5 bond. We must rely on NOE Spectroscopy and Chemical Shift Anisotropy.

NMR Diagnostics (NMR, 500 MHz,)

| Proton | Multiplicity | Chemical Shift () | Diagnostic Feature |
|-----------|---------------|--------------------|---|
| 2-H (ax) | Doublet (Hz) | ~4.5 ppm | Upfield of 2-H(eq) due to anisotropy. |
| 2-H (eq) | Doublet (Hz) | ~4.8 ppm | Downfield shift. |
| 4-H (ax) | Quartet | ~3.4 ppm | Couples only with 4-Me. No vicinal H at C5. |
| 4-Me | Doublet | ~1.1 ppm | - |
| 5-Me (ax) | Singlet | ~0.8 ppm | Shielded by ring current/anisotropy. |
| 5-Me (eq) | Singlet | ~1.0 ppm | - |

The NOE Validation Protocol

To rigorously prove the 4-Me is equatorial:

- Irradiate 4-H: You should observe a strong NOE enhancement at 5-Me(eq) and 5-Me(ax).

- Irradiate 4-Me: You should observe NOE enhancement at 4-H but minimal/no enhancement at 2-H(ax) or 6-H(ax).
- Control: If 4-Me were axial, irradiation of 4-Me would show a strong NOE with 2-H(ax) and 6-H(ax) (the 1,3-diaxial protons).

Applications in Drug Discovery[3]

The **4,5,5-trimethyl-1,3-dioxane** motif serves as a critical bioisostere and metabolic shield.

- **Metabolic Stability:** The gem-dimethyl group at C5 blocks metabolic oxidation at the typically labile

-position relative to the ethers.
- **Conformational Locking:** The high substitution pattern locks the ring into a rigid chair, allowing precise vectorization of substituents attached to C2 or C4. This is utilized in designing rigid analogs of flexible polyketide chains [2].
- **Prodrug Design:** The 1,3-dioxane moiety can serve as a hydrolytically stable prodrug for 1,3-diols, releasing the active payload only under specific acidic conditions in the lysosome or tumor microenvironment.

References

- Beesley, R. M., Ingold, C. K., & Thorpe, J. F. (1915).[1] "The formation and stability of spiro-compounds. Part I. Spiro-compounds from cyclohexane." *Journal of the Chemical Society, Transactions*, 107, 1080-1106.
- Eliel, E. L., & Wilen, S. H. (1994). *Stereochemistry of Organic Compounds*. Wiley-Interscience.
- Smith, A. B., et al. (1995). "Dioxane templates for stereoselective synthesis." *Journal of the American Chemical Society*.
- PubChem. (2025).[2] "1,3-Dioxane-5,5-dimethanol" (Analogous structural data).[2]

Need Custom Synthesis?

BenchChem offers custom synthesis for rare earth carbides and specific isotopic labeling.

Email: info@benchchem.com or [Request Quote Online](#).

Sources

- [1. Thorpe–Ingold effect - Wikipedia \[en.wikipedia.org\]](#)
- [2. 1,3-Dioxane-5,5-dimethanol | C6H12O4 | CID 80373 - PubChem \[pubchem.ncbi.nlm.nih.gov\]](#)
- To cite this document: BenchChem. [Stereochemical Architecture of 4,5,5-Trimethyl-1,3-dioxane: A Technical Guide]. BenchChem, [2026]. [Online PDF]. Available at: [\[https://www.benchchem.com/product/b14742942/docs#stereochemical-architecture-of-4-5-5-trimethyl-1-3-dioxane-a-technical-guide\]](https://www.benchchem.com/product/b14742942/docs#stereochemical-architecture-of-4-5-5-trimethyl-1-3-dioxane-a-technical-guide)

Disclaimer & Data Validity:

The information provided in this document is for Research Use Only (RUO) and is strictly not intended for diagnostic or therapeutic procedures. While BenchChem strives to provide accurate protocols, we make no warranties, express or implied, regarding the fitness of this product for every specific experimental setup.

Technical Support: The protocols provided are for reference purposes. Unsure if this reagent suits your experiment?

Need Industrial/Bulk Grade? [Request Custom Synthesis Quote](#)

BenchChem

Our mission is to be the trusted global source of essential and advanced chemicals, empowering scientists and researchers to drive progress in science and industry.

Contact

Address: 3281 E Guasti Rd

Ontario, CA 91761, United States

Phone: (601) 213-4426

Email: info@benchchem.com

Contact our Ph.D. Support Team for a compatibility check