

# Spiro[5.7]tridecan-13-one CAS number and supplier database

**Author:** BenchChem Technical Support Team. **Date:** April 2026

## Compound of Interest

Compound Name: Spiro[5.7]tridecan-13-one

CAS No.: 4728-92-1

Cat. No.: B14739746

[Get Quote](#)

## Technical Guide: Spiro[5.7]tridecan-13-one[1][2] Part 1: Executive Summary & Chemical Identity[2]

**Spiro[5.7]tridecan-13-one** is a bicyclic spiro-ketone featuring a cyclohexane ring spiro-fused to a cyclooctane ring.[1][2] In the context of medicinal chemistry, this scaffold represents a high-

building block, offering specific three-dimensional vectors that differ significantly from flat aromatic systems.[1][2]

While often referred to as **Spiro[5.7]tridecan-13-one** in legacy literature and catalogs, the preferred IUPAC numbering typically assigns the ketone to position 7 (adjacent to the spiro center).[1][2] Due to the symmetry of the unsubstituted skeleton, the 7-one and 13-one locants refer to the same chemical entity (the

-spiro ketone).[1][2]

## Core Identifiers

Parameter	Data
Chemical Name	Spiro[5.7]tridecan-13-one (or Spiro[5.7]tridecan-7-one)
CAS Number	4728-92-1
Molecular Formula	C <sub>13</sub> H <sub>22</sub> O
Molecular Weight	194.32 g/mol
SMILES	O=C1CCCCCCC12CCCCC2
InChIKey	Derivative specific; core skeleton: AAMFRVWJXKBTFE-UHFFFAOYSA-N
Structural Class	Spirocyclic Ketone; Medium-Ring Carbocycle

## Supplier Database & Availability

Direct commercial availability of the saturated ketone (CAS 4728-92-1) is limited compared to its unsaturated derivatives.<sup>[1][2]</sup> It is frequently categorized as a "make-on-demand" building block.<sup>[1][2]</sup>

- Primary Aggregators: Molbase, Echemi, and SciFinder-n.<sup>[1][2]</sup>
- Key Suppliers: Specialized catalog houses such as J&H Chemical or BOC Sciences often list this CAS, though stock verification is required.<sup>[1][2]</sup>
- Alternative Commercial Derivatives:
  - Spiro[5.7]tridec-1-ene-3-one (CAS 60033-39-8)<sup>[1]</sup>
  - Spiro[5.7]trideca-1,4-dien-3-one (CAS 41138-71-0)<sup>[1][2]</sup>
  - Note: These enones can be hydrogenated to yield the saturated parent scaffold.<sup>[1][2]</sup>

## Part 2: Synthesis & Manufacturing Protocols

For research applications requiring gram-scale quantities, de novo synthesis is often more reliable than sourcing from rare chemical inventories.<sup>[1][2]</sup> Two primary routes are established: Geminal Dialkylation (Route A) and Ring Expansion (Route B).<sup>[1][2]</sup>

## Route A: Geminal Dialkylation (Direct Approach)

This method constructs the spiro junction by alkylating a cyclic ketone with a dihaloalkane.<sup>[1]</sup>

Mechanism: Double nucleophilic substitution (

-alkylation).<sup>[1][2]</sup> Precursors: Cyclooctanone + 1,5-Dibromopentane.<sup>[1][2]</sup>

- Reagents: Cyclooctanone (1.0 eq), 1,5-Dibromopentane (1.1 eq), Potassium tert-butoxide (-BuOK, 2.2 eq).
- Solvent: Anhydrous THF or Benzene/Toluene.
- Protocol:
  - Dissolve cyclooctanone in anhydrous THF under atmosphere.
  - Add -BuOK slowly at 0°C to generate the enolate.<sup>[1]</sup>
  - Add 1,5-dibromopentane dropwise.<sup>[1][2]</sup>
  - Reflux for 12–24 hours.<sup>[1]</sup> The first alkylation occurs at the -position; the second alkylation closes the ring at the same carbon (geminal) due to the thermodynamic preference for spiro-cyclization over fused-ring formation in these conditions.<sup>[1]</sup>
  - Purification: Silica gel chromatography (Hexanes/EtOAc).<sup>[1][2]</sup>
  - Yield: Typically 40–60%.<sup>[1][2]</sup>

## Route B: Tiffeneau-Demjanov Ring Expansion

This route is preferred if the 6-membered spiro-ketone (Spiro[5.6]dodecan-7-one) is available. [1][2] It expands the 7-membered ring to an 8-membered ring, inserting a methylene group adjacent to the carbonyl. [1][2]

Protocol:

- Starting Material: Spiro[5.6]dodecan-7-one (CAS 4728-90-9). [1][2]
- Step 1: React with Diazomethane ( ) or Trimethylsilyldiazomethane ( ) in the presence of a Lewis acid (e.g., ). [1][2]
- Step 2: The methylene group inserts preferentially on the more substituted side (or statistically if symmetric), expanding the ring to the **Spiro[5.7]tridecan-13-one** system. [1][2]

## Synthesis Workflow Diagram

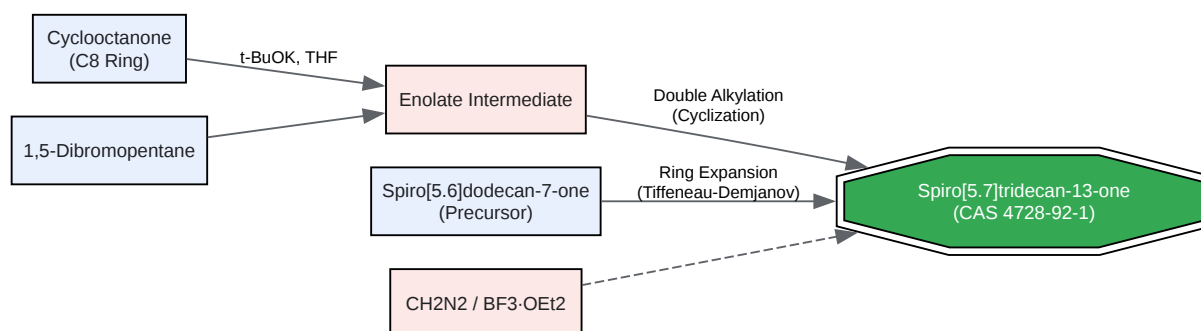

[Click to download full resolution via product page](#)

Caption: Two primary synthetic pathways for accessing the **Spiro[5.7]tridecan-13-one** scaffold. [1][2]

## Part 3: Analytical Profile & Drug Discovery

### Applications

### Analytical Expectations

When validating the synthesized compound, the following spectral characteristics confirm the spiro[5.7] structure:

- $^1\text{H}$  NMR ( $\text{CDCl}_3$ ):
  - -Protons: Multiplet at 2.4–2.6 ppm (2H, adjacent to carbonyl in the 8-ring).[1]
  - Spiro-Adjacent: Distinct shielding patterns for protons on the cyclohexane ring due to the orthogonal ring current effects, though less pronounced in saturated systems.[1][2]
  - Bulk Methylenes: Broad multiplets in the 1.2–1.8 ppm range.[1][2]
- $^{13}\text{C}$  NMR:
  - Carbonyl (C=O): Characteristic peak at ~215–218 ppm (typical for medium-ring ketones).[1][2]
  - Quaternary Spiro Carbon: A singlet in the aliphatic region, typically 40–50 ppm, which does not phase in DEPT-135 experiments.[2]

### Strategic Value in Drug Design

The Spiro[5.7]tridecane scaffold is utilized to improve the physicochemical properties of drug candidates ("Escape from Flatland"):

- Novel IP Space: Less crowded patent landscape compared to spiro[3.3] or spiro[5.5] systems.[1][2]

- Conformational Restriction: The spiro center locks the orientation of the two rings, providing a rigid vector for substituent display that can enhance selectivity for protein binding pockets. [1][2]
- Metabolic Stability: The quaternary spiro carbon blocks metabolic oxidation at that position, potentially increasing half-life compared to linear alkyl chains.[1][2]

## References

- PubChem Compound Summary.Spiro[5.7]tridecane (CID 21501371).[1][2] National Center for Biotechnology Information.[1] Available at: [\[Link\]](#)[1]
- Krapcho, A. P., et al.Ionic reactions in the spiran series.[1][2] III. Solvolysis of medium-sized-ring spiro compounds. Journal of Organic Chemistry, 1968.[1] (Establishes CAS 4728-92-1 and synthesis via ring expansion).[1][2] Available at: [\[Link\]](#)[1]
- Molbase Chemical Database.**Spiro[5.7]tridecan-13-one** (CAS 4728-92-1).[1][2] Available at: [\[Link\]](#)[1][2]
- Noyori, R., et al.  
  
-Dibromoketones and Enamines.[2][3] Organic Syntheses, Coll.[1][2][3] Vol. 6, p.436.[1][3] (Describes general principles of spiroannulation). Available at: [\[Link\]](#)[1]

### Need Custom Synthesis?

BenchChem offers custom synthesis for rare earth carbides and specific isotopic labeling.

Email: [info@benchchem.com](mailto:info@benchchem.com) or [Request Quote Online](#).

## Sources

- 1. 7-Tridecanone | C<sub>13</sub>H<sub>26</sub>O | CID 10015 - PubChem [\[pubchem.ncbi.nlm.nih.gov\]](https://pubchem.ncbi.nlm.nih.gov)
- 2. 1,5-Dibromopentane-1,1,5,5-d<sub>4</sub> | C<sub>5</sub>H<sub>10</sub>Br<sub>2</sub> | CID 12231137 - PubChem [\[pubchem.ncbi.nlm.nih.gov\]](https://pubchem.ncbi.nlm.nih.gov)
- 3. Organic Syntheses Procedure [\[orgsyn.org\]](https://orgsyn.org)

- To cite this document: BenchChem. [Spiro[5.7]tridecan-13-one CAS number and supplier database]. BenchChem, [2026]. [Online PDF]. Available at: [<https://www.benchchem.com/product/b14739746/docs#spiro-5-7-tridecan-13-one-cas-number-and-supplier-database>]

---

### Disclaimer & Data Validity:

The information provided in this document is for Research Use Only (RUO) and is strictly not intended for diagnostic or therapeutic procedures. While BenchChem strives to provide accurate protocols, we make no warranties, express or implied, regarding the fitness of this product for every specific experimental setup.

**Technical Support:** The protocols provided are for reference purposes. Unsure if this reagent suits your experiment?

**Need Industrial/Bulk Grade?** [Request Custom Synthesis Quote](#)

## BenchChem

Our mission is to be the trusted global source of essential and advanced chemicals, empowering scientists and researchers to drive progress in science and industry.

### Contact

Address: 3281 E Guasti Rd  
Ontario, CA 91761, United States  
Phone: (601) 213-4426  
Email: [info@benchchem.com](mailto:info@benchchem.com)

[Contact our Ph.D. Support Team for a compatibility check](#)