

GC-MS fragmentation patterns of cyclohexyl phenyl ethers

Author: BenchChem Technical Support Team. **Date:** May 2026

Compound of Interest

Compound Name: 1-Cyclohexyl-2-ethoxybenzene

CAS No.: 1889-30-1

Cat. No.: B14739453

[Get Quote](#)

GC-MS Fragmentation Dynamics: Cyclohexyl Phenyl Ethers

Executive Summary & Scientific Rationale

Cyclohexyl phenyl ethers (CPEs) represent a unique intersection of aromatic stability and alicyclic reactivity. Unlike simple alkyl phenyl ethers, CPEs possess a constrained cyclic geometry that favors specific hydrogen transfer mechanisms under Electron Ionization (EI).

For the drug development professional, distinguishing CPEs from their linear isomers (e.g., hexyl phenyl ethers) or aliphatic analogues is critical during impurity profiling and metabolite identification. This guide establishes a self-validating identification protocol based on the Phenol Radical Cation (m/z 94) dominance and specific ring-contraction markers.

Standardized Experimental Protocol

To ensure reproducible fragmentation patterns, the following GC-MS conditions are recommended. These parameters minimize thermal degradation prior to ionization while

maximizing sensitivity for the molecular ion.

Methodology: High-Fidelity EI-MS Acquisition

Parameter	Setting	Rationale
Column	5% Phenyl-methylpolysiloxane (e.g., HP-5ms, DB-5)	Non-polar stationary phase prevents peak tailing of the ether oxygen.
Dimensions	30 m 0.25 mm 0.25 μ m	Optimal resolution for separating isomeric ethers.
Carrier Gas	Helium @ 1.0 mL/min (Constant Flow)	Maintains consistent ionization timing.
Inlet Temp	250 °C	Sufficient for volatilization without inducing thermal pyrolysis.[1]
Source Temp	230 °C	Prevents condensation; higher temps (>280°C) may alter fragmentation ratios.
Ionization	EI (70 eV)	Standard energy for library matching (NIST/Wiley).
Scan Range	m/z 40 – 350	Captures low-mass ring fragments and the molecular ion.

Mechanistic Fragmentation Analysis

The fragmentation of cyclohexyl phenyl ether is governed by the competition between the stability of the aromatic ring and the lability of the alicyclic protons.

The Dominant Pathway: -Hydrogen Transfer (m/z 94)

The base peak in the mass spectrum of CPE is almost invariably m/z 94 (

). This is not a simple bond cleavage but a rearrangement driven by the "Hydrogen Affinity" of the ether oxygen.

- Ionization: An electron is removed from the lone pair of the ether oxygen, forming the molecular ion (m/z 176).
- Conformational Lock: The cyclohexyl ring adopts a chair conformation where an axial -hydrogen is spatially accessible to the radical oxygen.
- McLafferty-Type Rearrangement: A 6-membered transition state facilitates the transfer of the -hydrogen to the oxygen.
- Elimination: The C-O bond cleaves, releasing a neutral cyclohexene molecule (82 Da) and leaving the stable phenol radical cation (m/z 94).

Stevenson's Rule Application: According to Stevenson's Rule, the positive charge remains on the fragment with the lower Ionization Energy (IE).

- Phenol IE: ~ 8.5 eV[2]
- Cyclohexene IE: ~ 8.9 eV[2]
- Result: The charge is strongly retained by the phenol fragment (m/z 94), making it the base peak.

Secondary Pathways: Ring Disintegration

While the aromatic moiety remains intact, the cyclohexyl ring (if the charge resides there) undergoes characteristic disintegration:

- m/z 55 (): Formed from the cyclohexyl cation via retro-Diels-Alder fragmentation (loss of ethene).
- m/z 77 ()

): Phenyl cation, formed by the direct cleavage of the C-O bond (less favorable than the rearrangement).

Visualization of Fragmentation Pathways

The following diagram illustrates the mechanistic causality described above.

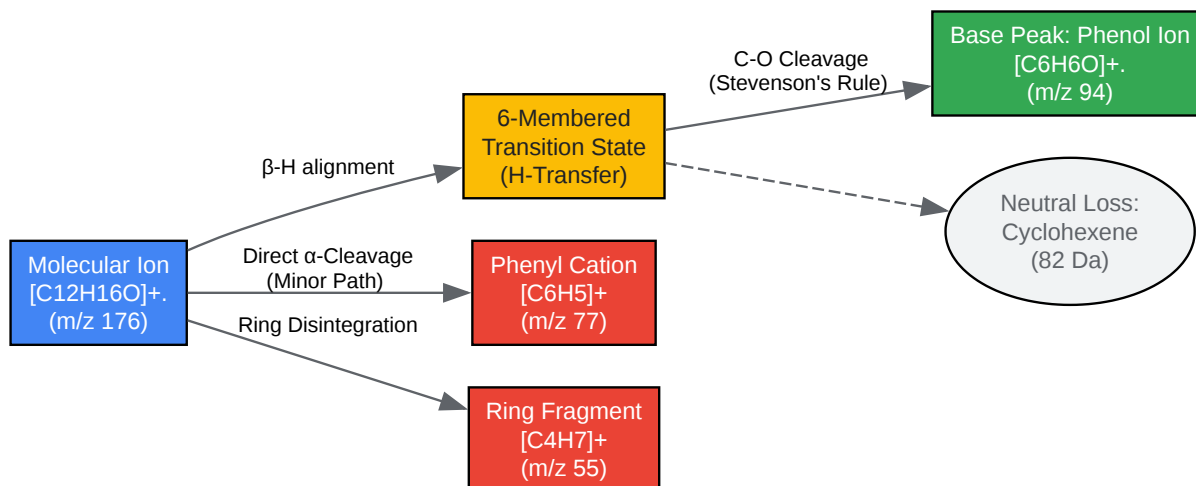

[Click to download full resolution via product page](#)

Figure 1: Mechanistic pathway showing the dominance of the phenol radical cation formation via

-hydrogen transfer.

Comparative Analysis: CPE vs. Alternatives

To validate the identity of a CPE, one must compare it against its structural isomers and analogues.

Table 1: Diagnostic Ion Comparison

Feature	Cyclohexyl Phenyl Ether (CPE)	n-Hexyl Phenyl Ether (Linear Isomer)	Dicyclohexyl Ether (Aliphatic Analogue)
Molecular Ion ()	m/z 176 (Distinct)	m/z 178 (if saturated) / 176	m/z 182 (Weak/Absent)
Base Peak	m/z 94 (Phenol Radical)	m/z 94 (Phenol Radical)	m/z 55 or 83 (Cyclohexyl ions)
Mechanism	Loss of Cyclohexene (82 Da)	Loss of Hexene (84 Da)	-Cleavage / Inductive cleavage
Key Distinguisher	m/z 55 is prominent; m/z 83 is weak.	Series of alkyl losses (m/z 29, 43, 57).	No m/z 77 or 94. Oxygen retains charge on alkyl chain.
Aromatic Stability	High (Ring stabilizes charge)	High	Low (Easily fragments)

Critical Differentiation Strategy

- CPE vs. Linear Alkyl Phenyl Ethers: Both produce the m/z 94 base peak. However, CPEs lack the characteristic alkyl chain series () seen in linear ethers (m/z 43, 57, 71). Instead, CPEs show discrete ring fragments (m/z 55, 41).
- CPE vs. Aliphatic Ethers: Aliphatic ethers (e.g., dicyclohexyl ether) do not form the m/z 94 peak. Their spectra are dominated by oxonium ions () or hydrocarbon fragments. The presence of m/z 94 is diagnostic for the phenoxy group.

Self-Validating Workflow for Identification

Use this logic flow to confirm the presence of Cyclohexyl Phenyl Ether in an unknown sample.

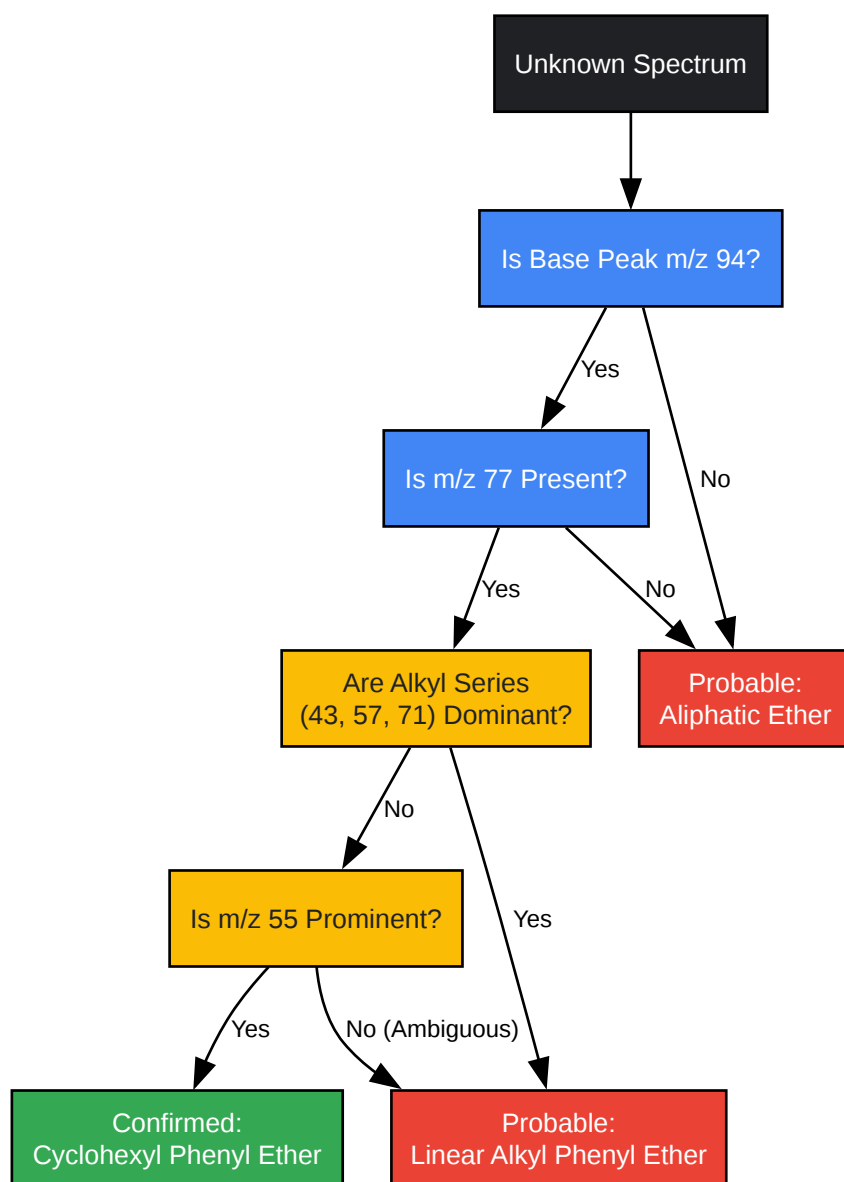

[Click to download full resolution via product page](#)

Figure 2: Logic gate for distinguishing CPE from common ether contaminants.

References

- NIST Mass Spectrometry Data Center. Cyclohexyl phenyl ether Mass Spectrum. [3] National Institute of Standards and Technology. [Link](#)
- McLafferty, F. W., & Tureček, F. (1993). Interpretation of Mass Spectra. [1][2][4][5][6][7][8][9][10][11] University Science Books. (Standard text for rearrangement mechanisms).

- PubChem.Benzene, (cyclohexyloxy)- Compound Summary.[3] National Library of Medicine. [Link](#)
- BenchChem.Mass Spectrometry Fragmentation of 2-(Hydroxy-phenyl-methyl)-cyclohexanone. (Reference for cyclohexyl ring fragmentation dynamics). [Link](#)

Need Custom Synthesis?

BenchChem offers custom synthesis for rare earth carbides and specific isotopic labeling.

Email: info@benchchem.com or [Request Quote Online](#).

Sources

- 1. pdf.benchchem.com [pdf.benchchem.com]
- 2. massbank.eu [massbank.eu]
- 3. Benzene, (cyclohexyloxy)- | C12H16O | CID 137492 - PubChem [pubchem.ncbi.nlm.nih.gov]
- 4. knockhardy.org.uk [knockhardy.org.uk]
- 5. chem.libretexts.org [chem.libretexts.org]
- 6. m.youtube.com [m.youtube.com]
- 7. Mass spectrometric analysis of long chain alk-1-enyl ether esters and alkyl ether esters of diols - PubMed [pubmed.ncbi.nlm.nih.gov]
- 8. cires1.colorado.edu [cires1.colorado.edu]
- 9. GCMS Section 6.13 [people.whitman.edu]
- 10. researchgate.net [researchgate.net]
- 11. Claisen rearrangement of allyl phenyl ether and its sulfur and selenium analogues on electron impact - PubMed [pubmed.ncbi.nlm.nih.gov]
- To cite this document: BenchChem. [GC-MS fragmentation patterns of cyclohexyl phenyl ethers]. BenchChem, [2026]. [Online PDF]. Available at: [<https://www.benchchem.com/product/b14739453/docs#gc-ms-fragmentation-patterns-of-cyclohexyl-phenyl-ethers>]

Disclaimer & Data Validity:

The information provided in this document is for Research Use Only (RUO) and is strictly not intended for diagnostic or therapeutic procedures. While BenchChem strives to provide accurate protocols, we make no warranties, express or implied, regarding the fitness of this product for every specific experimental setup.

Technical Support: The protocols provided are for reference purposes. Unsure if this reagent suits your experiment?

Need Industrial/Bulk Grade? [Request Custom Synthesis Quote](#)

BenchChem

Our mission is to be the trusted global source of essential and advanced chemicals, empowering scientists and researchers to drive progress in science and industry.

Contact

Address: 3281 E Guasti Rd
Ontario, CA 91761, United States
Phone: (601) 213-4426
Email: info@benchchem.com

[Contact our Ph.D. Support Team for a compatibility check](#)