

Comparative study of catalysts for the synthesis of fluorinated esters

Author: BenchChem Technical Support Team. **Date:** April 2026

Compound of Interest

Compound Name: *Ethyl 2,6-difluoro-4-methylbenzoate*

CAS No.: 1337606-88-8

Cat. No.: B1473821

[Get Quote](#)

An Application Scientist's Guide to Catalysis in Fluorinated Ester Synthesis

Introduction: The Strategic Value of Fluorinated Esters

The strategic incorporation of fluorine into organic molecules has become a cornerstone of modern drug discovery and materials science. It is estimated that 20% of pharmaceuticals and 30-40% of agrochemicals contain fluorine, a testament to the profound effects this element can have on a molecule's biological and physical properties.[1] Fluorine's high electronegativity, the strength of the carbon-fluorine bond, and its relatively small size can significantly enhance metabolic stability, binding affinity, and bioavailability.[1][2] Fluorinated esters, in particular, serve as crucial building blocks for a wide array of more complex, biologically active compounds.[3][4]

However, the synthesis of these valuable molecules is not without its challenges. The choice of catalyst is paramount, directly influencing reaction efficiency, selectivity (particularly stereoselectivity), and overall process sustainability. This guide provides a comparative

analysis of four major classes of catalysts employed in the synthesis of fluorinated esters: Lewis acids, Brønsted acids, organocatalysts, and enzymes. By examining the mechanistic underpinnings, performance data, and practical considerations of each, this document aims to equip researchers, scientists, and drug development professionals with the knowledge to make informed decisions in their synthetic endeavors.

Lewis Acid Catalysis: The Workhorse for Electrophilic Activation

Lewis acid catalysis is a classical and powerful strategy, particularly for reactions like Friedel-Crafts acylation and esterification. The efficacy of a Lewis acid stems from its ability to accept an electron pair, thereby activating a substrate and rendering it more susceptible to nucleophilic attack.^[5]

Mechanism of Action: Activating the Acyl Donor

In a typical esterification or Friedel-Crafts acylation, the Lewis acid (e.g., AlCl_3 , $\text{BF}_3 \cdot \text{OEt}_2$) coordinates to a carbonyl oxygen of the acyl donor (like an acid anhydride or acyl chloride). This coordination polarizes the $\text{C}=\text{O}$ bond, dramatically increasing the electrophilicity of the carbonyl carbon and generating a highly reactive acylium ion or a strongly activated complex. This electrophile is then readily attacked by the nucleophile (an alcohol or an electron-rich aromatic ring) to form the product.^{[5][6]}

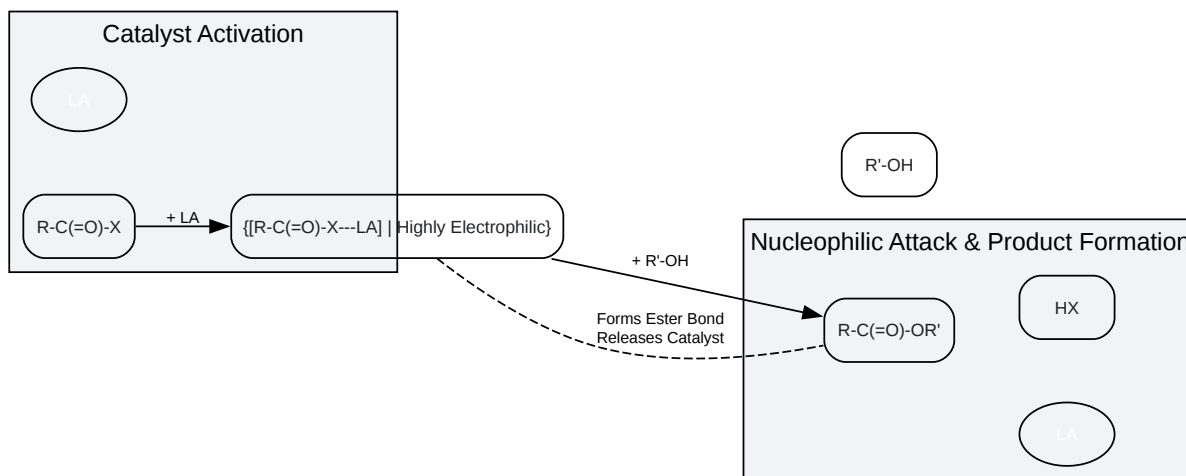

[Click to download full resolution via product page](#)

Caption: Generalized mechanism of Lewis acid-catalyzed esterification.

Performance Comparison

Lewis acids are particularly effective for synthesizing fluorinated aromatics via Friedel-Crafts acylation. The choice of catalyst represents a trade-off between reactivity, cost, and handling.

Catalyst	Substrates	Reaction	Typical Yield	Key Advantages	Key Disadvantages	Reference
AlCl ₃	1,2-Difluorobenzene + Succinic Anhydride	Friedel-Crafts Acylation	High	High reactivity, potent catalyst	Hygroscopic, requires stoichiometric amounts, generates waste	[6]
FeCl ₃	1,2-Difluorobenzene + Succinic Anhydride	Friedel-Crafts Acylation	Moderate to High	Cost-effective, less moisture-sensitive	Generally lower reactivity than AlCl ₃	[6]
BF ₃ ·OEt ₂	Benzoic Acid + Methanol	Esterification	~75% (Hypothetical)	Strong Lewis acidity, commercially available	Moisture sensitive	[5]
Hf[N(SO ₂ -n-C ₈ F ₁₇) ₂] ₄	Carboxylic Acid + Alcohol	Direct Esterification	High (e.g., 98%)	Water-stable, recyclable (fluorous phase)	Specialized catalyst, higher cost	[7]

Experimental Protocol: Synthesis of 4-(3,4-Difluorophenyl)-4-oxobutanoic Acid via Friedel-Crafts Acylation

This protocol is representative of a Lewis acid-catalyzed reaction for producing a key fluorinated intermediate.[6]

Materials:

- 1,2-Difluorobenzene
- Succinic Anhydride
- Aluminum Chloride (AlCl_3), anhydrous
- Dichloromethane (DCM), anhydrous
- Hydrochloric acid, dilute
- Ice

Procedure:

- **Reaction Setup:** In a flame-dried, three-necked flask equipped with a magnetic stirrer, dropping funnel, and nitrogen inlet, suspend anhydrous AlCl_3 (1.2 equivalents) in anhydrous DCM.
- **Reagent Addition:** Cool the suspension to 0°C using an ice bath. Add a solution of succinic anhydride (1.0 equivalent) and 1,2-difluorobenzene (1.1 equivalents) in anhydrous DCM dropwise over 30 minutes, maintaining the temperature below 5°C .
- **Reaction:** Allow the mixture to warm to room temperature and stir for 12-16 hours. Monitor the reaction progress by Thin Layer Chromatography (TLC).
- **Work-up:** Carefully quench the reaction by slowly pouring the mixture into a beaker containing crushed ice and dilute HCl.
- **Extraction:** Separate the organic layer. Extract the aqueous layer twice with DCM.
- **Purification:** Combine the organic layers, wash with brine, dry over anhydrous Na_2SO_4 , and concentrate under reduced pressure. The crude product can be purified by recrystallization or column chromatography.

Brønsted Acid Catalysis: The Proton-Donation Pathway

Brønsted acids catalyze esterification by donating a proton to the carbonyl oxygen of the carboxylic acid. This protonation enhances the electrophilicity of the carbonyl carbon, facilitating attack by the alcohol nucleophile.[8][9] This method is fundamental in organic chemistry and offers a metal-free alternative to Lewis acid catalysis.

Mechanism of Action: Enhancing Carbonyl Electrophilicity

The catalytic cycle begins with the protonation of the carboxylic acid by a Brønsted acid (e.g., H_2SO_4 , CSA), forming a resonance-stabilized cation.[9] This activation lowers the energy barrier for the subsequent nucleophilic attack by an alcohol, leading to a tetrahedral intermediate. A series of proton transfers follows, culminating in the elimination of water and regeneration of the acid catalyst.[8]

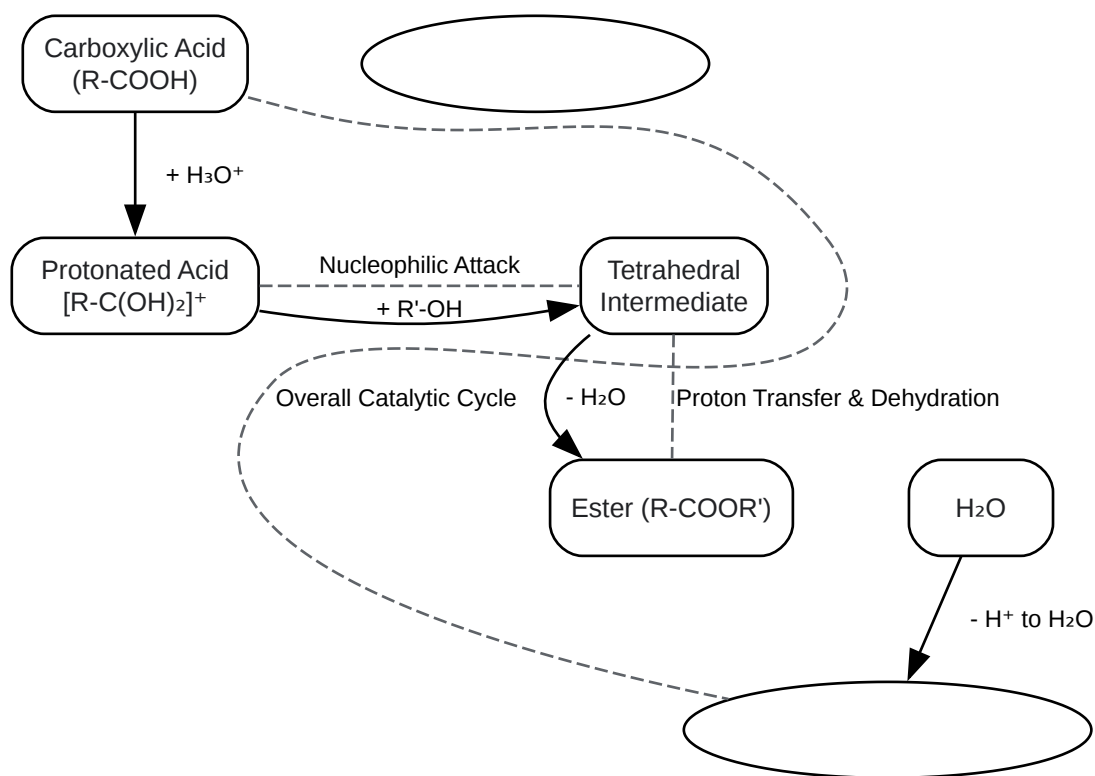

[Click to download full resolution via product page](#)

Caption: Simplified mechanism for Brønsted acid-catalyzed esterification.

Performance and Applications

While direct comparative data for Brønsted acids in fluorinated ester synthesis is less consolidated than for other catalysts, the principles are widely applied. They are particularly useful in reactions where a metal-free environment is desired. For example, camphorsulfonic acid (CSA) has been used to catalyze the synthesis of sulfinimide esters from sulfenamides using an electrophilic fluorinating reagent, demonstrating its utility in complex transformations involving fluorine.[10] The efficiency can be modulated by the acid's strength and the reaction conditions.[11][12]

Catalyst	Substrates	Reaction Type	Yield	Key Advantages	Key Disadvantages	Reference
CSA	Sulfenamides, Alcohols, Selectfluor	Fluorination & Substitution	Up to 97%	Metal-free, mild conditions	Substrate-specific application	[10]
H ₂ SO ₄	Generic Carboxylic Acid + Alcohol	Fischer Esterification	Variable (equilibrium)	Inexpensive, widely available	Can cause side reactions (dehydration, charring)	[9]

Organocatalysis: The Asymmetric Advantage

Organocatalysis has emerged as a powerful tool for constructing chiral molecules, including those containing fluorine.[3] These small organic molecules, often derived from natural products like cinchona alkaloids, can create a chiral environment to direct the stereochemical outcome of a reaction, yielding products with high enantiomeric excess (ee).[1]

Mechanism of Action: Creating a Chiral Environment

In a typical reaction, a bifunctional organocatalyst, such as a cinchona alkaloid derivative, can activate both the nucleophile and the electrophile simultaneously. For instance, the tertiary amine moiety can act as a Brønsted base to deprotonate the nucleophile (e.g., an α -fluoroketoester), while the hydroxyl group can form a hydrogen bond with the electrophile (e.g.,

a nitroolefin), orienting it for a stereoselective attack.[1][13][14] This dual activation in a defined chiral space leads to the formation of a specific stereoisomer.

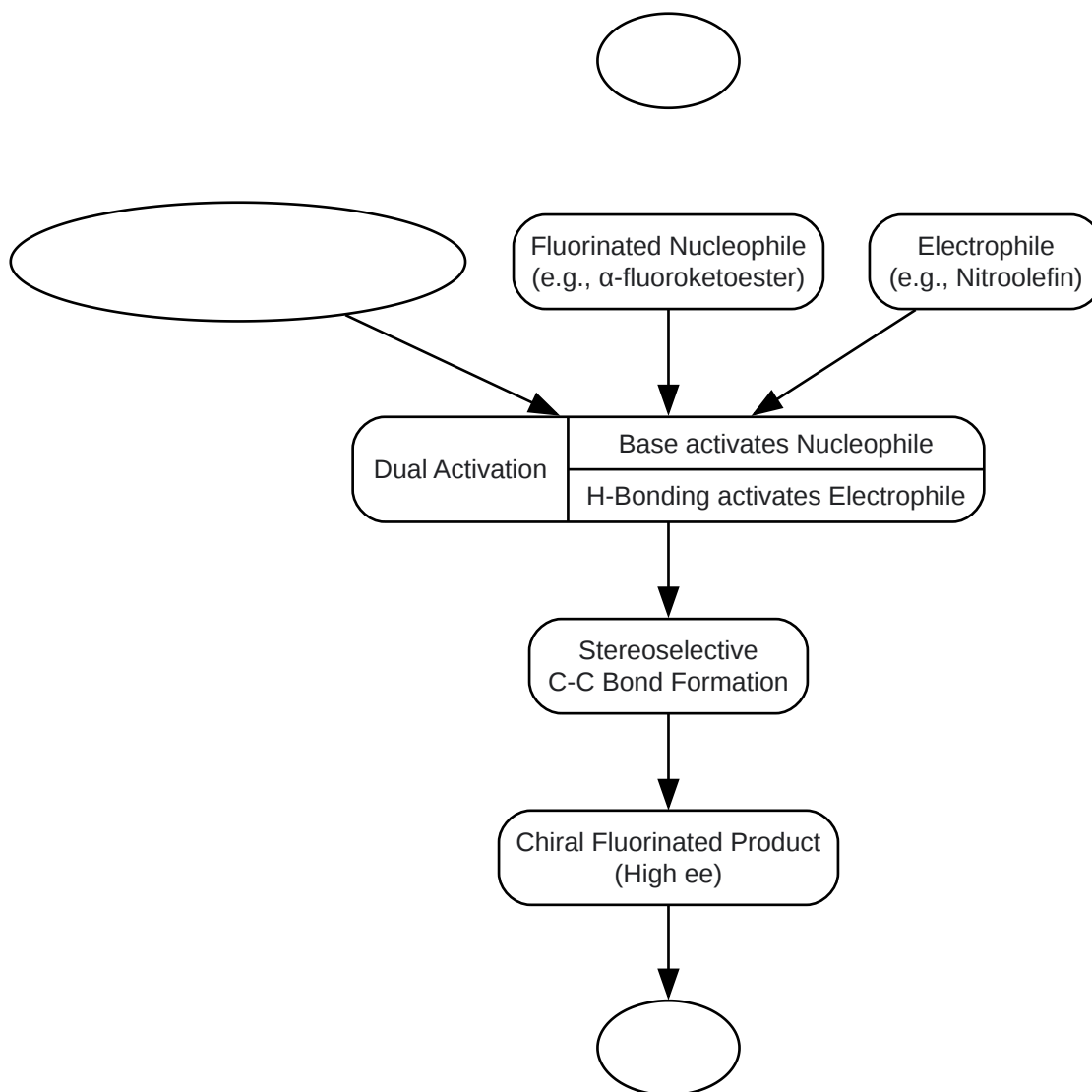

[Click to download full resolution via product page](#)

Caption: Logical workflow for organocatalytic asymmetric synthesis.

Performance Comparison

Organocatalysis excels in producing chiral fluorinated molecules with high stereocontrol, which is critical for pharmaceutical applications.

Catalyst	Substrates	Product Type	Yield	Enantiomeric Excess (ee)	Reference
Cinchona Alkaloid Derivative	α -Fluoroketoester + Nitroolefins	β -Ketoester with fluorinated quaternary carbon	75–98%	94–99%	[1]
Quinidine Derivative (Cat. 2)	Chalcone Derivative + Selectfluor	Fluorinated Flavanone	up to 99%	up to 96%	
[2.2]Paracyclophane-based Isothiourea	Carboxylic Acids + Fluorinating Agent	α -Fluoroesters	High	Excellent	[15]

Enzymatic Catalysis: The Green and Selective Approach

Biocatalysis, particularly using enzymes like lipases, offers a highly selective and environmentally benign route to fluorinated esters.[16][17] These reactions are typically performed under mild conditions (room temperature, neutral pH) and can achieve exceptional levels of chemo-, regio-, and enantioselectivity.[18]

Mechanism of Action: The Acyl-Enzyme Intermediate

Lipase-catalyzed synthesis proceeds via a two-step mechanism. First, the acyl donor (e.g., a fluorinated ester) reacts with a serine residue in the enzyme's active site to form a covalent acyl-enzyme intermediate, releasing the alcohol portion of the donor. In the second step, the nucleophile (an alcohol or amine) attacks this intermediate, transferring the acyl group to form the new product and regenerating the free enzyme.[18] For kinetic resolutions, the enzyme selectively acylates or deacylates one enantiomer of a racemic mixture, allowing for the separation of both enantiomers.[19][20]

Performance Comparison

Enzymes are unparalleled for kinetic resolutions of racemic fluorinated esters or acids, consistently delivering products with very high enantiomeric purity.

Enzyme (Source)	Substrates	Reaction Type	Yield	Enantiomeric Excess (ee)	Reference
Novozym® 435 (CALB)	Methyl 2-aminobenzoate + Ethyl 4-fluorobenzoate	N-acylation	High	N/A (for achiral)	[18]
Lipase PSIM (Burkholderia cepacia)	Racemic β -fluorophenyl-substituted β -amino ester hydrochlorides	Hydrolytic Kinetic Resolution	>48% (for each enantiomer)	$\geq 99\%$	[20][21]
Lipase P-30 (Pseudomonas)	Racemic ethyl 2-fluorohexanoate	Hydrolytic Kinetic Resolution	~40-75% conversion	High (not specified)	[19]

Experimental Protocol: Lipase-Catalyzed Kinetic Resolution of a Racemic Fluorinated Ester

This protocol is a representative example of an enzymatic resolution to obtain enantiomerically pure fluorinated compounds.[20][22]

Materials:

- Racemic fluorinated β -amino ester hydrochloride (e.g., 200 mg)
- Diisopropyl ether (iPr₂O, 10 mL)

- Immobilized Lipase PSIM (*Burkholderia cepacia*, 30 mg/mL)
- Triethylamine (Et₃N, 5 equivalents)
- Water (0.5 equivalents)

Procedure:

- **Reaction Setup:** In a screw-cap vial, dissolve the racemic ester hydrochloride in iPr₂O.
- **Reagent Addition:** Add Et₃N, water, and the immobilized lipase to the solution.
- **Incubation:** Seal the vial and place it in an orbital shaking incubator at 45°C.
- **Monitoring:** Monitor the reaction by HPLC to determine the conversion (aim for ~50%). Reaction times can vary from 8 to 72 hours depending on the substrate.
- **Separation:** Once ~50% conversion is reached, stop the reaction by filtering off the enzyme.
- **Isolation of Unreacted Ester:** Wash the filtered enzyme with diethyl ether. Combine the organic filtrates, dry over Na₂SO₄, and evaporate the solvent to obtain the unreacted (R)-ester.
- **Isolation of Product Acid:** Wash the filtered enzyme with distilled water to recover the product (S)-amino acid salt.

Overall Comparison and Conclusion

The optimal catalyst for synthesizing a fluorinated ester is highly dependent on the specific goals of the synthesis. Each class of catalyst offers a unique profile of advantages and limitations.

Catalyst Class	Primary Application	Key Advantage	Key Limitation	Cost/Sustainability
Lewis Acids	Bulk synthesis, aromatic substitution	High reactivity, well-established	Often stoichiometric, moisture-sensitive, waste generation	Low to moderate cost, lower sustainability
Brønsted Acids	General esterification	Metal-free, inexpensive	Equilibrium-limited, can cause side reactions	Low cost, moderate sustainability
Organocatalysts	Asymmetric synthesis	Excellent enantioselectivity, metal-free	Can require high catalyst loading, substrate-specific	Moderate to high cost, good sustainability
Enzymes	Kinetic resolutions, chiral synthesis	Exceptional selectivity, mild conditions, green	Sensitive to conditions, limited substrate scope	Variable cost, high sustainability

Concluding Remarks for the Practicing Scientist:

- For large-scale production of achiral fluorinated intermediates, particularly via aromatic substitution, traditional Lewis acids like AlCl_3 or FeCl_3 remain a pragmatic choice, balancing reactivity and cost.[6]
- When high enantiopurity is the primary objective, organocatalysis and enzymatic resolution are the premier strategies. Organocatalysts offer a direct route to chiral products[1], while enzymes provide an exceptionally effective method for resolving racemic mixtures into enantiopure compounds.[20]
- For syntheses demanding metal-free conditions or for standard esterifications where side reactions are a concern, Brønsted acids provide a simple and effective solution.

- As the field moves towards greener and more sustainable chemistry, the development of recyclable fluororous Lewis acids[7] and the broader application of biocatalysis[16] represent exciting frontiers in the synthesis of valuable fluorinated molecules.

References

- Li, H., Zhang, S., Yu, C., Song, X., & Wang, W. (2009). Organocatalytic asymmetric synthesis of chiral fluorinated quaternary carbon containing β -ketoesters. *Chemical Communications*, (16), 2136-2138. [[Link](#)]
- Arizona Board of Regents. (2009). Organocatalytic asymmetric synthesis of chiral fluorinated quaternary carbon containing β -ketoesters.
- Zhang, C., et al. (2021). Enzymatic synthesis of fluorinated compounds. *Applied Microbiology and Biotechnology*, 105, 8467–8484. [[Link](#)]
- Ruslan, I. (2012). Organocatalytic Strategies Towards Chiral Fluorinated Molecules as Precursors of Bioactive Compounds. ScholarBank@NUS. [[Link](#)]
- Wang, Y., & Deng, L. (2010).
- Li, H., et al. (2009). Organocatalytic asymmetric synthesis of chiral fluorinated quaternary carbon containing β -ketoesters.
- Zhang, C., et al. (2021). Enzymatic synthesis of fluorinated compounds. PubMed. [[Link](#)]
- Li, Y., et al. (2023). Brønsted acid-catalyzed synthesis of sulfinamidines and sulfinimidate esters through electrophilic fluorination and substitution. *Organic & Biomolecular Chemistry*. [[Link](#)]
- Kalaritis, P., & Regenye, R. W. (1990). Enantiomerically pure ethyl (R)- and (S)-2-fluorohexanoate by enzyme-catalyzed kinetic resolution. *Organic Syntheses*, 69, 10. [[Link](#)]
- ResearchGate. (n.d.). Comparative Study of the Strongest Solid Lewis Acid Catalysts Known: ACF and HS-AlF₃. ResearchGate. [[Link](#)]
- Shahmohammadi, S., Fülöp, F., & Forró, E. (2020). Efficient Synthesis of New Fluorinated β -Amino Acid Enantiomers through Lipase-Catalyzed Hydrolysis. *Molecules*, 25(24), 6013. [[Link](#)]

- Feng, Z., et al. (2024). Precise and selective asymmetric synthesis of fluorinated compounds via enzymatic approach. *The Innovation*, 5(2), 100585. [\[Link\]](#)
- Shahmohammadi, S., Fülöp, F., & Forró, E. (2020). Efficient Synthesis of New Fluorinated β -Amino Acid Enantiomers through Lipase-Catalyzed Hydrolysis. *PubMed*. [\[Link\]](#)
- Yu, H., et al. (2007). Enzymatic Synthesis of Fluorinated Mechanistic Probes for Sialidases and Sialyltransferases. *Journal of the American Chemical Society*, 129(37), 11438-11446. [\[Link\]](#)
- Ishihara, K., & Yamamoto, H. (2006). Development of Fluorous Lewis Acid-Catalyzed Reactions. *Accounts of Chemical Research*, 39(12), 877-885. [\[Link\]](#)
- ResearchGate. (2023). Brønsted Acid-Catalyzed Synthesis of Sulfinamidines and Sulfinimidate Esters through Electrophilic Fluorination and Substitution. *ResearchGate*. [\[Link\]](#)
- Fukushi, K., et al. (2016). Lewis Acid-Catalyzed Selective Mono-fluorination of Malonates Using Me-NFSI. *Fluorine Notes*, 2(105).
- ResearchGate. (n.d.). The effect of Brønsted acidity on catalysis. *ResearchGate*. [\[Link\]](#)
- ResearchGate. (2020). Efficient Synthesis of New Fluorinated β -Amino Acid Enantiomers through Lipase-Catalyzed Hydrolysis. *ResearchGate*. [\[Link\]](#)
- ResearchGate. (2012). Esterification of Carboxylic Acids Catalyzed by in situ Generated Tetraalkylammonium Fluorides. *ResearchGate*. [\[Link\]](#)
- Sandford, G. (n.d.). CHEM21 Case Study: Synthesis of 2-fluoromalonnate Esters Via Selective Direct Fluorination. *CHEM21*. [\[Link\]](#)
- TMP Chem. (2019). 01.04 Brønsted Acid Catalysis. *YouTube*. [\[Link\]](#)
- Cox, B. G., & Dunn, P. (1989). The Brønsted acid-catalysed hydrolysis of acyl fluorides in aqueous media. *Journal of the Chemical Society, Perkin Transactions 2*, (8), 1339-1343. [\[Link\]](#)
- Clark, J. (2023). Acid Catalyzed Hydrolysis of Esters. *Chemistry LibreTexts*. [\[Link\]](#)

- Organic Chemistry Portal. (n.d.). Synthesis of α -fluorocarboxylic acids and derivatives. Organic Chemistry Portal. [[Link](#)]

Need Custom Synthesis?

BenchChem offers custom synthesis for rare earth carbides and specific isotopic labeling.

Email: info@benchchem.com or [Request Quote Online](#).

Sources

- 1. Organocatalytic asymmetric synthesis of chiral fluorinated quaternary carbon containing β -ketoesters - Chemical Communications (RSC Publishing) [pubs.rsc.org]
- 2. Precise and selective asymmetric synthesis of fluorinated compounds via enzymatic approach [the-innovation.org]
- 3. DSpace [scholarbank.nus.edu.sg]
- 4. CHEM21 Case Study: Synthesis of 2-fluoromalonate Esters Via Selective Direct Fluorination – ACS GCI Pharmaceutical Roundtable [learning.acsgcipr.org]
- 5. pdf.benchchem.com [pdf.benchchem.com]
- 6. pdf.benchchem.com [pdf.benchchem.com]
- 7. Development of Fluorous Lewis Acid-Catalyzed Reactions - PMC [[pmc.ncbi.nlm.nih.gov](https://pubmed.ncbi.nlm.nih.gov)]
- 8. youtube.com [youtube.com]
- 9. chem.libretexts.org [chem.libretexts.org]
- 10. Brønsted acid-catalyzed synthesis of sulfinamidines and sulfinimidate esters through electrophilic fluorination and substitution - Organic & Biomolecular Chemistry (RSC Publishing) [pubs.rsc.org]
- 11. researchgate.net [researchgate.net]
- 12. The Brønsted acid-catalysed hydrolysis of acyl fluorides in aqueous media - Journal of the Chemical Society, Perkin Transactions 2 (RSC Publishing) [pubs.rsc.org]
- 13. experts.azregents.edu [experts.azregents.edu]
- 14. Organocatalytic asymmetric synthesis of chiral fluorinated quaternary carbon containing β -ketoesters - Chemical Communications (RSC Publishing) [pubs.rsc.org]
- 15. α -Fluorocaboxylic acid, ester, amide synthesis by fluorination [organic-chemistry.org]

- [16. Enzymatic synthesis of fluorinated compounds - PMC \[pmc.ncbi.nlm.nih.gov\]](#)
- [17. Enzymatic synthesis of fluorinated compounds - PubMed \[pubmed.ncbi.nlm.nih.gov\]](#)
- [18. pdf.benchchem.com \[pdf.benchchem.com\]](#)
- [19. Organic Syntheses Procedure \[orgsyn.org\]](#)
- [20. mdpi.com \[mdpi.com\]](#)
- [21. Efficient Synthesis of New Fluorinated \$\beta\$ -Amino Acid Enantiomers through Lipase-Catalyzed Hydrolysis - PubMed \[pubmed.ncbi.nlm.nih.gov\]](#)
- [22. researchgate.net \[researchgate.net\]](#)
- To cite this document: BenchChem. [Comparative study of catalysts for the synthesis of fluorinated esters]. BenchChem, [2026]. [Online PDF]. Available at: [\[https://www.benchchem.com/product/b1473821/docs#comparative-study-of-catalysts-for-the-synthesis-of-fluorinated-esters\]](https://www.benchchem.com/product/b1473821/docs#comparative-study-of-catalysts-for-the-synthesis-of-fluorinated-esters)

Disclaimer & Data Validity:

The information provided in this document is for Research Use Only (RUO) and is strictly not intended for diagnostic or therapeutic procedures. While BenchChem strives to provide accurate protocols, we make no warranties, express or implied, regarding the fitness of this product for every specific experimental setup.

Technical Support: The protocols provided are for reference purposes. Unsure if this reagent suits your experiment?

Need Industrial/Bulk Grade? [Request Custom Synthesis Quote](#)

BenchChem

Our mission is to be the trusted global source of essential and advanced chemicals, empowering scientists and researchers to drive progress in science and industry.

Contact

Address: 3281 E Guasti Rd

Ontario, CA 91761, United States

Phone: (601) 213-4426

Email: info@benchchem.com

Contact our Ph.D. Support Team for a compatibility check