

Application Note & Protocol: Elucidating Lithium Dynamics in Mercury

Author: BenchChem Technical Support Team. **Date:** May 2026

Compound of Interest

Compound Name: *Lithium;mercury*

CAS No.: *12372-31-5*

Cat. No.: *B14725451*

[Get Quote](#)

An Electrochemical Approach to Measuring Lithium Diffusion Coefficients in Amalgam

Introduction and Scientific Context

The study of liquid metal alloys, or amalgams, provides a unique window into fundamental electrochemical and metallurgical processes. Lithium-mercury amalgams are of particular interest due to their historical and ongoing relevance in electrochemistry, from their use as highly reproducible reference electrodes to their role in understanding the thermodynamics of alkali metal solutions.^[1] The diffusion coefficient of lithium within the mercury matrix is a critical parameter that governs the rate of mass transport and, consequently, the kinetics of electrochemical reactions at the amalgam-electrolyte interface.

This application note provides a comprehensive experimental framework for researchers to accurately determine the diffusion coefficient of lithium in mercury. We will detail two powerful and complementary electrochemical techniques: Cyclic Voltammetry (CV) and Chronopotentiometry (CP). The protocols are designed to be self-validating, explaining the causality behind each step to ensure both scientific rigor and experimental success.

Guiding Principles: The "Why" Behind the Method

The core of this experimental setup lies in creating a lithium-amalgam electrode and then electrochemically modulating the lithium concentration at the electrode surface. By precisely controlling either the potential (in CV) or the current (in CP) and measuring the resulting response, we can deduce the rate at which lithium atoms diffuse through the mercury to the interface.

- **Cyclic Voltammetry (CV):** This technique probes the redox behavior of the amalgam by sweeping the potential. The resulting peak current is limited by the rate at which lithium can diffuse to the electrode surface to be oxidized. The relationship between peak current and the scan rate is defined by the Randles-Ševčík equation, which allows for the calculation of the diffusion coefficient.[\[2\]](#)[\[3\]](#)[\[4\]](#)
- **Chronopotentiometry (CP):** In this method, a constant current is applied, forcing the oxidation of lithium at a steady rate. The potential of the electrode is monitored over time. The "transition time" (τ) is the point at which the surface concentration of lithium is depleted, causing a sharp change in potential. This transition time is directly related to the diffusion coefficient via the Sand equation.[\[1\]](#)[\[5\]](#)[\[6\]](#)

CRITICAL SAFETY PRECAUTIONS

Working with mercury and lithium presents significant hazards. Strict adherence to safety protocols is mandatory.

- **Mercury Hazard:** Mercury is a potent neurotoxin. All handling must occur in a dedicated, well-ventilated fume hood over a lipped tray to contain spills.[\[3\]](#)[\[7\]](#) Avoid all skin contact by using appropriate gloves (e.g., nitrile gloves).[\[8\]](#) A mercury spill kit must be readily available.[\[8\]](#)
- **Lithium Hazard:** Lithium metal reacts violently with water and moisture to produce flammable hydrogen gas and corrosive lithium hydroxide.[\[9\]](#) All handling of lithium metal and the prepared amalgam must be performed in an inert atmosphere (e.g., an argon-filled glove box).
- **Amalgam Waste:** All mercury- and amalgam-contaminated waste is considered hazardous. It must be collected in a sealed, clearly labeled container under a mercury-suppressing solution and disposed of through a licensed hazardous waste carrier.[\[3\]](#)[\[10\]](#)

- Personal Protective Equipment (PPE): At a minimum, safety glasses, a lab coat, and appropriate chemical-resistant gloves are required at all times.

Materials, Reagents, and Apparatus Equipment

- Potentiostat/Galvanostat with corresponding software
- Inert atmosphere glove box (Argon recommended)
- Fume Hood
- Three-electrode electrochemical cell (glass)
- Working Electrode (WE): Custom-made dropping mercury electrode or a static mercury pool electrode setup.
- Reference Electrode (RE): Silver/Silver Ion (Ag/Ag⁺) or other suitable non-aqueous reference electrode.
- Counter Electrode (CE): Platinum wire or mesh.
- Analytical Balance (readable to 0.1 mg)
- Magnetic Stirrer and stir bars
- Glassware: beakers, graduated cylinders, vials.
- Micropipettes

Chemicals and Reagents

- High-purity (e.g., triple-distilled) Mercury (Hg)
- Lithium (Li) metal (rod or foil, stored under mineral oil)
- Non-Aqueous Electrolyte:

- Solvent: Propylene Carbonate (PC) or a mixture of Ethylene Carbonate (EC) and Dimethyl Carbonate (DMC), battery grade.[9]
- Supporting Electrolyte Salt: 0.1 M to 1.0 M Lithium perchlorate (LiClO_4) or Lithium hexafluorophosphate (LiPF_6), battery grade.[9][10]
- Hexanes or Pentane (for washing lithium metal)
- Argon gas (high purity) for glove box and solution purging.

Experimental Protocols

PART A: Preparation of Lithium-Mercury Amalgam (Working Electrode)

This protocol is for preparing a dilute (~0.1 - 0.5 mol%) lithium amalgam. All steps must be performed within an argon-filled glove box.

- Prepare Mercury: Accurately weigh a specific amount of high-purity mercury (e.g., 20.0 g) into a small, clean, and dry glass beaker.
- Prepare Lithium:
 - Take a small piece of lithium metal from the oil.
 - In the glove box, carefully cut a small, clean piece of lithium.
 - Briefly wash the lithium piece in a beaker of hexanes to remove the protective mineral oil.
 - Allow the hexanes to fully evaporate.
 - Accurately weigh the required mass of clean lithium to achieve the target concentration. For example, for a 0.2 mol% Li amalgam with 20g of Hg (0.0997 mol), you would need approximately 1.4 mg of Li (0.0002 mol).
- Amalgamation:

- Causality: The amalgamation of lithium with mercury is an exothermic reaction. Adding the lithium in small portions prevents excessive heat generation and potential splashing.
- Carefully add the weighed lithium to the mercury. It should dissolve upon contact.^[11] Gentle stirring with a clean glass rod can facilitate the process.
- Homogenization: Allow the prepared amalgam to sit for at least one hour to ensure the lithium is homogeneously distributed throughout the mercury. This amalgam now serves as the working electrode.

PART B: Electrochemical Cell Assembly

- Transfer Amalgam: Carefully transfer the prepared lithium-mercury amalgam into the working electrode compartment of the electrochemical cell.
- Prepare Electrolyte: Inside the glove box, prepare the non-aqueous electrolyte solution (e.g., 0.5 M LiClO₄ in Propylene Carbonate).
- Assemble Cell:
 - Add the electrolyte to the electrochemical cell, ensuring the level is sufficient to cover all electrodes.
 - Insert the Counter Electrode (Pt wire) and the Reference Electrode (Ag/Ag⁺). Ensure the reference electrode tip is positioned close to the working electrode surface to minimize iR drop.
- Connect Electrodes: Connect the working, reference, and counter electrode leads to the potentiostat. The cell is now ready for electrochemical measurements.

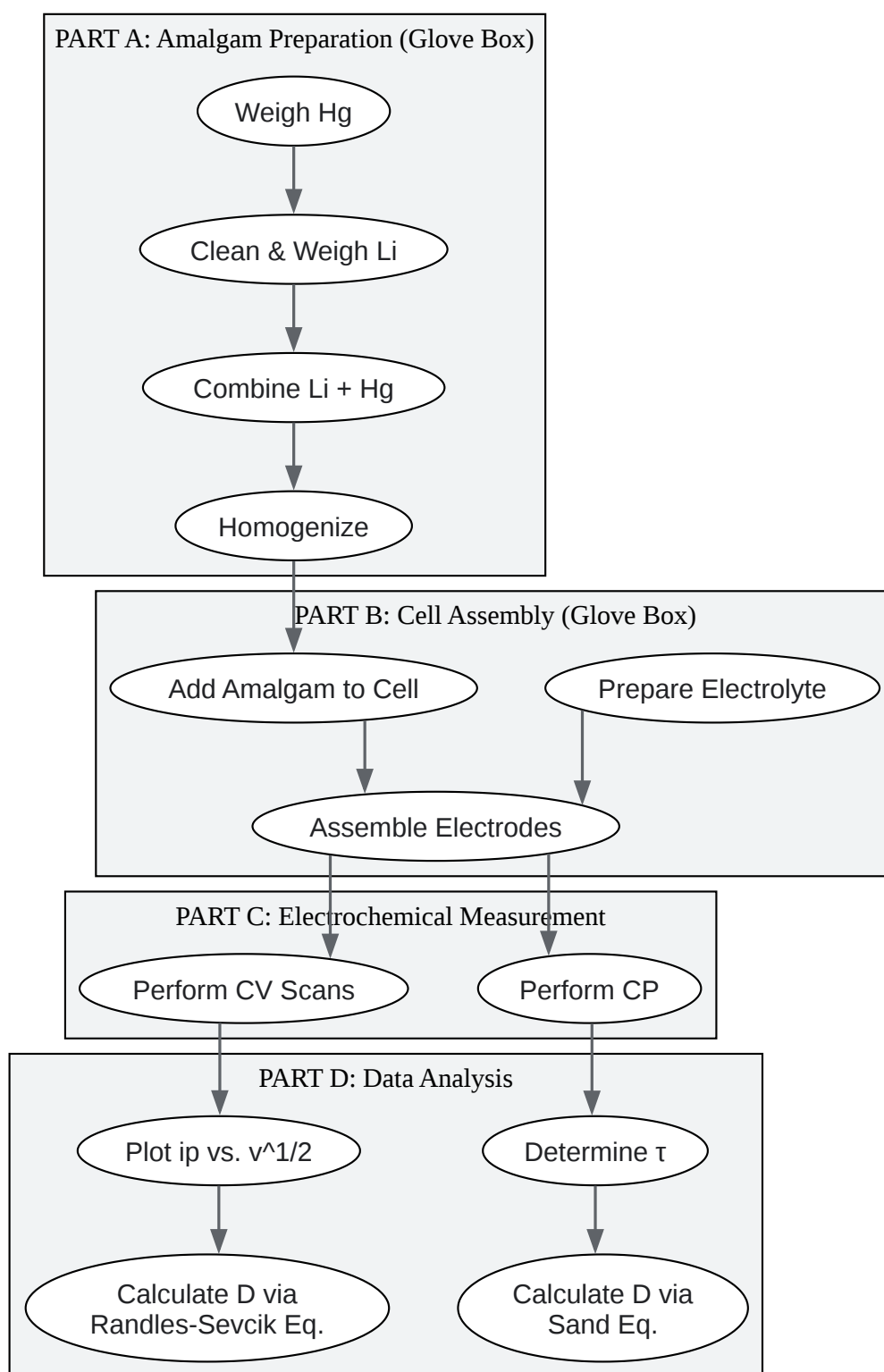

Overall Experimental Workflow

[Click to download full resolution via product page](#)

Caption: High-level overview of the experimental workflow.

PART C: Determination of Li Diffusion Coefficient

The following two methods can be performed sequentially on the same cell setup.

Method 1: Cyclic Voltammetry (CV)

- Set Parameters: In the potentiostat software, set up a cyclic voltammetry experiment.
 - Potential Window: Set the potential to scan from a value where no reaction occurs (e.g., Open Circuit Potential) to a potential sufficiently positive to oxidize the lithium in the amalgam, and then back. A suggested starting range is -3.0 V to -2.0 V vs. a Ag/Ag⁺ reference, but this should be determined empirically.
 - Scan Rates (v): Set up a series of experiments at different scan rates. A good range would be 20, 50, 75, 100, 150, and 200 mV/s.[\[12\]](#)
 - Cycles: 1-3 cycles per scan rate are usually sufficient.
- Run Experiment: Start the experiment. The software will record the current as a function of the applied potential for each scan rate.
- Data Acquisition: For each voltammogram, identify and record the peak anodic current (i_p).

Method 2: Chronopotentiometry (CP)

- Set Parameters: In the software, set up a chronopotentiometry experiment.
 - Applied Current (I): Choose a constant anodic current. The magnitude should be chosen to yield a transition time (τ) between 1 and 20 seconds for accurate measurement. This may require some trial and error.
 - Potential Limits: Set a high potential limit to terminate the experiment after the transition occurs.
- Run Experiment: Apply the constant current and record the potential as a function of time.
- Data Acquisition: From the resulting E-t curve, determine the transition time (τ). This is typically done by finding the inflection point of the rapid potential change. Repeat for several

different applied currents.

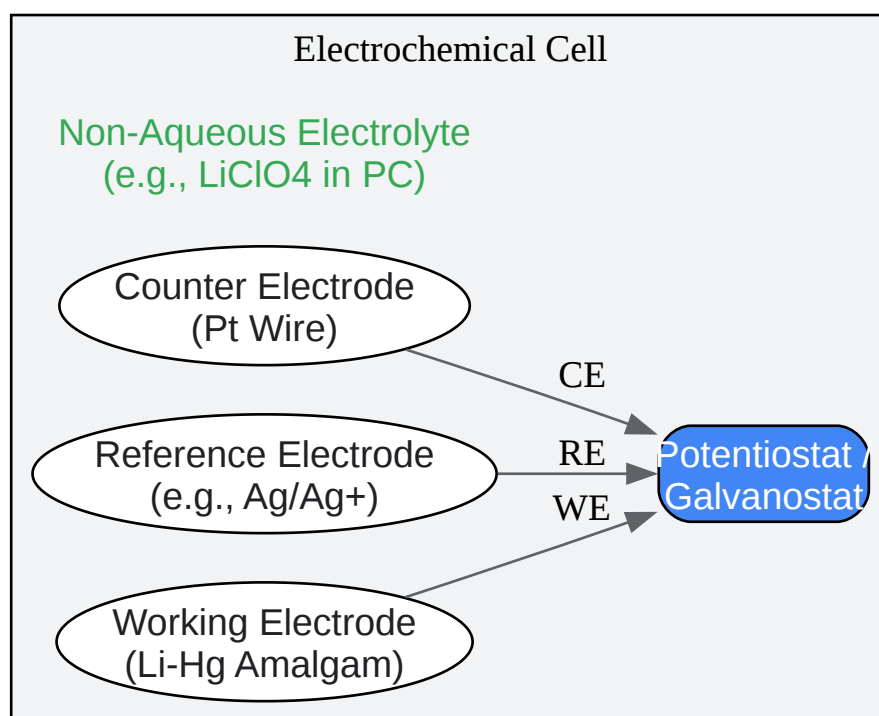

Three-Electrode Cell Setup

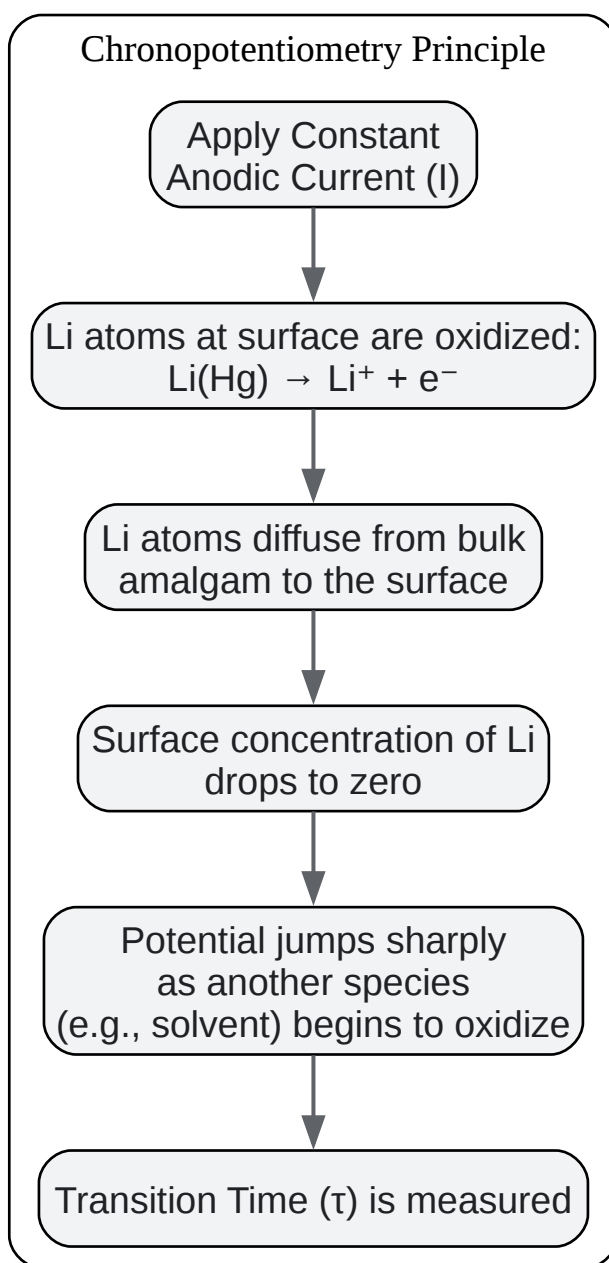

Principle of Chronopotentiometry for this system.

[Click to download full resolution via product page](#)

Caption: The principle of Chronopotentiometry for this system.

References

- Wikipedia. (n.d.). Lithium-ion battery. Retrieved from [\[Link\]](#)

- Kovács, A. (2021). Application of Chronopotentiometry in the Over-Limiting Current Density Range of Ion Exchange Membranes to Determine the Diffusion Coefficients of Electrolytes. In J. C. Taylor (Ed.), *Advances in Chemistry Research*. Volume 19 (pp. 183-206). Nova Science Publishers.
- Galluzzo, M. D., et al. (2020). Electrolyte additives to enable nonaqueous polyelectrolyte solutions for lithium ion batteries. *Molecular Systems Design & Engineering*. Retrieved from [\[Link\]](#)
- OrigaLys. (2025). Determination of diffusion coefficient of electroactive elements through Randles-Sevcik equation by Cyclic Voltammetry. Retrieved from [\[Link\]](#)
- Wikipedia. (n.d.). Randles–Ševčík equation. Retrieved from [\[Link\]](#)
- Li, Q., et al. (2024). A perspective on the fundamental theory of nonaqueous electrolytes for rechargeable batteries. *National Science Review*, Oxford Academic. Retrieved from [\[Link\]](#)
- Speiser, B., et al. (n.d.). Simultaneous Determination of Diffusion Coefficients and Electrode Radii. *Molecular ElectroChemistry*. Retrieved from [\[Link\]](#)
- Xu, K. (2004). Nonaqueous liquid electrolytes for lithium-based rechargeable batteries. *Chemical Reviews*, 104(10), 4303-4417.
- CalcTool. (2022). Randles–Sevcik Equation Calculator. Retrieved from [\[Link\]](#)
- Zhang, S. S. (2021). Nonaqueous Liquid Electrolytes for Lithium-Based Rechargeable Batteries. *ResearchGate*. Retrieved from [\[Link\]](#)
- Nikonenko, V. V., et al. (2018). Accounting for the concentration dependence of electrolyte diffusion coefficient in the Sand and the Peers equations. *ResearchGate*. Retrieved from [\[Link\]](#)
- ResearchGate. (n.d.). Relationship between the diffusion coefficient calculated using the Sand formula and the reciprocal of viscosity ($1/\eta$). Retrieved from [\[Link\]](#)
- Pine Research Instrumentation. (2024). Randles–Ševčík Equation. Retrieved from [\[Link\]](#)
- BASi. (2000). *Controlled Current Techniques*.

- Energy Storage and Conversion. (2020). Experimental measurement and analysis methods of cyclic voltammetry for lithium batteries. Retrieved from [\[Link\]](#)
- University of North Texas. (n.d.). Electrochemistry. UNT Chemistry. Retrieved from [\[Link\]](#)
- Rodríguez-López, J. (2014). Lithium Ion Quantification Using Mercury Amalgams as in Situ Electrochemical Probes in Nonaqueous Media. University of Texas at Austin. Retrieved from [\[Link\]](#)
- Myung, S.-T., et al. (2017). Applications of Voltammetry in Lithium Ion Battery Research. Journal of Electrochemical Science and Technology, 8(3), 188-200.
- Gamry Instruments. (n.d.). Cyclic Voltammetry Experiment. Retrieved from [\[Link\]](#)
- Molina, A., et al. (1982). Chronopotentiometry with Programmed Current at a Dropping Mercury Electrode. Analytical Chemistry, 54(7), 1091-1096.
- Marek, M. (1998). Cyclic voltammetry of dental amalgams. Journal of Dental Research, 77(7), 1511-1518.
- ResearchGate. (n.d.). Chronopotentiograms registered for a mercury concentration of 20 µg/L... Retrieved from [\[Link\]](#)
- Killen, R. M., et al. (2023). Detection of lithium in the exosphere of Mercury.

Need Custom Synthesis?

BenchChem offers custom synthesis for rare earth carbides and specific isotopic labeling.

Email: info@benchchem.com or [Request Quote Online](#).

Sources

- 1. [researchgate.net](https://www.researchgate.net) [[researchgate.net](https://www.researchgate.net)]
- 2. [origalys.com](https://www.origalys.com) [[origalys.com](https://www.origalys.com)]
- 3. Randles–Sevcik equation - Wikipedia [en.wikipedia.org]
- 4. Randles–Ševčík Equation | Pine Research Instrumentation [[pineresearch.com](https://www.pineresearch.com)]
- 5. [currentseparations.com](https://www.currentseparations.com) [[currentseparations.com](https://www.currentseparations.com)]

- [6. sites.chemistry.unt.edu \[sites.chemistry.unt.edu\]](https://sites.chemistry.unt.edu)
- [7. Molecular ElectroChemistry \[echem.uni-tuebingen.de\]](https://echem.uni-tuebingen.de)
- [8. scispace.com \[scispace.com\]](https://scispace.com)
- [9. Lithium-ion battery - Wikipedia \[en.wikipedia.org\]](https://en.wikipedia.org)
- [10. researchgate.net \[researchgate.net\]](https://researchgate.net)
- [11. chemistry.umbc.edu \[chemistry.umbc.edu\]](https://chemistry.umbc.edu)
- [12. Cyclic voltammetry of dental amalgams - PubMed \[pubmed.ncbi.nlm.nih.gov\]](https://pubmed.ncbi.nlm.nih.gov)
- To cite this document: BenchChem. [Application Note & Protocol: Elucidating Lithium Dynamics in Mercury]. BenchChem, [2026]. [Online PDF]. Available at: [\[https://www.benchchem.com/product/b14725451/docs#application-note-protocol-elucidating-lithium-dynamics-in-mercury\]](https://www.benchchem.com/product/b14725451/docs#application-note-protocol-elucidating-lithium-dynamics-in-mercury)

Disclaimer & Data Validity:

The information provided in this document is for Research Use Only (RUO) and is strictly not intended for diagnostic or therapeutic procedures. While BenchChem strives to provide accurate protocols, we make no warranties, express or implied, regarding the fitness of this product for every specific experimental setup.

Technical Support: The protocols provided are for reference purposes. Unsure if this reagent suits your experiment?

Need Industrial/Bulk Grade? [Request Custom Synthesis Quote](#)

BenchChem

Our mission is to be the trusted global source of essential and advanced chemicals, empowering scientists and researchers to drive progress in science and industry.

Contact

Address: 3281 E Guasti Rd

Ontario, CA 91761, United States

Phone: (601) 213-4426

Email: info@benchchem.com

Contact our Ph.D. Support Team for a compatibility check