

Creating Novel Therapeutics with a Cyclopropylamine Scaffold: Application Notes and Protocols

Author: BenchChem Technical Support Team. **Date:** April 2026

Compound of Interest

Compound Name: [1-(Fluoromethyl)cyclopropyl]methanamine

CAS No.: 1550947-28-8

Cat. No.: B1472486

[Get Quote](#)

Introduction: The Strategic Advantage of the Cyclopropylamine Scaffold

The cyclopropylamine motif is a privileged and versatile structure in medicinal chemistry, characterized by a highly strained three-membered carbocycle fused directly to an amino group[1]. The incorporation of this scaffold into a drug candidate is a deliberate strategic decision driven by its unique stereoelectronic properties. The inherent ring strain and "bent" carbon-carbon bonds impart a high degree of

character to the C-C bonds and

character to the C-H bonds[2].

This distinct profile restricts conformational flexibility, effectively locking the molecule into a rigid, planar bioactive conformation that minimizes the entropic penalty upon target receptor binding[2][3]. Furthermore, the electron-withdrawing nature of the cyclopropyl ring modulates the basicity of the adjacent amine, which can significantly improve pharmacokinetic properties, including metabolic stability against cytochrome P450 enzymes and enhanced blood-brain barrier permeability[2].

Mechanistic Causality: Targeting FAD-Dependent Enzymes

Historically recognized for their role as monoamine oxidase (MAO) inhibitors (e.g., tranylcypromine), cyclopropylamines have experienced a renaissance in oncology as potent, mechanism-based irreversible inhibitors of Lysine-Specific Demethylase 1 (LSD1)[4][5]. LSD1 is an epigenetic enzyme that represses gene transcription by demethylating mono- and dimethylated histone H3 lysine 4 (H3K4me1/2) via a flavin adenine dinucleotide (FAD)-dependent amine oxidation reaction[6].

The Mechanism of Inactivation: When a cyclopropylamine-based inhibitor enters the LSD1 active site, the enzyme attempts to oxidize the amine. This catalytic initiation triggers a single-electron transfer (SET) or radical-mediated ring opening of the highly strained cyclopropane ring[4][7]. The resulting reactive intermediate undergoes Grob fragmentation or direct radical attack, forming a covalent adduct with the FAD cofactor[4][6]. This irreversible modification halts LSD1 activity, leading to the accumulation of methylated H3K4 and the subsequent reactivation of silenced tumor suppressor genes[8].

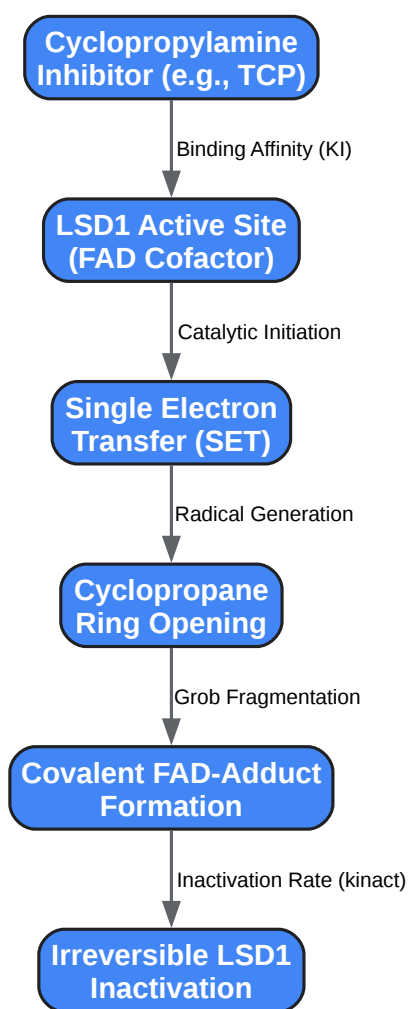

[Click to download full resolution via product page](#)

Mechanism of LSD1 inactivation by cyclopropylamine via FAD covalent modification.

Quantitative Data: Kinetic Parameters of Cyclopropylamine Derivatives

Selectivity between MAO and LSD1 is a critical parameter in modern drug design. Structural modifications, such as stereochemistry (cis vs. trans) and the substitution pattern on the cyclopropane ring, drastically alter target affinity and the rate of irreversible inactivation (

).

Compound	Target	Affinity / Inhibition	Kinetic Parameter	Reference
trans-2-Phenylcyclopropylamine (TCP)	LSD1	$= 242 \mu\text{M}$	$= 0.0106 \text{ s}^{-1}$	[4]
trans-2-Phenylcyclopropylamine (TCP)	MAO-A	$\text{IC}_{50} \sim 2.3 \mu\text{M}$	Irreversible	[5]
cis-N-benzyl-2-methoxycyclopropylamine	MAO-B	$\text{IC}_{50} = 5 \text{ nM}$	Irreversible	[9]
cis-N-benzyl-2-methoxycyclopropylamine	MAO-A	$\text{IC}_{50} = 170 \text{ nM}$	Irreversible	[9]
cis-N-benzyl-2-methoxycyclopropylamine	LSD1	No inhibition	N/A	[9]

Synthetic Methodology: Diastereoselective Synthesis of trans-Cyclopropylamines

Achieving high diastereoselectivity is a major hurdle in synthesizing substituted cyclopropylamines, as traditional methods often yield thermodynamic mixtures[1][10]. The following protocol leverages α -chloroaldehydes and bis(iodozincio)methane to generate an electrophilic zinc homoenolate, which is subsequently trapped by an amine[10].

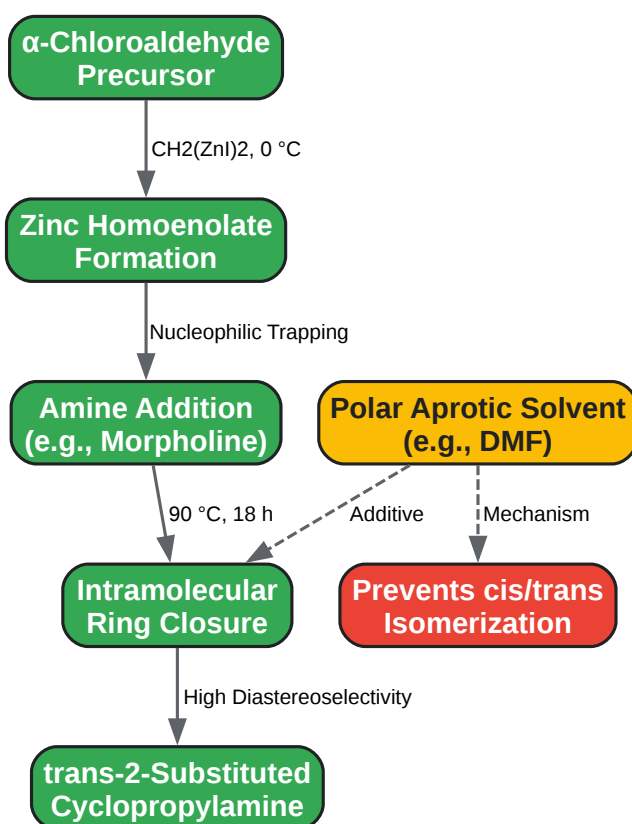

[Click to download full resolution via product page](#)

Synthetic workflow for trans-2-substituted cyclopropylamines via zinc homoenolates.

Protocol 1: Synthesis of trans-2-Substituted-Cyclopropylamines

Objective: Synthesize trans-2-substituted-cyclopropylamines with high diastereomeric ratio (d.r. > 20:1) from α -chloroaldehydes.

Materials:

- α -Chloroaldehyde precursor (1.0 equiv)
- Bis(iodozincio)methane () solution (1.5 equiv)
- Primary or secondary amine (e.g., morpholine) (2.0 equiv)
- Anhydrous N,N-Dimethylformamide (DMF)
- Anhydrous Tetrahydrofuran (THF)

Step-by-Step Procedure:

- **Homoenolate Formation:** In an oven-dried Schlenk flask under an argon atmosphere, dissolve the α -chloroaldehyde in anhydrous THF. Cool the solution to 0 °C.
- **Zinc Reagent Addition:** Dropwise add the solution to the flask. Stir the mixture at 0 °C for 1 hour to ensure complete formation of the zinc homoenolate intermediate[10].
- **Solvent Exchange/Additive (Critical Step):** Introduce anhydrous DMF to the reaction mixture.
 - **Causality Note:** In the absence of a polar aprotic co-solvent, ring-closure is reversible, yielding a thermodynamic mixture (\approx 5:1 d.r.). DMF acts as a Lewis basic co-solvent that coordinates with zinc halide byproducts, effectively turning off the reversible ring-opening that leads to cis/trans isomerization[10].
- **Amine Trapping:** Add the desired amine (e.g., morpholine) dropwise to the reaction mixture[10].
- **Ring Closure:** Heat the reaction mixture to 90 °C and stir for 18 hours to drive the intramolecular ring closure[10].
- **Workup:** Cool to room temperature, quench with saturated aqueous , and extract with ethyl acetate (3x). Wash the combined organic layers with brine, dry over anhydrous , and concentrate under reduced pressure.
- **Purification:** Purify the crude residue via silica gel flash chromatography to isolate the pure trans-2-substituted-cyclopropylamine.

Biological Evaluation Protocol: Validating Mechanism-Based Inhibition

Because cyclopropylamines act as suicide inhibitors (mechanism-based inactivators), standard

assays are insufficient and often misleading. Their apparent potency shifts depending on the pre-incubation time with the enzyme[4][9]. To build a self-validating data package, researchers must determine the inhibitor dissociation constant (

) and the maximum rate of inactivation (

).

Protocol 2: In Vitro LSD1 Demethylase Inactivation Assay

Objective: Validate the irreversible inhibition of LSD1 by synthesized cyclopropylamine derivatives and calculate

.

Step-by-Step Procedure:

- **Enzyme Pre-incubation:** Incubate recombinant human LSD1 enzyme (50 nM) with varying concentrations of the cyclopropylamine inhibitor (0.1 μ M to 1000 μ M) in assay buffer (50 mM Tris-HCl pH 7.5, 50 mM KCl, 2 mM CHAPS) at 25 °C.

- Time-Dependent Analysis: Aliquot samples at distinct pre-incubation time points (e.g., 0, 15, 30, and 60 minutes).
 - Causality Note: Pre-incubation is mandatory. If the compound is a true mechanism-based inhibitor, the degree of inhibition will increase over time as more of the enzyme population becomes covalently modified[4][9].
- Substrate Addition: Initiate the demethylase reaction by adding a synthetic histone H3K4me2 peptide substrate (20 μ M) coupled with Amplex Red (50 μ M) and horseradish peroxidase (HRP, 1 U/mL).
- Fluorescence Detection: Measure the production of hydrogen peroxide ()—a direct stoichiometric byproduct of the FAD-dependent amine oxidation—via Amplex Red fluorescence (Excitation: 530 nm, Emission: 590 nm) using a microplate reader.
- Data Analysis: Plot the remaining enzymatic activity (initial velocity) against pre-incubation time to find the observed rate of inactivation () for each concentration. Fit the data to the Michaelis-Menten-like equation for mechanism-based inhibition () to extract and [4].

References[4] trans-2-Phenylcyclopropylamine is a mechanism-based inactivator of the histone demethylase LSD1.

Scholars@Duke.<https://scholars.duke.edu/display/pub724037>[9] cis-Cyclopropylamines as mechanism-based inhibitors of monoamine oxidases. PubMed.<https://pubmed.ncbi.nlm.nih.gov/25755053/>[2] 2,2-Dicyclopropylethan-1-amine | 142913-40-4. Benchchem.

<https://www.benchchem.com/product/b1407720>[5] The Cyclopropylamine Scaffold: A Historical and Technical Guide to Tranylcyproamine as a Pharmacological Research Tool.

Benchchem.<https://www.benchchem.com/document/the-cyclopropylamine-scaffold-a-historical-and-technical-guide-to-tranylcyproamine-as-a-pharmacological-research-tool>[6] Structural Basis for the Inhibition of the LSD1 Histone Demethylase by the Antidepressant trans-2-Phenylcyclopropylamine. ACS Publications.<https://pubs.acs.org/doi/10.1021/bi700664y>[10]

Synthesis of trans-2-Substituted-Cyclopropylamines from α -

Chloroaldehydes. Semantic

Scholar.[https://www.semanticscholar.org/paper/Synthesis-of-trans-2-Substituted-Cyclopropylamines-Larin-](https://www.semanticscholar.org/paper/Synthesis-of-trans-2-Substituted-Cyclopropylamines-Larin-Panteleev/49527715017df85b31c62b6628c6ce9b321a50a3)

[49527715017df85b31c62b6628c6ce9b321a50a3](https://www.semanticscholar.org/paper/Synthesis-of-trans-2-Substituted-Cyclopropylamines-Larin-Panteleev/49527715017df85b31c62b6628c6ce9b321a50a3)[3] (6-Bromo-pyridazin-3-yl)-cyclopropyl-amine.

Benchchem.<https://www.benchchem.com/product/b1473950>[7] (A) Mechanism of catalysis for LSD1; (B) Structures of representative LSD1 inhibitors; (C) Mechanism of cyclopropylamine containing LSD1 inhibitors.

ResearchGate.https://www.researchgate.net/figure/A-Mechanism-of-catalysis-for-LSD1-B-Structures-of-representative-LSD1-inhibitors-C_fig1_349942704[1] Advances in the Synthesis of

Cyclopropylamines. ACS

Publications.<https://pubs.acs.org/doi/10.1021/acs.chemrev.4c00465>[8]

An In-Depth Technical Guide to the Mechanism of...

Benchchem.<https://www.benchchem.com/document/an-in-depth-technical-guide-to-the-mechanism-of-action-and-research-applications-of-gsk2879552>

Need Custom Synthesis?

BenchChem offers custom synthesis for rare earth carbides and specific isotopic labeling.

Email: info@benchchem.com or [Request Quote Online](#).

Sources

- 1. pubs.acs.org [pubs.acs.org]
- 2. 2,2-Dicyclopropylethan-1-amine | 142913-40-4 | Benchchem [[benchchem.com](https://www.benchchem.com)]
- 3. (6-Bromo-pyridazin-3-yl)-cyclopropyl-amine|CAS 1353972-18-5 [[benchchem.com](https://www.benchchem.com)]
- 4. Scholars@Duke publication: trans-2-Phenylcyclopropylamine is a mechanism-based inactivator of the histone demethylase LSD1. [scholars.duke.edu]
- 5. pdf.benchchem.com [pdf.benchchem.com]
- 6. pubs.acs.org [pubs.acs.org]
- 7. [researchgate.net](https://www.researchgate.net) [[researchgate.net](https://www.researchgate.net)]
- 8. pdf.benchchem.com [pdf.benchchem.com]

- [9. cis-Cyclopropylamines as mechanism-based inhibitors of monoamine oxidases - PubMed \[pubmed.ncbi.nlm.nih.gov\]](#)
- [10. pdfs.semanticscholar.org \[pdfs.semanticscholar.org\]](#)
- To cite this document: BenchChem. [Creating Novel Therapeutics with a Cyclopropylamine Scaffold: Application Notes and Protocols]. BenchChem, [2026]. [Online PDF]. Available at: [<https://www.benchchem.com/product/b1472486/docs#creating-novel-therapeutics-with-a-cyclopropylamine-scaffold-application-notes-and-protocols>]

Disclaimer & Data Validity:

The information provided in this document is for Research Use Only (RUO) and is strictly not intended for diagnostic or therapeutic procedures. While BenchChem strives to provide accurate protocols, we make no warranties, express or implied, regarding the fitness of this product for every specific experimental setup.

Technical Support: The protocols provided are for reference purposes. Unsure if this reagent suits your experiment?

Need Industrial/Bulk Grade? [Request Custom Synthesis Quote](#)

BenchChem

Our mission is to be the trusted global source of essential and advanced chemicals, empowering scientists and researchers to drive progress in science and industry.

Contact

Address: 3281 E Guasti Rd

Ontario, CA 91761, United States

Phone: (601) 213-4426

Email: info@benchchem.com

[Contact our Ph.D. Support Team for a compatibility check](#)