

Technical Support Center: Optimizing Suzuki Coupling of Bromopyridines

Author: BenchChem Technical Support Team. **Date:** May 2026

Compound of Interest

Compound Name: 3-Bromo-2-(trifluoromethyl)pyridine

CAS No.: 590371-58-7

Cat. No.: B1280465

[Get Quote](#)

A Guide for Researchers, Scientists, and Drug Development Professionals

The Suzuki-Miyaura cross-coupling reaction is a cornerstone in modern synthetic chemistry, particularly vital in pharmaceutical research and development for constructing biaryl and hetero-biaryl scaffolds found in many biologically active molecules.^{[1][2]} However, the coupling of bromopyridines presents unique challenges due to the electronic properties of the pyridine ring. The lone pair of electrons on the pyridine nitrogen can coordinate with the palladium catalyst, leading to inhibition and reduced yields.^{[3][4]} This guide provides in-depth troubleshooting advice and frequently asked questions (FAQs) to help you navigate and optimize these critical reactions, focusing on the crucial roles of the base and solvent.

Troubleshooting Common Issues

Low yields in the Suzuki coupling of bromopyridines are a frequent hurdle. A systematic evaluation of each reaction component—catalyst, ligand, base, and solvent—is the most effective troubleshooting strategy.^[3]

Problem 1: Low or No Product Formation

This is the most common issue, often pointing to problems with catalyst activity, reaction conditions, or reagent quality.

Initial Diagnostic Questions:

- Is the catalyst system active? Catalyst inhibition by the pyridine nitrogen is a primary suspect.[4]
- Are the reaction conditions optimal? Temperature, concentration, and stirring can significantly impact the outcome.
- Are the reagents high quality and under an inert atmosphere? Oxygen can promote undesirable side reactions like homocoupling.[3]

Solutions & Optimization Strategies:

- Catalyst and Ligand Selection: The choice of ligand is critical. Bulky, electron-rich phosphine ligands like SPhos, XPhos, and RuPhos can sterically shield the palladium center, preventing coordination with the pyridine nitrogen and promoting the oxidative addition step. [3][5] Air- and moisture-stable precatalysts can also offer more consistent results.[3]
- Reaction Temperature: Increasing the reaction temperature, typically in the range of 80-110 °C, can enhance the rate of reaction, especially for less reactive bromopyridines.[3][4] However, be cautious, as excessive heat can lead to catalyst decomposition.[6]
- Inert Atmosphere: It is crucial to thoroughly degas all solvents and the reaction mixture. This can be achieved by sparging with an inert gas like argon or nitrogen, or through freeze-pump-thaw cycles.[3] Maintain a positive pressure of inert gas throughout the reaction.

Problem 2: Significant Side Product Formation

Several side reactions can compete with the desired cross-coupling, consuming starting materials and complicating purification.

Common Side Reactions:

- Protodeboronation: The cleavage of the C-B bond in the boronic acid or its derivatives. This is often exacerbated by elevated temperatures and aqueous basic conditions.[7]
- Homocoupling: The self-coupling of the boronic acid or the bromopyridine. The presence of oxygen is a major contributor to this side reaction.[3][7]
- Debromination: The replacement of the bromine atom on the pyridine ring with a hydrogen atom.

Solutions & Optimization Strategies:

- Minimizing Protodeboronation:
 - Use More Stable Boron Reagents: Boronic esters (e.g., pinacol esters) or potassium trifluoroborate salts are generally more stable than boronic acids and less prone to protodeboronation.[3][8]
 - Careful Base Selection: The choice of base can influence the rate of protodeboronation. Anhydrous conditions using a base like K_3PO_4 can be beneficial.[5]
- Preventing Homocoupling:
 - Strict Inert Atmosphere: Rigorous degassing of solvents and the reaction mixture is the most effective way to minimize homocoupling.[3][7]
 - Use a Pd(0) Source: Using a pre-formed Pd(0) catalyst, such as $Pd(PPh_3)_4$, may reduce homocoupling that can occur during the in-situ reduction of a Pd(II) precatalyst.[7]
- Addressing Debromination:
 - Avoid Hydride Sources: Ensure that solvents and reagents are free from potential hydride sources. For instance, some grades of THF can contain peroxides that may lead to the formation of hydride donors.[9]

Frequently Asked Questions (FAQs)

Base Selection

Q1: What is the role of the base in the Suzuki coupling reaction?

The base plays multiple crucial roles in the catalytic cycle.^[10] It is required to activate the boronic acid, facilitating the transmetalation step where the organic group is transferred from boron to the palladium center.^{[10][11]} The base also participates in the formation of the active palladium complex.^[10]

Q2: Which base should I choose for my bromopyridine coupling?

There is no single "best" base, as the optimal choice depends on the specific substrates and solvent. However, a good starting point is to screen common inorganic bases.

- Potassium Carbonate (K_2CO_3): A widely used and often effective base, typically in an aqueous solvent mixture.^[5]
- Potassium Phosphate (K_3PO_4): A stronger base that is often effective when weaker bases fail. It can be used in anhydrous conditions, which can help minimize protodeboronation.^{[5][6]}
- Cesium Carbonate (Cs_2CO_3): A strong base that can be highly effective, particularly for challenging couplings.^[6]
- Potassium Fluoride (KF): A milder base that can be useful when base-sensitive functional groups are present in the starting materials.^{[11][12]}

Q3: How does the strength and solubility of the base affect the reaction?

The strength and solubility of the base can significantly impact the reaction rate and yield.^[6] A base that is too weak may not sufficiently activate the boronic acid, leading to a sluggish or incomplete reaction. Conversely, a base that is too strong can promote side reactions. The solubility of the base in the chosen solvent system is also important for ensuring efficient reaction.

Solvent Selection

Q4: What are the best solvents for Suzuki coupling of bromopyridines?

The solvent's primary role is to solubilize the reactants and catalyst. The choice of solvent can also influence reaction kinetics and selectivity.^{[6][13]} Common solvents and solvent systems

include:

- Toluene/Water or Dioxane/Water Mixtures: These are classic solvent systems for Suzuki couplings, providing a good balance of polarity to dissolve both the organic and inorganic components.[\[6\]](#)[\[14\]](#)
- Tetrahydrofuran (THF)/Water: Another common biphasic system.[\[5\]](#)
- N,N-Dimethylformamide (DMF): A polar aprotic solvent that can be effective for solubilizing difficult substrates.[\[12\]](#)[\[15\]](#)

Q5: Are there any solvents I should avoid?

Yes. Chlorinated solvents, acetonitrile, and pyridine itself should generally be avoided as they can coordinate to and inhibit the palladium catalyst.[\[6\]](#)

Visualizing the Process

The Suzuki-Miyaura Catalytic Cycle

The reaction proceeds through a well-defined catalytic cycle involving oxidative addition, transmetalation, and reductive elimination.[\[14\]](#)[\[16\]](#)

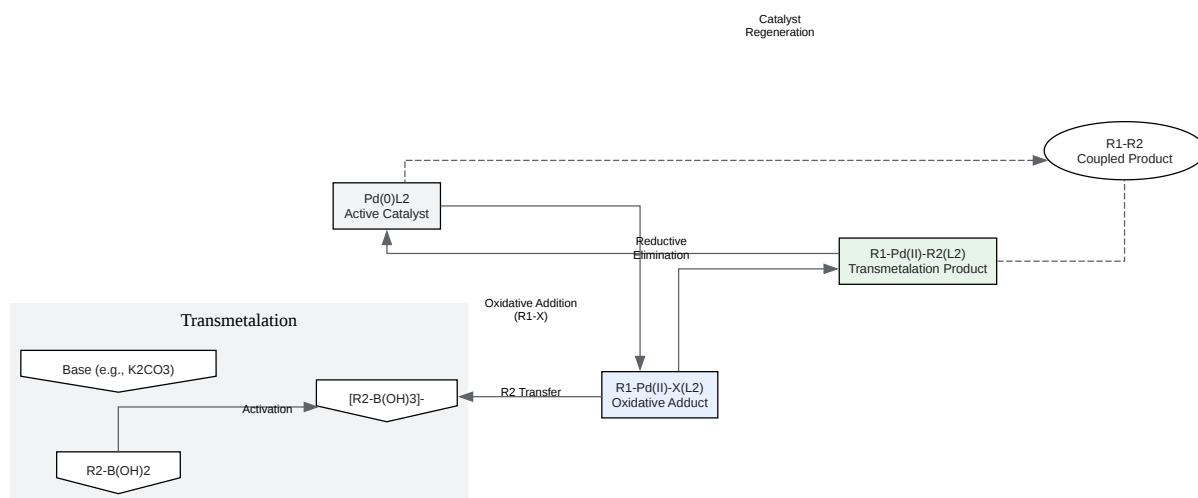

[Click to download full resolution via product page](#)

Caption: The catalytic cycle of the Suzuki-Miyaura coupling reaction.[6]

Troubleshooting Decision Tree

A systematic approach is key to solving low-yield reactions.

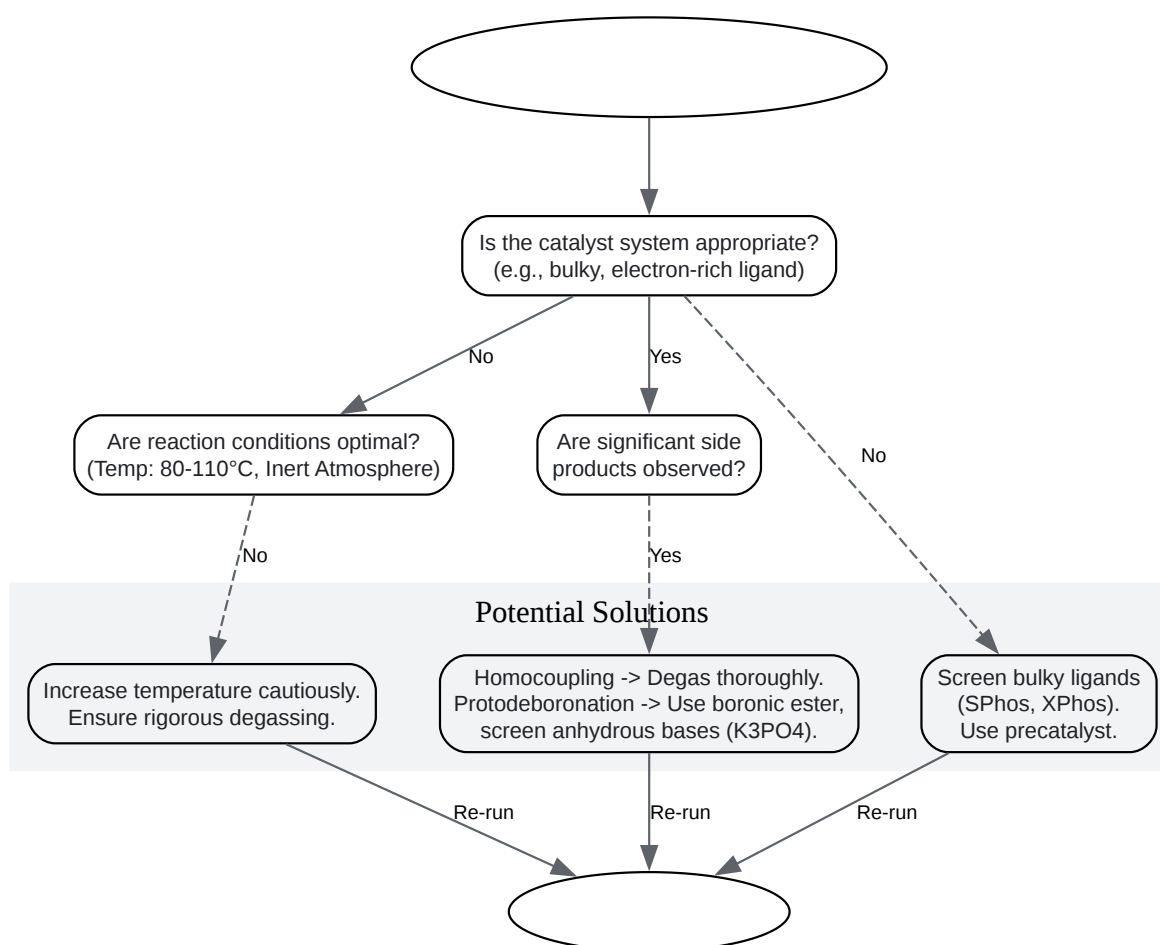

[Click to download full resolution via product page](#)

Caption: A decision tree for troubleshooting low-yielding Suzuki coupling reactions.[4]

Experimental Protocols

Protocol 1: General Procedure for Suzuki Coupling of a Bromopyridine

This protocol is a representative example and may require optimization for specific substrates.

- Reaction Setup: In a dry Schlenk tube or reaction vial under an inert atmosphere (argon or nitrogen), combine the bromopyridine (1.0 mmol), arylboronic acid (1.2 mmol), and base

(e.g., K_2CO_3 , 2.0 mmol).[4][17]

- Catalyst Addition: Add the palladium source (e.g., $Pd_2(dba)_3$, 1-2 mol%) and the ligand (e.g., SPhos, 2-4 mol%).
- Solvent Addition: Add the degassed solvent system (e.g., 1,4-Dioxane/water, 4:1) via syringe.[4]
- Degassing: Seal the vessel and subject the reaction mixture to three cycles of vacuum and backfilling with the inert gas to ensure an oxygen-free environment.[6]
- Reaction: Heat the mixture to the desired temperature (typically 80-110 °C) with vigorous stirring.[3]
- Monitoring: Monitor the reaction's progress using a suitable analytical technique such as TLC, GC-MS, or LC-MS.[3]
- Work-up: Once complete, cool the mixture to room temperature. Dilute with an organic solvent (e.g., ethyl acetate) and wash with water or brine.
- Purification: Dry the organic layer over anhydrous sodium sulfate, filter, and concentrate under reduced pressure. The crude product can then be purified by flash column chromatography.[4]

Protocol 2: Screening Bases and Solvents

For challenging substrates, a systematic screen of bases and solvents is often necessary. This can be performed on a small scale using a parallel synthesis platform.

- Array Setup: In an array of reaction vials, dispense the bromopyridine (1.0 equiv) and boronic acid (1.2 equiv).
- Variable Addition:
 - Bases: To designated vials, add different bases (e.g., K_2CO_3 , K_3PO_4 , CS_2CO_3 , KF; 2.0 equiv each).

- Solvents: To designated vials, add different degassed solvents (e.g., Toluene/H₂O, Dioxane/H₂O, THF/H₂O, DMF).
- Catalyst Addition: Prepare a stock solution of the catalyst system (e.g., Pd₂(dba)₃ and SPhos) in the primary solvent (e.g., Dioxane) and dispense it into each vial.
- Reaction & Analysis: Seal the vials, heat to the desired temperature, and stir. After a set time, quench the reactions and analyze the outcomes by LC-MS or GC-MS to determine the optimal conditions.

Data Summary Tables

Table 1: Common Bases for Suzuki Coupling

Base	Typical Conditions	Key Characteristics
K ₂ CO ₃	Aqueous solvent mixture (e.g., Dioxane/H ₂ O)	Standard, versatile, and cost-effective.[6]
K ₃ PO ₄	Anhydrous or aqueous conditions	Stronger base, good for less reactive substrates and can minimize protodeboronation.[6]
Cs ₂ CO ₃	Anhydrous or aqueous conditions	Highly effective, often used for challenging couplings.[6]
KF	Anhydrous or aqueous conditions	Mild base, suitable for substrates with base-sensitive functional groups.[18]

Table 2: Common Solvents for Suzuki Coupling

Solvent System	Polarity	Typical Temperature Range	Notes
Toluene / H ₂ O	Biphasic	80 - 110 °C	Good for a wide range of substrates.[6]
1,4-Dioxane / H ₂ O	Biphasic, Polar Organic	80 - 100 °C	Excellent solubilizing properties for many reactants.[6]
THF / H ₂ O	Biphasic, Polar Organic	60 - 80 °C	Lower boiling point may limit reaction temperature.
DMF	Polar Aprotic	80 - 120 °C	Good for poorly soluble substrates, but can be difficult to remove.[12]

References

[3] Benchchem. (2026, January). troubleshooting low yield in Suzuki coupling of bromopyridines. BenchChem.

[4] Benchchem. Technical Support Center: Troubleshooting Low Yields in Suzuki Coupling of 2-Bromopyridines. BenchChem.

[9] Benchchem. (2025, December). Technical Support Center: Suzuki Coupling of 2-Bromopyridines. BenchChem.

[6] Benchchem. Technical Support Center: Optimizing Suzuki Coupling Reactions with 3-Bromo-5-(methoxymethyl)pyridine. BenchChem.

[10] Wikipedia. Suzuki reaction.

[16] Chemistry LibreTexts. (2024, October 10). Suzuki-Miyaura Coupling.

[14] NROChemistry. Suzuki Coupling: Mechanism & Examples.

- [8] Yoneda Labs. Suzuki-Miyaura cross-coupling: Practical Guide.
- [11] Organic Chemistry Portal. Suzuki Coupling.
- [18] Billingsley, K. L., & Buchwald, S. L. (2008). A General and Efficient Method for the Suzuki-Miyaura Coupling of 2-Pyridyl Nucleophiles. *Angewandte Chemie International Edition*, 47(37), 7129–7132.
- [1] Benchchem. Suzuki Coupling of Pyridyl Halides: A Comparative Guide to the Reactivity of Chloropyridines and Bromopyridines. BenchChem.
- [7] Benchchem. Technical Support Center: Optimizing Suzuki Coupling for Bromopyrroles. BenchChem.
- [15] ResearchGate. (n.d.). Optimizations of the Suzuki coupling of 3-bromopyridine with potassium...
- [5] Reddit. (2024, February 23). How to approach choosing reaction conditions for Suzuki? r/Chempros.
- [13] Newman, S. G., & Willis, M. C. (2020). Solvent Effects on the Selectivity of Palladium-Catalyzed Suzuki-Miyaura Couplings. *Israel Journal of Chemistry*, 60(3-4), 406–409.
- [2] Carey, J. S. (2020). Impact of Cross-Coupling Reactions in Drug Discovery and Development. *Molecules*, 25(15), 3486.
- [12] ResearchGate. (2014, December 23). How can I solve my problem with Suzuki coupling?

Need Custom Synthesis?

BenchChem offers custom synthesis for rare earth carbides and specific isotopic labeling.

Email: info@benchchem.com or [Request Quote Online](#).

Sources

- 1. pdf.benchchem.com [pdf.benchchem.com]

- [2. Impact of Cross-Coupling Reactions in Drug Discovery and Development - PMC \[pmc.ncbi.nlm.nih.gov\]](#)
- [3. pdf.benchchem.com \[pdf.benchchem.com\]](#)
- [4. pdf.benchchem.com \[pdf.benchchem.com\]](#)
- [5. reddit.com \[reddit.com\]](#)
- [6. pdf.benchchem.com \[pdf.benchchem.com\]](#)
- [7. pdf.benchchem.com \[pdf.benchchem.com\]](#)
- [8. Yoneda Labs \[yonedalabs.com\]](#)
- [9. pdf.benchchem.com \[pdf.benchchem.com\]](#)
- [10. Suzuki reaction - Wikipedia \[en.wikipedia.org\]](#)
- [11. Suzuki Coupling \[organic-chemistry.org\]](#)
- [12. researchgate.net \[researchgate.net\]](#)
- [13. Solvent Effects on the Selectivity of Palladium-Catalyzed Suzuki-Miyaura Couplings - PMC \[pmc.ncbi.nlm.nih.gov\]](#)
- [14. Suzuki Coupling: Mechanism & Examples | NROChemistry \[nrochemistry.com\]](#)
- [15. researchgate.net \[researchgate.net\]](#)
- [16. chem.libretexts.org \[chem.libretexts.org\]](#)
- [17. pdf.benchchem.com \[pdf.benchchem.com\]](#)
- [18. A General and Efficient Method for the Suzuki-Miyaura Coupling of 2-Pyridyl Nucleophiles - PMC \[pmc.ncbi.nlm.nih.gov\]](#)
- To cite this document: BenchChem. [Technical Support Center: Optimizing Suzuki Coupling of Bromopyridines]. BenchChem, [2026]. [Online PDF]. Available at: [\[https://www.benchchem.com/product/b1280465/docs#technical-support-center-optimizing-suzuki-coupling-of-bromopyridines\]](https://www.benchchem.com/product/b1280465/docs#technical-support-center-optimizing-suzuki-coupling-of-bromopyridines)

Disclaimer & Data Validity:

The information provided in this document is for Research Use Only (RUO) and is strictly not intended for diagnostic or therapeutic procedures. While BenchChem strives to provide accurate protocols, we make no warranties, express or implied, regarding the fitness of this product for every specific experimental setup.

Technical Support: The protocols provided are for reference purposes. Unsure if this reagent suits your experiment?

Need Industrial/Bulk Grade? [Request Custom Synthesis Quote](#)

BenchChem

Our mission is to be the trusted global source of essential and advanced chemicals, empowering scientists and researchers to drive progress in science and industry.

Contact

Address: 3281 E Guasti Rd
Ontario, CA 91761, United States
Phone: (601) 213-4426
Email: info@benchchem.com

[Contact our Ph.D. Support Team for a compatibility check](#)