

Technical Guide: Differentiating Regioisomers in Pyrazolo[1,5-a]pyridine Synthesis

Author: BenchChem Technical Support Team. **Date:** May 2026

Compound of Interest

Compound Name: *Pyrazolo[1,5-a]pyridin-2-yl-methanol hydrochloride*

CAS No.: *1187932-28-0*

Cat. No.: *B1471018*

[Get Quote](#)

Executive Summary

The pyrazolo[1,5-a]pyridine scaffold is a bioisostere of indole and a privileged structure in kinase inhibitors (e.g., substituted analogs targeting Trk, p38, and ERK). However, its synthesis and subsequent functionalization are plagued by regiochemical ambiguity.

This guide addresses the two primary sources of regioisomeric confusion:

- **Cyclization Regioisomers (C2 vs. C3):** Arising during the [3+2] cycloaddition of -aminopyridines with unsymmetrical alkynes.
- **Functionalization Regioisomers (C3 vs. C7):** Arising during late-stage C-H activation, where electrophilic and concerted metalation-deprotonation (CMD) mechanisms compete.

We provide a definitive decision matrix for structural assignment using NMR (NOESY/HMBC) and optimized protocols to control regioselectivity.

Part 1: The Regioisomer Challenge

Structural Numbering & Ambiguity

Correct assignment relies on understanding the electronic bias of the scaffold.

- Position 7 (H7): The proton adjacent to the bridgehead nitrogen is significantly deshielded (8.5–8.8 ppm) and is the most acidic C-H bond (est. ~28-30).
- Position 3 (C3): The most electron-rich site, prone to electrophilic aromatic substitution ().

The Two Bifurcation Points

The following diagram illustrates where regioisomers typically arise in the workflow.

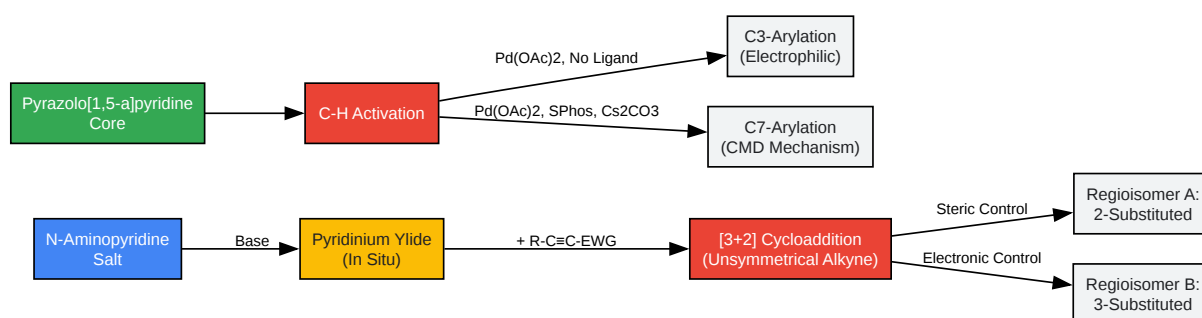

[Click to download full resolution via product page](#)

Figure 1: Synthetic bifurcation points leading to regioisomeric mixtures.

Part 2: Controlling Regioselectivity (Synthesis)

Ring Formation: [3+2] Cycloaddition

The reaction of pyridinium ylides with alkynes is the most common route. Regioselectivity is dictated by the polarization of the dipole (ylide) and the dipolarophile (alkyne).

- The Rule: Electron-withdrawing groups (EWG) on the alkyne typically end up at C3 due to the nucleophilic attack of the ylide carbon on the -carbon of the alkyne.
- The Exception: Steric bulk or specific metal catalysts (e.g., Cu vs. Ag) can invert this, placing the EWG at C2.

Late-Stage Functionalization: C3 vs. C7

Once the ring is formed, differentiating C3 and C7 reactivity is critical.

Parameter	C3-Functionalization	C7-Functionalization
Mechanism	Electrophilic Palladation ()	Concerted Metalation-Deprotonation (CMD)
Key Reagent	Pd(OAc) (Ligand-free)	Pd(OAc) + SPhos (Ligand essential)
Base	Weak/None (or Ag CO)	Strong/Bulky (Cs CO)
Solvent	Dioxane or DMF	Toluene or Xylene (Non-polar favors CMD)
Selectivity	>20:1 (C3:C7)	>20:1 (C7:C3)

Causality: The C3 position is electronically activated (nucleophilic). The C7 position is sterically accessible and the C-H bond is more acidic, allowing a carbonate base to assist the palladium insertion via a CMD transition state [1].

Part 3: Analytical Differentiation (The "How-To")

Do not rely on 1D NMR alone. Chemical shifts can overlap. The following workflow guarantees structural integrity.

The "Golden Triangle" of Assignment

- Identify H7: Look for a doublet (or broad singlet) at 8.4–8.8 ppm. This is the anchor.
- NOESY (Spatial):
 - C3-Substituted: Strong NOE correlation between the substituent and H4.
 - C2-Substituted: Weak/No NOE between substituent and H4. Strong NOE between substituent and H3 (if H3 is present).
- HMBC (Connectivity): The definitive check involves the bridgehead carbon C3a.

Diagnostic Workflow

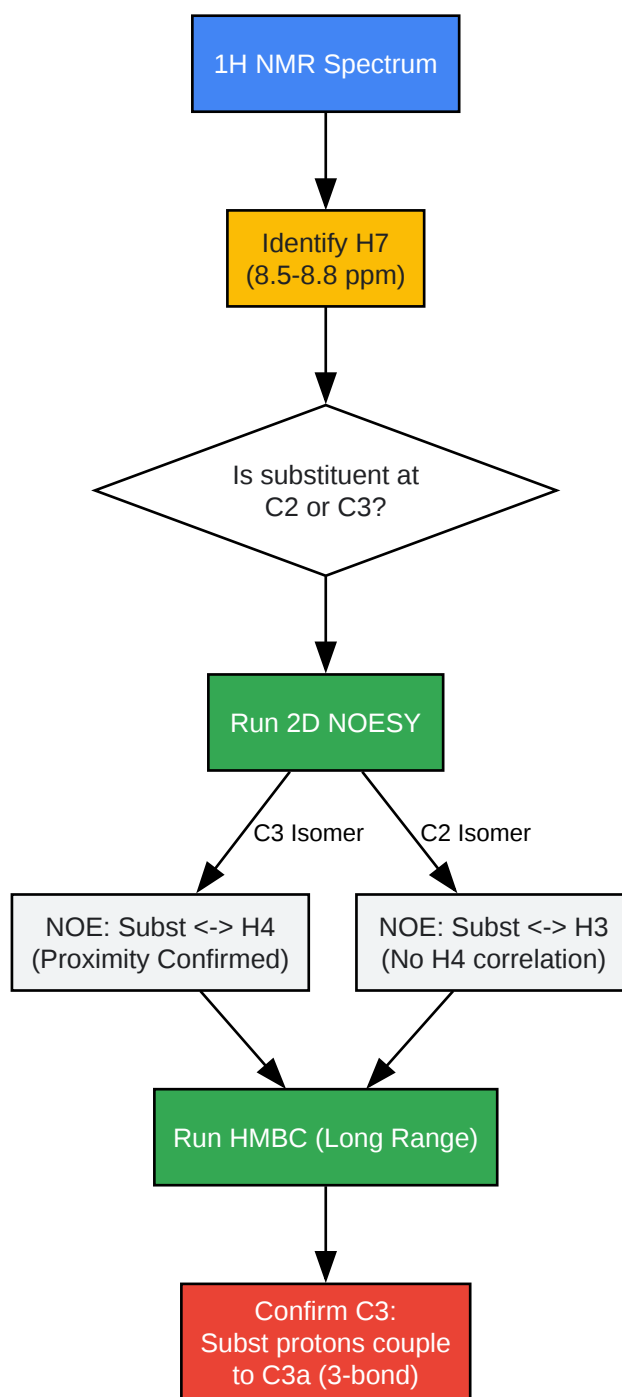

[Click to download full resolution via product page](#)

Figure 2: Analytical decision matrix for regioisomer assignment.

Part 4: Experimental Protocols

Protocol A: Regioselective Synthesis of 3-Carboxylate Isomer

Target: Ethyl pyrazolo[1,5-a]pyridine-3-carboxylate. Method: Oxidative [3+2] Cycloaddition using TEMPO [2].

Reagents:

- -Aminopyridinium iodide (1.0 equiv)
- Ethyl propiolate (1.2 equiv)
- TEMPO (2.0 equiv)
- DBU (2.0 equiv)
- Solvent: CH

CN

Step-by-Step:

- Preparation: Dissolve
-aminopyridinium iodide (1 mmol) in acetonitrile (5 mL) in a round-bottom flask.
- Base Addition: Add DBU (2 mmol) dropwise at 0°C. Stir for 15 min to generate the ylide in situ. The solution typically turns deep yellow/orange.
- Cycloaddition: Add ethyl propiolate (1.2 mmol) followed by TEMPO (2 mmol).
- Reaction: Warm to room temperature and stir for 4 hours under air (balloon). TEMPO acts as the oxidant to aromatize the intermediate dihydropyrazole.
- Workup: Dilute with EtOAc, wash with saturated NH

Cl and brine. Dry over Na

SO

- Purification: Silica gel chromatography (Hexane/EtOAc). The 3-isomer is typically the major product (>90% regioselectivity).

Protocol B: C7-Selective Arylation (C-H Activation)

Target: 7-Phenylpyrazolo[1,5-a]pyridine.[1] Method: Pd-catalyzed C-H activation (Bedford Conditions) [3].

Reagents:

- Pyrazolo[1,5-a]pyridine (1.0 equiv)
- Bromobenzene (1.5 equiv)
- Pd(OAc)
(5 mol%)
- SPhos (10 mol%) - CRITICAL for C7 selectivity
- Cs
CO
(2.0 equiv)
- Solvent: Toluene (anhydrous)

Step-by-Step:

- Setup: In a glovebox or under Ar, combine the scaffold, bromobenzene, Pd(OAc)
, SPhos, and Cs
CO
in a pressure vial.
- Solvent: Add degassed toluene.

- Heating: Seal and heat to 140°C for 16 hours.
- Workup: Filter through Celite. Concentrate.
- Differentiation Check: Analyze crude NMR.
 - C7-Product: The characteristic H7 doublet (~8.5 ppm) will be missing. A new aromatic multiplet appears.
 - C3-Product (Impurity): H7 doublet remains; H3 singlet (~8.0 ppm) disappears.

Part 5: Data Comparison

The following table compares the expected chemical shifts for the parent scaffold versus regioisomers, aiding in quick identification.

Position	Parent Scaffold (ppm)	3-Substituted (EWG)	7-Substituted (Aryl)
H-2	7.95 (d)	8.45 (s) (Deshielded)	7.98 (d)
H-3	6.50 (d)	Absent	6.55 (d)
H-7	8.52 (d)	8.60 (d)	Absent
H-4	7.50 (d)	8.15 (d) (Anisotropic effect)	7.55 (d)
Key NOE	H2	H2	H2
	H3	Subst; H4	H3
		Subst	

Note: Shifts are approximate (in CDCl₃)

) and depend on the specific substituent.

References

- Bedford, R. B., et al. "Palladium-Catalyzed Direct C–H Arylation of Pyrazolo[1,5-a]pyrimidines: Mechanism and Regioselectivity." *Journal of Organic Chemistry*, 2015.
- Adimurthy, S., et al. "Synthesis of Functionalized Pyrazolo[1,5-a]pyridines: [3+2] Cycloaddition of N-Aminopyridines and α,β -Unsaturated Carbonyl Compounds." *Synthesis*, 2017.[2]
- Wu, Y., et al. "Regioselective C-H Functionalization of the Six-Membered Ring of the 6,5-Fused Heterocyclic Systems." *Molecules*, 2021.[3][4]
- Salgado, A., et al. "Differentiation between [1,2,4]triazolo[1,5-a]pyrimidine and [1,2,4]triazolo[4,3-a]pyrimidine regioisomers by 1H-15N HMBC experiments." *Magnetic Resonance in Chemistry*, 2010.[5]

Need Custom Synthesis?

BenchChem offers custom synthesis for rare earth carbides and specific isotopic labeling.

Email: info@benchchem.com or [Request Quote Online](#).

Sources

- 1. Regioselective C(sp²)–H halogenation of pyrazolo[1,5-a]pyrimidines facilitated by hypervalent iodine(iii) under aqueous and ambient conditions - PMC [[pmc.ncbi.nlm.nih.gov](https://pubmed.ncbi.nlm.nih.gov)]
- 2. Synthesis of Functionalized Pyrazolo[1,5-a]pyridines: [3+2] Cycloaddition of N-Aminopyridines and α,β -Unsaturated Carbonyl Compounds/Alkenes at Room Temperature [[organic-chemistry.org](https://www.organic-chemistry.org)]
- 3. [mdpi.com](https://www.mdpi.com) [[mdpi.com](https://www.mdpi.com)]
- 4. [mdpi.com](https://www.mdpi.com) [[mdpi.com](https://www.mdpi.com)]
- 5. Differentiation between [1,2,4]triazolo[1,5-a] pyrimidine and [1,2,4]triazolo[4,3-a]-pyrimidine regioisomers by 1H-15N HMBC experiments - PubMed [pubmed.ncbi.nlm.nih.gov]
- To cite this document: BenchChem. [Technical Guide: Differentiating Regioisomers in Pyrazolo[1,5-a]pyridine Synthesis]. BenchChem, [2026]. [Online PDF]. Available at: [<https://www.benchchem.com/product/b1471018/docs#technical-guide-differentiating-regioisomers-in-pyrazolo-1-5-a-pyridine-synthesis>]

Disclaimer & Data Validity:

The information provided in this document is for Research Use Only (RUO) and is strictly not intended for diagnostic or therapeutic procedures. While BenchChem strives to provide accurate protocols, we make no warranties, express or implied, regarding the fitness of this product for every specific experimental setup.

Technical Support: The protocols provided are for reference purposes. Unsure if this reagent suits your experiment?

Need Industrial/Bulk Grade? [Request Custom Synthesis Quote](#)

BenchChem

Our mission is to be the trusted global source of essential and advanced chemicals, empowering scientists and researchers to drive progress in science and industry.

Contact

Address: 3281 E Guasti Rd
Ontario, CA 91761, United States
Phone: (601) 213-4426
Email: info@benchchem.com

[Contact our Ph.D. Support Team for a compatibility check](#)