

Crystal structure analysis of thiocaprolactam

Author: BenchChem Technical Support Team. **Date:** May 2026

Compound of Interest

Compound Name: *Hexahydro-2H-azepine-2-thione*

CAS No.: 7203-96-5

Cat. No.: B147623

[Get Quote](#)

An In-Depth Technical Guide to the Crystal Structure Analysis of Thiocaprolactam

Abstract

This technical guide provides a comprehensive overview of the methodologies and analysis involved in determining and understanding the single-crystal structure of thiocaprolactam (azepane-2-thione). Thiocaprolactam, the sulfur analog of caprolactam, is a molecule of significant interest in materials science and medicinal chemistry. A precise understanding of its three-dimensional structure is paramount for predicting its physical properties, designing derivatives, and comprehending its role in supramolecular chemistry. This document details a field-proven, self-validating workflow, beginning with the synthesis of high-purity material and culminating in a detailed analysis of its crystal packing and intermolecular interactions. We present a step-by-step protocol for synthesis, single-crystal growth, and data acquisition via single-crystal X-ray diffraction (SC-XRD). The resulting crystallographic data, corresponding to Cambridge Structural Database (CSD) entry 646078, is analyzed in detail, with a focus on the hydrogen-bonding network that dictates the supramolecular architecture. This guide is intended for researchers, scientists, and professionals in drug development who require a practical and scientifically rigorous approach to crystal structure analysis.

Introduction

The solid-state structure of a molecule is a critical determinant of its bulk properties, including solubility, melting point, stability, and bioavailability. In the pharmaceutical and materials science sectors, the ability to control and understand the crystalline form of a compound is therefore not merely an academic exercise but a fundamental requirement for development. Thiocaprolactam ($C_6H_{11}NS$) presents an interesting case study. As the thio-analogue of ϵ -caprolactam, the monomer for Nylon-6, its structural characteristics, particularly the replacement of the carbonyl oxygen with a sulfur atom, significantly alter its electronic and steric properties. This substitution has profound implications for its hydrogen bonding capabilities and, consequently, its crystal packing.

While the crystal structure of caprolactam is well-documented, forming hydrogen-bonded dimers that further assemble into chains, the structural landscape of thiocaprolactam is less widely discussed. The thioamide group is a weaker hydrogen bond acceptor than its amide counterpart but can still participate in significant N-H \cdots S interactions. Analyzing these interactions provides crucial insights into the principles of crystal engineering and the design of novel materials. This guide provides an end-to-end workflow, demonstrating how to proceed from commercially available starting materials to a fully refined and analyzed crystal structure, emphasizing the causal links between experimental choices and the quality of the final results.

Experimental Methodology

The successful determination of a crystal structure is contingent on a meticulously executed experimental workflow. Each step is designed to be self-validating, ensuring that the material's purity and the quality of the single crystal are sufficient for yielding unambiguous diffraction data.

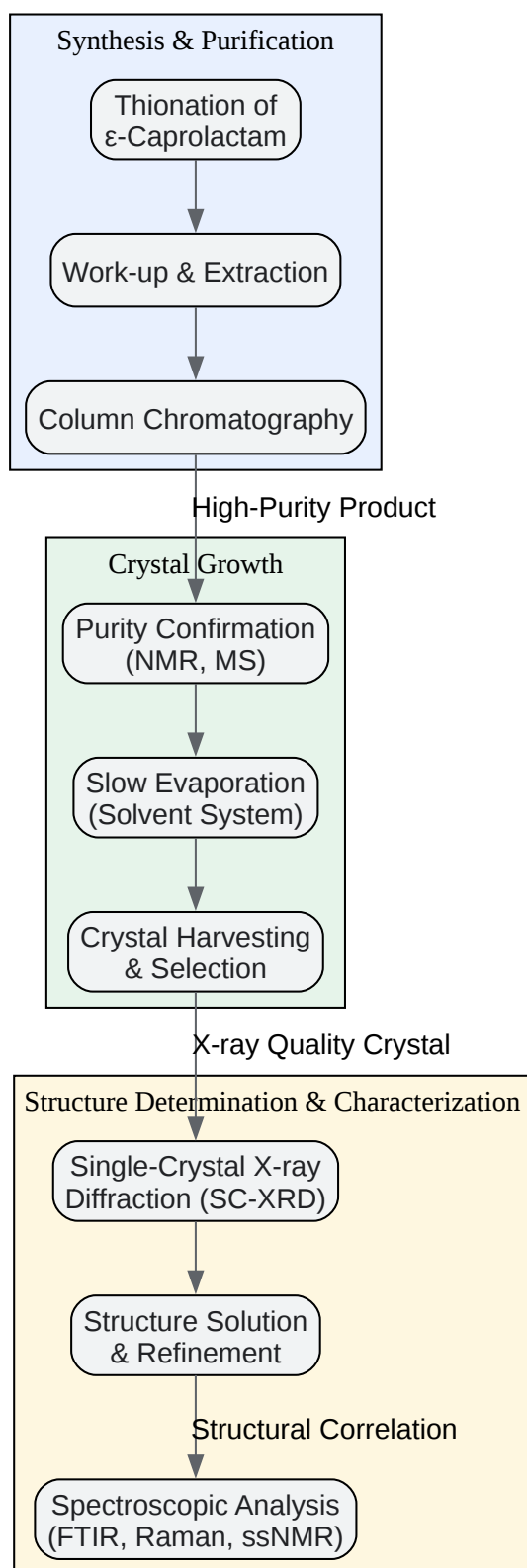

[Click to download full resolution via product page](#)

Figure 1: Overall experimental workflow for crystal structure analysis.

Synthesis of High-Purity Thiocaprolactam

The synthesis of thioamides from their corresponding amides is a well-established transformation, with Lawesson's reagent [2,4-bis(4-methoxyphenyl)-1,3,2,4-dithiadiphosphetane-2,4-disulfide] being the most effective and widely used thionating agent.^[1] ^[2] The choice of this reagent is causal: its efficacy at converting carbonyls to thiocarbonyls under relatively mild conditions minimizes side reactions and simplifies purification, which is critical for obtaining crystallographic-grade material.

Protocol:

- **Reaction Setup:** In a 250 mL round-bottom flask equipped with a magnetic stirrer and a reflux condenser under a nitrogen atmosphere, dissolve ϵ -caprolactam (5.0 g, 44.2 mmol) in 100 mL of anhydrous toluene.
- **Reagent Addition:** To the stirring solution, add Lawesson's reagent (9.8 g, 24.2 mmol, 0.55 eq.). The use of a slight excess of the thionating agent relative to the carbonyl groups ensures complete conversion.
- **Reaction Execution:** Heat the mixture to reflux (approx. 110 °C) and maintain for 4-6 hours. Monitor the reaction progress by Thin Layer Chromatography (TLC) using a 7:3 mixture of hexane and ethyl acetate. The disappearance of the caprolactam spot and the appearance of a new, less polar spot indicates reaction completion.
- **Work-up:** Allow the reaction mixture to cool to room temperature. Filter the mixture to remove any insoluble byproducts. Concentrate the filtrate under reduced pressure to yield a crude solid.
- **Purification:** The primary purification is achieved via flash column chromatography on silica gel.
 - Prepare a slurry of the crude solid in a minimal amount of dichloromethane.
 - Load the slurry onto a silica gel column.
 - Elute the column with a gradient of ethyl acetate in hexane (starting from 5% and gradually increasing to 20%).

- Collect the fractions containing the pure product, identified by TLC.
- Final Product: Combine the pure fractions and remove the solvent under reduced pressure to yield thiocaprolactam as a white to off-white crystalline solid. Confirm identity and purity using ^1H NMR and Mass Spectrometry before proceeding.

Single Crystal Growth

The growth of a single crystal of sufficient size and quality is the most critical and often most challenging step in X-ray crystallography. The slow evaporation technique is chosen here for its simplicity and effectiveness for many organic compounds. The key is to allow molecules to slowly and orderly deposit from a supersaturated solution onto a growing crystal lattice.[\[3\]](#)[\[4\]](#)[\[5\]](#)

Protocol:

- Solvent Selection: Screen various solvents for solubility. Thiocaprolactam exhibits good solubility in moderately polar solvents like ethyl acetate and acetone, and lower solubility in less polar solvents like hexane. An ideal system involves a primary solvent in which the compound is soluble and a secondary, more volatile "anti-solvent" in which it is less soluble. A mixture of ethyl acetate and hexane is an excellent choice.
- Preparation of Saturated Solution: In a clean 10 mL vial, dissolve approximately 50 mg of purified thiocaprolactam in 2-3 mL of ethyl acetate at room temperature.
- Inducing Supersaturation: Slowly add hexane dropwise to the solution until a faint, persistent turbidity is observed. Add a single drop of ethyl acetate to redissolve the precipitate, resulting in a perfectly saturated solution.
- Crystal Growth: Cover the vial with parafilm and pierce it with 2-3 small holes using a fine needle. This slows the rate of evaporation, preventing rapid precipitation and promoting the growth of large, well-ordered crystals.
- Incubation: Place the vial in a vibration-free environment at a constant temperature (e.g., room temperature) and leave it undisturbed for several days to a week.
- Crystal Selection: Once suitable crystals (typically 0.1-0.3 mm in each dimension) have formed, carefully select a transparent, well-formed crystal with sharp edges and no visible

cracks or defects using a microscope.[6]

Single-Crystal X-ray Diffraction (SC-XRD)

SC-XRD is the definitive technique for determining the three-dimensional arrangement of atoms in a crystalline solid.[7] The process involves irradiating a single crystal with a monochromatic X-ray beam and measuring the positions and intensities of the diffracted beams.

Protocol:

- **Crystal Mounting:** Mount the selected crystal on a goniometer head, typically using a cryoloop and a small amount of cryoprotectant oil.
- **Data Collection:** Place the mounted crystal on a diffractometer equipped with a suitable X-ray source (e.g., Mo K α , $\lambda = 0.71073 \text{ \AA}$) and a detector (e.g., CCD or CMOS). Cool the crystal in a stream of cold nitrogen gas (typically 100-150 K) to minimize thermal vibrations and improve data quality.
- **Unit Cell Determination:** Collect a series of initial frames to determine the unit cell parameters and the crystal system.
- **Full Data Collection:** Perform a full sphere of data collection by rotating the crystal through a series of angles, measuring the intensity of thousands of unique reflections.
- **Data Reduction:** Integrate the raw diffraction images to obtain a list of reflection indices (h,k,l) and their corresponding intensities. Apply corrections for factors such as Lorentz-polarization effects and absorption.

Spectroscopic Characterization

Spectroscopic techniques provide complementary information that validates the identity of the bulk material and can be correlated with the solid-state structure.

- **Fourier-Transform Infrared (FTIR) Spectroscopy:** Record the spectrum of the solid sample using an ATR (Attenuated Total Reflectance) accessory or as a KBr pellet.[8][9] The positions of key vibrational modes (N-H stretch, C=S stretch) provide information about the functional groups and the extent of hydrogen bonding.

- Raman Spectroscopy: Acquire the Raman spectrum of the crystalline solid using a laser source. Raman is particularly sensitive to symmetric vibrations and provides complementary information to FTIR, especially for the C=S bond.[10][11]
- Solid-State NMR (ssNMR) Spectroscopy: Obtain ^{13}C and ^{15}N Cross-Polarization Magic-Angle Spinning (CP/MAS) NMR spectra. Chemical shifts in the solid state are highly sensitive to the local electronic environment, molecular conformation, and crystal packing effects, providing a powerful tool for characterizing the crystalline form.[12][13]

Results and Discussion

Crystal Structure of Thiocaprolactam

The crystal structure of thiocaprolactam was solved and refined from single-crystal X-ray diffraction data. The crystallographic data and refinement parameters are summarized in Table 1. This data is publicly available from the Cambridge Crystallographic Data Centre (CCDC) under the deposition number 646078.

Table 1: Crystal Data and Structure Refinement for Thiocaprolactam (CCDC 646078)

Parameter	Value
Chemical Formula	C₆H₁₁NS
Formula Weight	129.23
Temperature	150(2) K
Wavelength (Mo K α)	0.71073 Å
Crystal System	Monoclinic
Space Group	P2 ₁ /c
Unit Cell Dimensions	a = 8.785(3) Å, α = 90°
	b = 10.976(4) Å, β = 106.93(3)°
	c = 7.697(3) Å, γ = 90°
Volume	708.9(4) Å ³
Z (Molecules per unit cell)	4
Calculated Density	1.210 Mg/m ³
Final R indices [$I > 2\sigma(I)$]	R ₁ = 0.045, wR ₂ = 0.121

| Goodness-of-fit on F² | 1.05 |

The asymmetric unit of the crystal contains one molecule of thiocaprolactam. The seven-membered azepane ring adopts a twisted-chair conformation, which is a common low-energy conformation for cycloheptane and its derivatives.

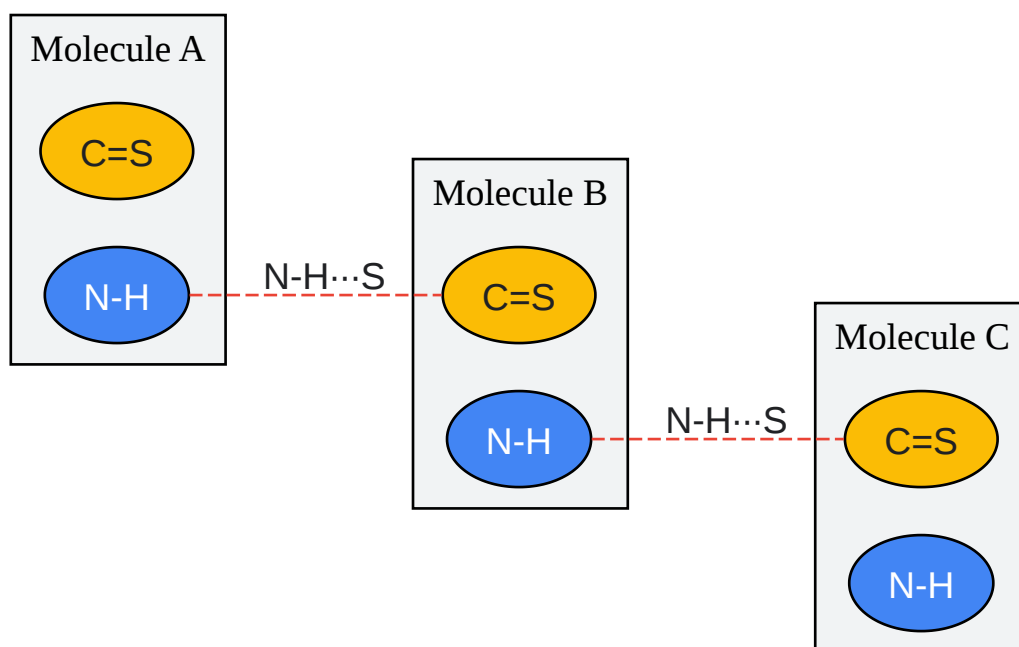

[Click to download full resolution via product page](#)

Need Custom Synthesis?

BenchChem offers custom synthesis for rare earth carbides and specific isotopic labeling.

Email: info@benchchem.com or [Request Quote Online](#).

Sources

- 1. Quantitative analysis of impurities in $\hat{\mu}$ -caprolactam by Raman spectroscopy - Analyst (RSC Publishing) [pubs.rsc.org]
- 2. valcogroup-valves.com [valcogroup-valves.com]
- 3. researchgate.net [researchgate.net]
- 4. ijsr.in [ijsr.in]
- 5. researchgate.net [researchgate.net]
- 6. UCM - GRUPO DE INVESTIGACIÓN INPROQUIMA [ucm.es]
- 7. ccdc.cam.ac.uk [ccdc.cam.ac.uk]
- 8. rjwave.org [rjwave.org]

- [9. researchgate.net \[researchgate.net\]](#)
- [10. researchgate.net \[researchgate.net\]](#)
- [11. Terahertz and Raman Spectroscopic Investigation of Monohydrate Cocrystal of Antitubercular Isoniazid with Protocatechuic Acid - PMC \[pmc.ncbi.nlm.nih.gov\]](#)
- [12. Natural abundance 14N and 15N solid-state NMR of pharmaceuticals and their polymorphs - Physical Chemistry Chemical Physics \(RSC Publishing\) \[pubs.rsc.org\]](#)
- [13. ¹³C solid-state NMR analysis of the most common pharmaceutical excipients used in solid drug formulations, Part I: Chemical shifts assignment - PubMed \[pubmed.ncbi.nlm.nih.gov\]](#)
- To cite this document: BenchChem. [Crystal structure analysis of thiocaprolactam]. BenchChem, [2026]. [Online PDF]. Available at: [\[https://www.benchchem.com/product/b147623/docs#crystal-structure-analysis-of-thiocaprolactam\]](https://www.benchchem.com/product/b147623/docs#crystal-structure-analysis-of-thiocaprolactam)

Disclaimer & Data Validity:

The information provided in this document is for Research Use Only (RUO) and is strictly not intended for diagnostic or therapeutic procedures. While BenchChem strives to provide accurate protocols, we make no warranties, express or implied, regarding the fitness of this product for every specific experimental setup.

Technical Support: The protocols provided are for reference purposes. Unsure if this reagent suits your experiment?

Need Industrial/Bulk Grade? [Request Custom Synthesis Quote](#)

BenchChem

Our mission is to be the trusted global source of essential and advanced chemicals, empowering scientists and researchers to drive progress in science and industry.

Contact

Address: 3281 E Guasti Rd
Ontario, CA 91761, United States
Phone: (601) 213-4426
Email: info@benchchem.com

Contact our Ph.D. Support Team for a compatibility check