

Spectroscopic Characterization of 9-(3-Chlorophenyl)-9H-fluorene: A Technical Guide

Author: BenchChem Technical Support Team. **Date:** April 2026

Compound of Interest

Compound Name: 9-(3-Chlorophenyl)-9H-fluorene

CAS No.: 32377-11-0

Cat. No.: B14692685

[Get Quote](#)

This technical guide provides a detailed analysis of the expected spectroscopic data for the compound **9-(3-Chlorophenyl)-9H-fluorene**. Designed for researchers, scientists, and professionals in drug development, this document synthesizes theoretical predictions with established principles of spectroscopic analysis. While experimental data for this specific molecule is not readily available in the public domain, this guide constructs a robust, predicted spectroscopic profile based on the analysis of its constituent chemical moieties and data from structurally related compounds.

Introduction

9-(3-Chlorophenyl)-9H-fluorene is a derivative of fluorene, a polycyclic aromatic hydrocarbon. The introduction of a 3-chlorophenyl group at the 9-position significantly influences the molecule's electronic and steric properties, which in turn are reflected in its spectroscopic signatures. Understanding these signatures is paramount for the unambiguous identification and characterization of this compound in various research and development settings. This guide will delve into the predicted Nuclear Magnetic Resonance (NMR), Infrared (IR), and Mass Spectrometry (MS) data for **9-(3-Chlorophenyl)-9H-fluorene**, providing a foundational reference for its analysis.

Molecular Structure and Predicted Spectroscopic Behavior

The structure of **9-(3-Chlorophenyl)-9H-fluorene**, with its distinct fluorenyl and 3-chlorophenyl components, dictates its interaction with different forms of electromagnetic radiation and its behavior under mass spectrometric conditions. The following sections will break down the predicted spectroscopic data based on this structure.

Caption: Molecular structure of **9-(3-Chlorophenyl)-9H-fluorene**.

Nuclear Magnetic Resonance (NMR) Spectroscopy

NMR spectroscopy is a powerful tool for elucidating the carbon-hydrogen framework of a molecule.

¹H NMR Spectroscopy

The proton NMR spectrum of **9-(3-Chlorophenyl)-9H-fluorene** is expected to show distinct signals for the protons of the fluorene and the 3-chlorophenyl rings.

- **Fluorene Protons:** The eight aromatic protons of the fluorene moiety will likely appear as a complex series of multiplets in the aromatic region (typically δ 7.0-8.0 ppm). The protons at positions 1, 8, 4, and 5 are expected to be the most deshielded due to their proximity to the neighboring aromatic ring.
- **9-H Proton:** The single proton at the 9-position is a methine proton and is expected to appear as a singlet. Its chemical shift will be significantly influenced by the adjacent aromatic rings and the chlorophenyl substituent, likely falling in the range of δ 5.0-6.0 ppm.
- **3-Chlorophenyl Protons:** The four protons of the 3-chlorophenyl group will exhibit a distinct splitting pattern. The proton at the 2'-position will likely be a singlet or a narrow triplet. The proton at the 6'-position will be a doublet of doublets, and the protons at the 4'- and 5'-positions will also show complex splitting patterns.

Table 1: Predicted ¹H NMR Chemical Shifts for **9-(3-Chlorophenyl)-9H-fluorene**

Proton Assignment	Predicted Chemical Shift (δ , ppm)	Multiplicity
Fluorene aromatic H	7.20 - 7.90	m
9-H	5.50 - 5.80	s
2'-H (Chlorophenyl)	\sim 7.30	s or t (narrow)
4'-H (Chlorophenyl)	\sim 7.25	m
5'-H (Chlorophenyl)	\sim 7.15	m
6'-H (Chlorophenyl)	\sim 7.10	dd

¹³C NMR Spectroscopy

The carbon NMR spectrum will provide information on the number and electronic environment of the carbon atoms.

- **Fluorene Carbons:** The fluorene skeleton will show multiple signals in the aromatic region (δ 120-150 ppm). The quaternary carbons at the bridgehead positions (4a, 4b, 8a, 9a) will have distinct chemical shifts.
- **9-C Carbon:** The methine carbon at the 9-position is expected to have a chemical shift in the range of δ 50-60 ppm.
- **3-Chlorophenyl Carbons:** The 3-chlorophenyl group will show six distinct signals for its carbon atoms. The carbon atom bearing the chlorine (C-3') will be significantly influenced by the electronegative halogen.

Table 2: Predicted ¹³C NMR Chemical Shifts for **9-(3-Chlorophenyl)-9H-fluorene**

Carbon Assignment	Predicted Chemical Shift (δ , ppm)
Fluorene aromatic C	120 - 145
Fluorene quaternary C	140 - 150
9-C	50 - 60
1'-C (Chlorophenyl)	~145
2'-C (Chlorophenyl)	~128
3'-C (Chlorophenyl)	~134
4'-C (Chlorophenyl)	~130
5'-C (Chlorophenyl)	~126
6'-C (Chlorophenyl)	~127

Infrared (IR) Spectroscopy

IR spectroscopy provides information about the functional groups present in a molecule. The IR spectrum of **9-(3-Chlorophenyl)-9H-fluorene** is expected to be dominated by absorptions from the aromatic rings and the C-Cl bond.

- **Aromatic C-H Stretch:** Strong to medium bands are expected in the region of 3000-3100 cm^{-1} corresponding to the stretching vibrations of the aromatic C-H bonds.
- **Aromatic C=C Stretch:** Several sharp, medium to strong bands will appear in the 1450-1600 cm^{-1} region due to the carbon-carbon stretching vibrations within the aromatic rings.
- **C-H Bending:** Out-of-plane C-H bending vibrations will give rise to strong absorptions in the fingerprint region (650-900 cm^{-1}), which can be diagnostic for the substitution patterns of the aromatic rings.
- **C-Cl Stretch:** A medium to strong absorption band corresponding to the C-Cl stretching vibration is expected in the range of 600-800 cm^{-1} .

Table 3: Predicted IR Absorption Bands for **9-(3-Chlorophenyl)-9H-fluorene**

Vibrational Mode	Predicted Frequency (cm ⁻¹)	Intensity
Aromatic C-H Stretch	3000 - 3100	Medium
C-H Stretch (9-H)	~2900	Weak
Aromatic C=C Stretch	1450 - 1600	Medium to Strong
C-H Bending (out-of-plane)	650 - 900	Strong
C-Cl Stretch	600 - 800	Medium to Strong

Mass Spectrometry (MS)

Mass spectrometry provides information about the molecular weight and fragmentation pattern of a molecule. For **9-(3-Chlorophenyl)-9H-fluorene** (C₁₉H₁₃Cl), the expected molecular weight is approximately 276.7 g/mol .

- **Molecular Ion Peak (M⁺):** The mass spectrum should show a prominent molecular ion peak at m/z 276. Due to the presence of the chlorine isotope ³⁷Cl, an M+2 peak at m/z 278 with an intensity of approximately one-third of the M⁺ peak is expected.
- **Fragmentation Pattern:** The fragmentation of the molecular ion is likely to proceed through the loss of the chlorine atom or the chlorophenyl group.
 - [M-Cl]⁺: A significant peak at m/z 241, corresponding to the loss of a chlorine radical.
 - [M-C₆H₄Cl]⁺: A peak at m/z 165, corresponding to the fluorenyl cation, which is expected to be very stable and therefore a major fragment.
 - [C₆H₄Cl]⁺: A peak at m/z 111, corresponding to the chlorophenyl cation.

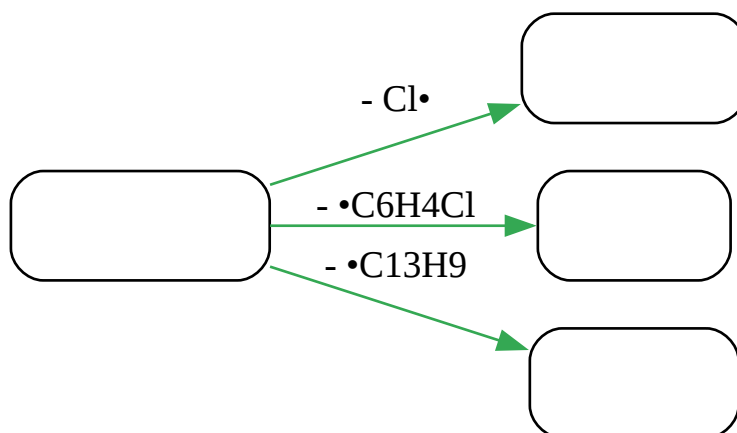

[Click to download full resolution via product page](#)

Caption: Predicted major fragmentation pathways for **9-(3-Chlorophenyl)-9H-fluorene**.

Experimental Protocols

The following are generalized protocols for obtaining spectroscopic data for a solid organic compound like **9-(3-Chlorophenyl)-9H-fluorene**.

NMR Spectroscopy Acquisition

- **Sample Preparation:** Dissolve approximately 5-10 mg of the compound in 0.5-0.7 mL of a deuterated solvent (e.g., CDCl_3 , DMSO-d_6) in a standard 5 mm NMR tube. Ensure the sample is fully dissolved.
- **Instrument Setup:** Place the NMR tube in the spectrometer. Tune and shim the instrument to optimize the magnetic field homogeneity.
- **^1H NMR Acquisition:** Acquire the ^1H NMR spectrum using a standard pulse sequence. Typical parameters include a $30\text{-}45^\circ$ pulse angle, a relaxation delay of 1-2 seconds, and an appropriate number of scans to achieve a good signal-to-noise ratio.
- **^{13}C NMR Acquisition:** Acquire the ^{13}C NMR spectrum using a proton-decoupled pulse sequence. A larger number of scans and a longer relaxation delay may be necessary due to the lower natural abundance and longer relaxation times of the ^{13}C nucleus.

- **Data Processing:** Process the acquired free induction decays (FIDs) by applying Fourier transformation, phase correction, and baseline correction. Calibrate the chemical shift scale using the residual solvent peak or an internal standard (e.g., TMS).

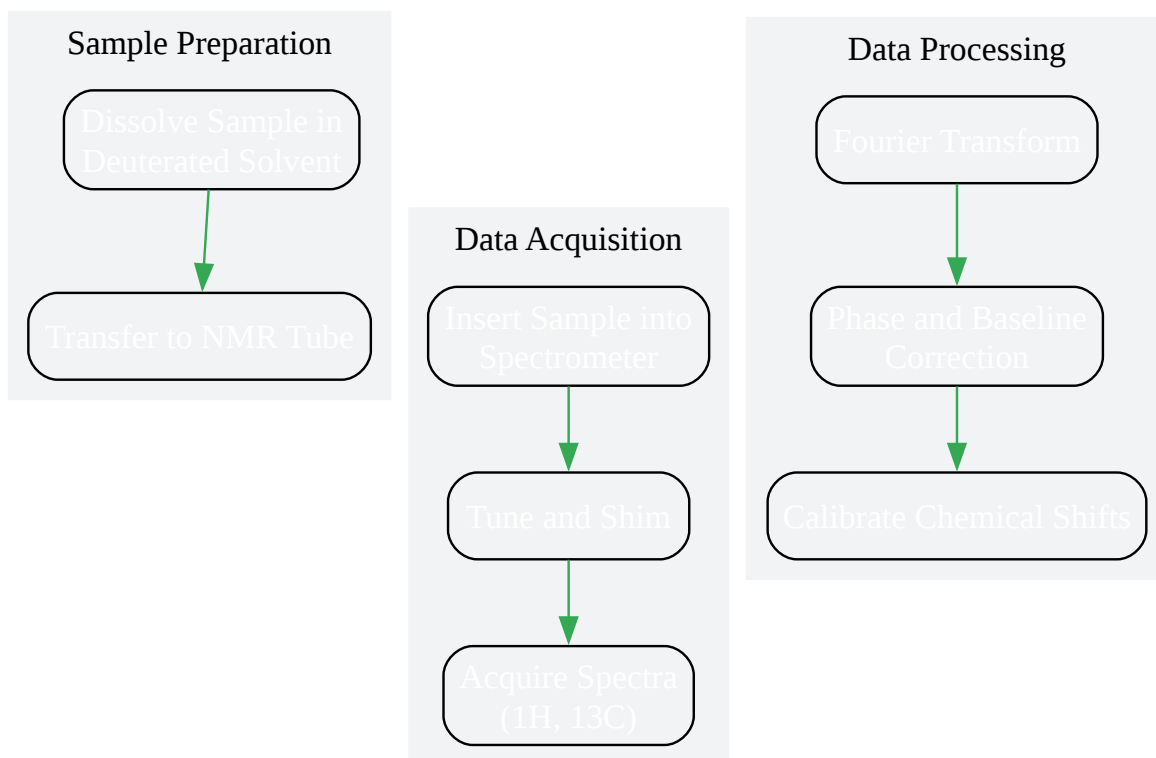

[Click to download full resolution via product page](#)

Caption: General workflow for NMR data acquisition and processing.

IR Spectroscopy Acquisition (ATR-FTIR)

- **Instrument Preparation:** Ensure the Attenuated Total Reflectance (ATR) crystal is clean. Record a background spectrum.
- **Sample Application:** Place a small amount of the solid sample directly onto the ATR crystal and apply pressure to ensure good contact.
- **Spectrum Acquisition:** Acquire the IR spectrum. Typically, 16 to 32 scans are co-added to improve the signal-to-noise ratio.

- **Data Processing:** The acquired spectrum is automatically ratioed against the background spectrum to produce the final absorbance or transmittance spectrum.

Mass Spectrometry Acquisition (Electron Ionization)

- **Sample Introduction:** Introduce a small amount of the sample into the mass spectrometer, typically via a direct insertion probe for solid samples.
- **Ionization:** Volatilize the sample by heating the probe, and ionize the gaseous molecules using a high-energy electron beam (typically 70 eV).
- **Mass Analysis:** Separate the resulting ions based on their mass-to-charge ratio (m/z) using a mass analyzer (e.g., quadrupole, time-of-flight).
- **Detection:** Detect the ions and generate the mass spectrum.

Conclusion

This technical guide provides a comprehensive, albeit predicted, spectroscopic profile of **9-(3-Chlorophenyl)-9H-fluorene**. The presented NMR, IR, and MS data are based on sound spectroscopic principles and analysis of related chemical structures. This information serves as a valuable resource for the identification and characterization of this compound in a laboratory setting. Experimental verification of these predictions will be crucial for the definitive structural elucidation of **9-(3-Chlorophenyl)-9H-fluorene**.

References

Due to the predictive nature of this guide, direct experimental references for **9-(3-Chlorophenyl)-9H-fluorene** are not available. The following are general, authoritative sources for spectroscopic interpretation.

- Silverstein, R. M., Webster, F. X., Kiemle, D. J., & Bryce, D. L. (2014). Spectrometric Identification of Organic Compounds. John Wiley & Sons. [[Link](#)]
- Pavia, D. L., Lampman, G. M., Kriz, G. S., & Vyvyan, J. R. (2014). Introduction to Spectroscopy. Cengage Learning. [[Link](#)]
- NIST Chemistry WebBook. National Institute of Standards and Technology. [[Link](#)][1][2]

Need Custom Synthesis?

BenchChem offers custom synthesis for rare earth carbides and specific isotopic labeling.

Email: info@benchchem.com or [Request Quote Online](#).

Sources

- 1. Fluorene, 9-chloro- [webbook.nist.gov]
- 2. 9H-Fluoren-9-one [webbook.nist.gov]
- To cite this document: BenchChem. [Spectroscopic Characterization of 9-(3-Chlorophenyl)-9H-fluorene: A Technical Guide]. BenchChem, [2026]. [Online PDF]. Available at: [<https://www.benchchem.com/product/b14692685/docs#spectroscopic-characterization-of-9-3-chlorophenyl-9h-fluorene-a-technical-guide>]

Disclaimer & Data Validity:

The information provided in this document is for Research Use Only (RUO) and is strictly not intended for diagnostic or therapeutic procedures. While BenchChem strives to provide accurate protocols, we make no warranties, express or implied, regarding the fitness of this product for every specific experimental setup.

Technical Support: The protocols provided are for reference purposes. Unsure if this reagent suits your experiment?

Need Industrial/Bulk Grade? [Request Custom Synthesis Quote](#)

BenchChem

Our mission is to be the trusted global source of essential and advanced chemicals, empowering scientists and researchers to drive progress in science and industry.

Contact

Address: 3281 E Guasti Rd

Ontario, CA 91761, United States

Phone: (601) 213-4426

Email: info@benchchem.com

Contact our Ph.D. Support Team for a compatibility check