

# minimizing side reactions during indole-azetidine amide coupling

**Author:** BenchChem Technical Support Team. **Date:** April 2026

## Compound of Interest

Compound Name: 1-(1H-indole-6-carbonyl)azetidin-3-ol  
CAS No.: 1338965-30-2  
Cat. No.: B1469081

[Get Quote](#)

## Technical Support Center: Indole-Azetidine Amide Coupling

Welcome to the technical support guide for navigating the complexities of indole-azetidine amide coupling. This resource is designed for researchers, medicinal chemists, and process development scientists who encounter challenges with this specific, yet increasingly important, synthetic transformation. The unique electronic properties of indoles and the inherent ring strain of azetidines create a landscape ripe for side reactions. This guide provides in-depth, mechanistically grounded solutions to help you optimize your reaction outcomes.

### Part 1: Frequently Asked Questions (FAQs)

This section addresses the most common initial queries and provides rapid, actionable advice.

Q1: My indole-azetidine amide coupling is failing or giving very low yields. What are the primary suspects?

Low or no yield is typically traced back to one of three core issues:

- **Azetidine Ring Instability:** Azetidines possess significant ring strain (approx. 25.4 kcal/mol), making them susceptible to decomposition or ring-opening under harsh conditions.[1][2][3] This is the most frequent cause of failure.
- **Low Nucleophilicity of the Indole Nitrogen:** The indole N-H is weakly acidic and not strongly nucleophilic, particularly when compared to aliphatic amines. Conventional amide coupling conditions may not be sufficient to drive the reaction to completion.
- **Steric Hindrance:** Substituents on the indole ring (especially at the C2 and C7 positions) or on the azetidine ring can sterically impede the approach of the coupling partners.[4][5]

Q2: I'm seeing a complex mixture of byproducts. What are the most common side reactions I should be looking for?

The two most prevalent side reactions in this coupling are:

- **Azetidine Ring-Opening:** Triggered by heat, strong acids/bases, or certain coupling reagents, this leads to the formation of linear, rearranged, or oligomeric byproducts instead of the desired amide.[1][2][6]
- **Competitive C3-Acylation of the Indole:** The C3 position of the indole ring is often more nucleophilic than the N1 position, leading to the formation of a C-C bond instead of the desired N-C amide bond.[7][8][9]

Q3: How do I select the best coupling reagent for this specific transformation?

The choice of coupling reagent is critical. Harsh or highly reactive reagents can promote azetidine decomposition. A systematic approach is recommended:

- **Start Mild:** Uronium/Aminium salt-based reagents like HATU (1-[Bis(dimethylamino)methylene]-1H-1,2,3-triazolo[4,5-b]pyridinium 3-oxid hexafluorophosphate) are often the best starting point. They are highly efficient, have fast kinetics, and are known to minimize epimerization, a key concern for chiral azetidines.[1][10]

- **Avoid Harsh Pre-activation:** Generating highly reactive species like acyl chlorides with thionyl chloride or oxalyl chloride can be effective but often leads to a higher incidence of side reactions, particularly azetidine ring-opening.<sup>[1][11]</sup>
- **Consider Additives Carefully:** While additives like HOBt (Hydroxybenzotriazole) are standard with carbodiimides to reduce epimerization, the reagents based on HOAt (Hydroxyazabenzotriazole), such as HATU, are generally superior for challenging couplings.<sup>[10]</sup>

Q4: Is it necessary to protect the indole nitrogen (N-H) before coupling?

While not always mandatory, N-protection is a powerful strategy to circumvent key side reactions and improve outcomes.

- **To Prevent C3-Acylation:** Protecting the nitrogen completely prevents competitive acylation at the C3 position, simplifying the product mixture.
- **To Enhance Stability:** Electron-withdrawing protecting groups like Boc (tert-butyloxycarbonyl) or SEM (2-(trimethylsilyl)ethoxymethyl) can sometimes stabilize the indole ring to certain reaction conditions.<sup>[12][13][14]</sup> However, the deprotection step adds to the synthetic sequence and must be compatible with the strained azetidine ring.<sup>[13][15]</sup>

## Part 2: In-Depth Troubleshooting Guides

This section provides detailed analysis and protocols for overcoming specific, persistent challenges.

### Guide 1: Combating Azetidine Ring-Opening

The high ring strain of azetidines makes them prone to nucleophilic or acid-catalyzed ring-opening.<sup>[2][3][16]</sup> This is the most critical side reaction to control.

Symptoms:

- Low mass balance in your reaction workup.
- Appearance of multiple new, often more polar, spots on TLC.

- LC-MS data showing masses that do not correspond to the starting materials or the desired product.

## Causality &amp; Mitigation Strategies:

Root Cause	Mechanistic Explanation	Recommended Solution & Protocol
Elevated Temperature	Provides the activation energy to overcome the barrier for ring cleavage.[1]	Maintain low temperature. Start the reaction at 0 °C and allow it to slowly warm to room temperature (20-25 °C). Avoid heating unless absolutely necessary.[1]
Harsh Coupling Reagents	Highly reactive intermediates (e.g., O-acylisoureas from DCC) or acidic additives can catalyze ring-opening.[1]	Use mild, modern coupling reagents. HATU or COMU are preferred as they operate under neutral pH and offer rapid kinetics, minimizing contact time with activated species.[1][10]
Lewis Acid Contamination	Trace Lewis acids from reagents or glassware can coordinate to the azetidine nitrogen, activating the ring for nucleophilic attack.[1][16]	Ensure anhydrous and acid-free conditions. Use freshly distilled solvents and flame-dried glassware. If a Lewis acid is suspected, consider adding a non-nucleophilic scavenger base.
Prolonged Reaction Times	Even under mild conditions, extended exposure can lead to gradual decomposition of the strained ring.[1]	Monitor the reaction closely. Check progress by TLC or LC-MS every 30-60 minutes. Quench the reaction as soon as the limiting reagent is consumed.[1]

The following diagram illustrates the desired N-acylation pathway versus the two major competing side reactions.

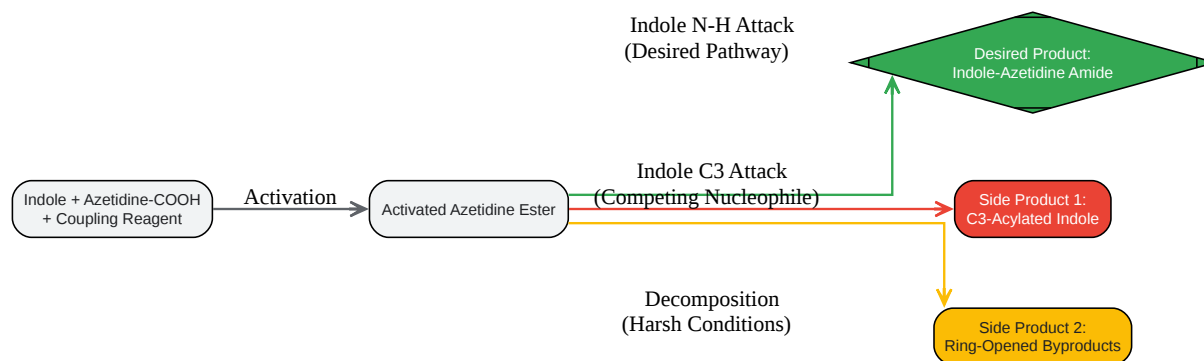

[Click to download full resolution via product page](#)

Caption: Desired N-acylation vs. competing side reactions.

## Guide 2: Ensuring Chemoselectivity (N1 vs. C3 Acylation)

Indoles are ambident nucleophiles. While N-acylation is desired, the electron-rich C3 position often competes, particularly under neutral or acidic conditions.<sup>[7][9]</sup>

Symptoms:

- Isolation of a constitutional isomer of your desired product.
- <sup>1</sup>H NMR shows the disappearance of the C3-H proton signal and persistence of the N-H signal.

Causality & Mitigation Strategies:

Root Cause	Mechanistic Explanation	Recommended Solution & Protocol
Indole Deprotonation State	The neutral indole is more reactive at C3. The indolide anion (formed with a strong base) is exclusively reactive at N1.	Use a suitable base. Adding a non-nucleophilic base like DIPEA (Diisopropylethylamine) or DBU (1,8-Diazabicyclo[5.4.0]undec-7-ene) can help deprotonate the indole N-H, favoring N-acylation. The choice of base and stoichiometry is critical.
Steric Effects	Bulky substituents at the C2 position of the indole can disfavor C3 attack, thereby promoting N-acylation. <sup>[4]</sup>	Leverage substrate bias. If your indole is substituted at C2, C3-acylation is less likely. For unsubstituted indoles, careful condition screening is more critical.
Reaction Conditions	Certain solvents and coupling reagents can favor one pathway over the other.	Screen solvents and bases. Aprotic polar solvents like DMF or NMP are standard. Screen a panel of bases (e.g., DIPEA, DBU, Proton-Sponge®) to find the optimal conditions for N-selectivity.

## Guide 3: Preventing Epimerization of Chiral Azetidines

When using chiral azetidine carboxylic acids (e.g., L-Azetidine-2-carboxylic acid), preserving stereochemical integrity is paramount. Epimerization is a risk, especially with older coupling reagents.<sup>[17]</sup>

Symptoms:

- Diastereomeric products are observed by NMR or chiral chromatography.

- Loss of optical activity in the purified product.

Causality & Mitigation Strategies:

Root Cause	Mechanistic Explanation	Recommended Solution & Protocol
Oxazolone Formation	With carbodiimide reagents (DCC, EDC), the activated acid can cyclize to form a planar, achiral oxazolone intermediate, which is then opened by the amine, leading to racemization.	Use epimerization-suppressing reagents. Reagents like HATU and other HOAt-based couplers are specifically designed to form active esters that react much faster with the amine than they rearrange, significantly minimizing the risk of epimerization.[10]
Azafulvenium Ion Intermediate	For certain substituted azetidines (e.g., spiro-oxindole azetidines), ring-opening to a planar azafulvenium ion followed by re-cyclization can lead to epimerization.[2][6][18]	Maintain mild conditions. This pathway is often promoted by acid or heat. Adhering to the protocols for preventing ring-opening (low temperature, mild reagents) will also suppress this epimerization mechanism.

## Part 3: Recommended Protocols & Workflow

### Optimized Protocol: HATU-Mediated Indole-Azetidine Coupling

This protocol is designed as a robust starting point to maximize yield while minimizing the key side reactions discussed above.

Materials:

- Indole derivative (1.0 eq)
- Azetidine carboxylic acid (1.1 eq)

- HATU (1.2 eq)
- DIPEA (Diisopropylethylamine) (2.5 eq)
- Anhydrous DMF (N,N-Dimethylformamide)

#### Procedure:

- **Preparation:** To a flame-dried round-bottom flask under an inert atmosphere (Argon or Nitrogen), add the azetidine carboxylic acid (1.1 eq) and HATU (1.2 eq).
- **Dissolution:** Add anhydrous DMF to achieve a concentration of approximately 0.1 M with respect to the indole. Stir the mixture at room temperature for 10-15 minutes. This pre-activates the carboxylic acid.
- **Cooling:** Cool the flask to 0 °C in an ice-water bath.
- **Addition of Amine & Base:** In a separate flask, dissolve the indole derivative (1.0 eq) in a minimal amount of anhydrous DMF. Add this solution to the reaction flask, followed by the dropwise addition of DIPEA (2.5 eq).
- **Reaction:** Allow the reaction to stir at 0 °C for 30 minutes, then remove the ice bath and let it warm to room temperature (20-25 °C).
- **Monitoring:** Monitor the reaction progress by LC-MS or TLC every hour. The reaction is often complete within 2-6 hours.
- **Workup:** Once the indole starting material is consumed, quench the reaction by adding saturated aqueous NaHCO<sub>3</sub> solution. Extract the aqueous layer with a suitable organic solvent (e.g., Ethyl Acetate, 3x).
- **Purification:** Combine the organic layers, wash with brine, dry over Na<sub>2</sub>SO<sub>4</sub>, filter, and concentrate under reduced pressure. Purify the crude residue by flash column chromatography.

## Troubleshooting Workflow Diagram

Use this decision tree to diagnose and solve issues with your coupling reaction.

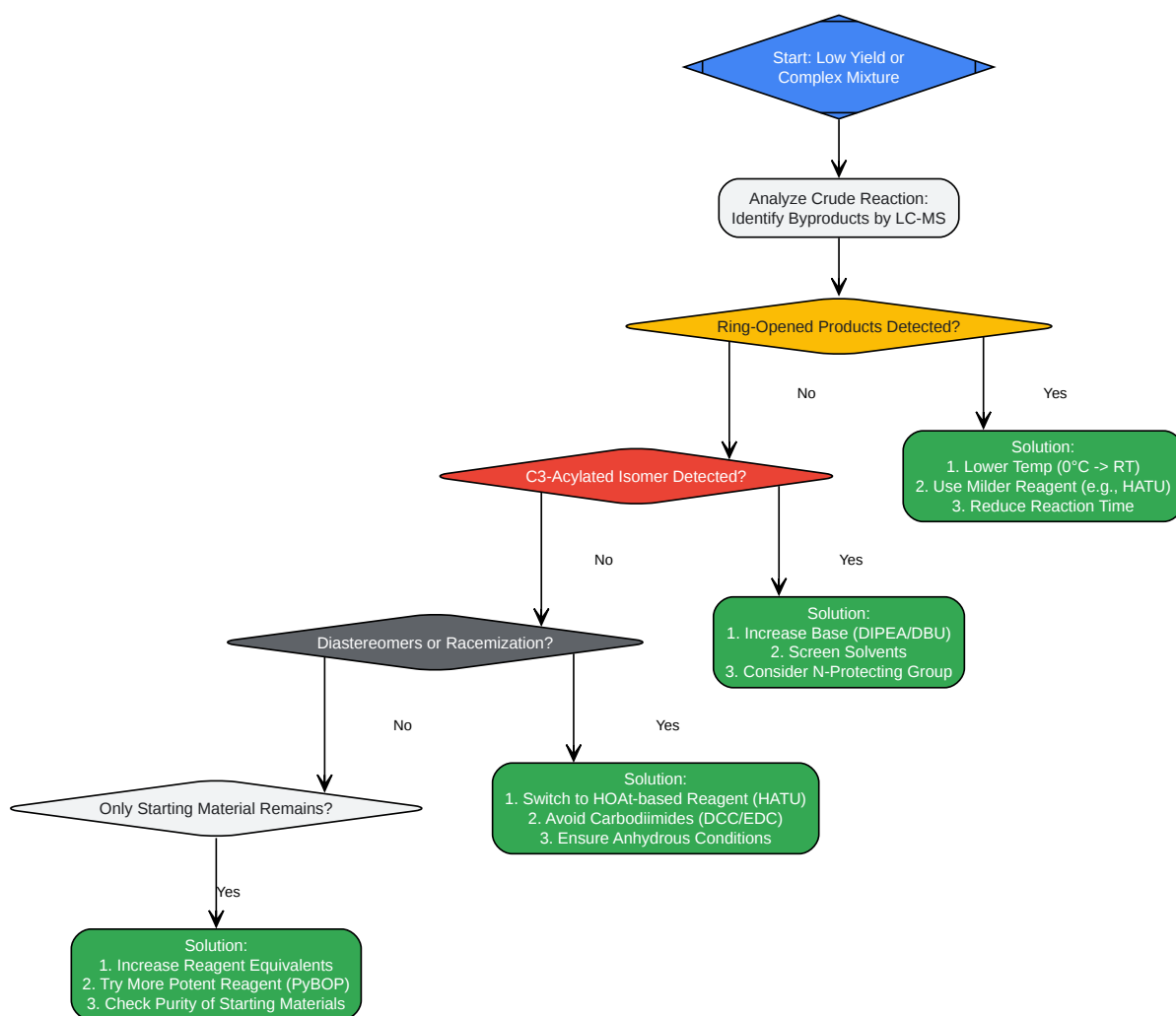

[Click to download full resolution via product page](#)

Caption: A decision tree for troubleshooting common issues.

## References

- BenchChem. (n.d.). How to prevent the ring-opening of azetidines during subsequent reactions. BenchChem Technical Support.
- Sahay, A. K., Begg, C. S., Zhang, X., Bull, J. A., & Spivey, A. C. (2025). Structurally divergent reactivity of 2,2-disubstituted azetidines – mechanistic insights and stereochemical implications of amide coupling and ring expansion to 5,6-dihydro-4H-1,3-oxazines. *Organic Chemistry Frontiers*, 12, 6556-6563. DOI: 10.1039/D5QO00804B.
- Recent Progress Concerning the N-Arylation of Indoles. (n.d.). PMC.
- Intramolecular Ring-Opening Decomposition of Aryl Azetidines. (2021). PMC - NIH.
- BenchChem. (n.d.). Technical Support Center: Azetidine Ring-Opening Reactions. BenchChem.
- Cobalt-catalyzed direct carbonylative 3-acylation of (N–H)Indoles with alkyl halides. (2025). PMC.
- Oxidative organocatalytic chemoselective N-acylation of heterocycles with aromatic and conjugated aldehydes. (2017). *Chemical Communications* (RSC Publishing). DOI: 10.1039/C7CC08672E.
- Chameleon-like Behavior of the Directing Group in the Rh(III)-Catalyzed Regioselective C–H Amidation of Indole: An Experimental and Computational Study. (2019). *ACS Catalysis*.
- Protecting groups for the pyrrole and indole nitrogen atom. The [2-(trimethylsilyl)ethoxy]methyl moiety. Lithiation of 1-[[2-(trimethylsilyl)ethoxy]methyl]pyrrole. (n.d.). *The Journal of Organic Chemistry - ACS Publications*.
- Synthesis of 3-Acylindoles by Palladium-Catalyzed Acylation of Free (N–H) Indoles with Nitriles. (2013). *Organic Letters - ACS Publications*.
- Optimization of amide coupling and ring expansion. (n.d.). ResearchGate.
- Amide bond formation: beyond the myth of coupling reagents. (2008). Luxembourg Bio Technologies.
- Enantioselective Catalytic Synthesis of N-alkylated Indoles. (2020). MDPI.
- Optimizing Peptide Coupling: Key Techniques. (n.d.).
- Recent Advances in the Catalytic Asymmetric Friedel–Crafts Reactions of Indoles. (2022). *ACS Omega*.
- BenchChem. (n.d.). Technical Support Center: N-Protecting Group Removal from Indole Derivatives. BenchChem.
- Synthesis and indole coupling reactions of azetidine and oxetane sulfinic acid salts. (n.d.). White Rose Research Online.
- Photo Click Reaction of Acylsilanes with Indoles. (n.d.). PMC.
- Coupling Reagents. (n.d.). Aapptec Peptides.
- Choosing amide coupling agent. (2023, March 20). Reddit.

- Amino Acid-Protecting Groups. (2019, November 19).
- Amide coupling reaction in medicinal chemistry. Coupling reagents. (n.d.). HepatoChem.
- Direct and Selective 3-Amidation of Indoles Using Electrophilic N-Benzenesulfonyloxyamides. (n.d.). PMC.
- BenchChem. (n.d.). Technical Support Center: Troubleshooting Guide for the Synthesis of Indole Derivatives. BenchChem.
- Mechanism of indole–alkyl amide coupling. (n.d.). ResearchGate.
- Synthesis and indole coupling reactions of azetidine and oxetane sulfinic salts. (n.d.). Chemical Communications (RSC Publishing).
- Highly Efficient Syntheses of Azetidines, Pyrrolidines, and Indolines via Palladium Catalyzed Intramolecular Amination of C(sp<sup>3</sup>)–H and C(sp<sup>2</sup>)–H Bonds at  $\gamma$  and  $\delta$  Positions. (2011). Journal of the American Chemical Society.
- Chemoselective N-acylation of indoles using thioesters as acyl source. (2022). PDF.
- Five Tips and Tricks for Success in Solid Phase Peptide Synthesis. (2023, January 30). Biotage.
- Chemoselective N-acylation of indoles using thioesters as acyl source. (2022). Beilstein Journals.
- Protecting group. (n.d.). Wikipedia.
- Tips and tricks for difficult amide bond formation? (2021, October 20). Reddit.
- Azetidine synthesis. (n.d.). Organic Chemistry Portal.
- Optimized Amide Bond Reaction Using Heterocyclic Compounds and Carboxylic Acid. (2023, February 16).
- BenchChem. (n.d.). Technical Support Center: Azetidine Synthesis Protocols. BenchChem.
- Epimerisation in Peptide Synthesis. (n.d.). PMC - NIH.
- Acid Versus Amide—Facts and Fallacies: A Case Study in Glycomimetic Ligand Design. (n.d.).

### Need Custom Synthesis?

BenchChem offers custom synthesis for rare earth carbides and specific isotopic labeling.

Email: [info@benchchem.com](mailto:info@benchchem.com) or [Request Quote Online](#).

## Sources

- 1. [pdf.benchchem.com](https://pdf.benchchem.com) [[pdf.benchchem.com](https://pdf.benchchem.com)]

- [2. Intramolecular Ring-Opening Decomposition of Aryl Azetidines - PMC \[pmc.ncbi.nlm.nih.gov\]](#)
- [3. benchchem.com \[benchchem.com\]](#)
- [4. Recent Progress Concerning the N-Arylation of Indoles - PMC \[pmc.ncbi.nlm.nih.gov\]](#)
- [5. mdpi.com \[mdpi.com\]](#)
- [6. Structurally divergent reactivity of 2,2-disubstituted azetidines – mechanistic insights and stereochemical implications of amide coupling and ring ex ... - Organic Chemistry Frontiers \(RSC Publishing\) DOI:10.1039/D5QO00804B \[pubs.rsc.org\]](#)
- [7. Oxidative organocatalytic chemoselective N -acylation of heterocycles with aromatic and conjugated aldehydes - Chemical Communications \(RSC Publishing\) DOI:10.1039/C7CC08672E \[pubs.rsc.org\]](#)
- [8. Direct and Selective 3-Amidation of Indoles Using Electrophilic N-Benzenesulfonyloxyamides - PMC \[pmc.ncbi.nlm.nih.gov\]](#)
- [9. BJOC - Chemoselective N-acylation of indoles using thioesters as acyl source \[beilstein-journals.org\]](#)
- [10. peptide.com \[peptide.com\]](#)
- [11. hepatochem.com \[hepatochem.com\]](#)
- [12. pubs.acs.org \[pubs.acs.org\]](#)
- [13. pdf.benchchem.com \[pdf.benchchem.com\]](#)
- [14. pdf.benchchem.com \[pdf.benchchem.com\]](#)
- [15. Protecting group - Wikipedia \[en.wikipedia.org\]](#)
- [16. pdf.benchchem.com \[pdf.benchchem.com\]](#)
- [17. Epimerisation in Peptide Synthesis - PMC \[pmc.ncbi.nlm.nih.gov\]](#)
- [18. researchgate.net \[researchgate.net\]](#)
- To cite this document: BenchChem. [minimizing side reactions during indole-azetidine amide coupling]. BenchChem, [2026]. [Online PDF]. Available at: [\[https://www.benchchem.com/product/b1469081/docs#minimizing-side-reactions-during-indole-azetidine-amide-coupling\]](https://www.benchchem.com/product/b1469081/docs#minimizing-side-reactions-during-indole-azetidine-amide-coupling)

---

**Disclaimer & Data Validity:**

The information provided in this document is for Research Use Only (RUO) and is strictly not intended for diagnostic or therapeutic procedures. While BenchChem strives to provide accurate protocols, we make no warranties, express or implied, regarding the fitness of this product for every specific experimental setup.

**Technical Support:** The protocols provided are for reference purposes. Unsure if this reagent suits your experiment?

**Need Industrial/Bulk Grade?** [Request Custom Synthesis Quote](#)

## BenchChem

Our mission is to be the trusted global source of essential and advanced chemicals, empowering scientists and researchers to drive progress in science and industry.

### Contact

Address: 3281 E Guasti Rd  
Ontario, CA 91761, United States  
Phone: (601) 213-4426  
Email: [info@benchchem.com](mailto:info@benchchem.com)

[Contact our Ph.D. Support Team for a compatibility check](#)