

Potential Therapeutic Applications of Cholan-24-amide Scaffolds

Author: BenchChem Technical Support Team. **Date:** April 2026

Compound of Interest

Compound Name: Cholan-24-amide

CAS No.: 26665-96-3

Cat. No.: B14683680

[Get Quote](#)

Executive Summary

The **Cholan-24-amide** scaffold—derived from the 5

-cholanolic acid backbone common to bile acids like cholic, deoxycholic, and lithocholic acid—represents a privileged structure in medicinal chemistry. Unlike their parent bile acids, which primarily function as metabolic detergents and signaling molecules (via FXR/TGR5), amide derivatives at the C-24 position exhibit distinct pharmacological profiles.

This guide analyzes three high-value therapeutic applications of **cholan-24-amide** derivatives: targeted oncology (specifically N-sulfonyl derivatives), antimicrobial defense (cationic facial amphiphiles), and supramolecular drug delivery (organogelators). We move beyond general descriptions to explore the structure-activity relationships (SAR), mechanistic causality, and validated experimental protocols required for development.

Part 1: Chemical Basis & Structure-Activity Relationship (SAR)

The versatility of the **cholan-24-amide** core lies in its rigid steroid backbone combined with a tunable "tail" at C-24. The facial amphiphilicity—hydrophilic hydroxyl groups on the concave

-face and a hydrophobic convex

-face—is the critical driver for both biological interaction and supramolecular self-assembly.

SAR Visualization

The following diagram illustrates how specific modifications to the **Cholan-24-amide** core dictate therapeutic function.

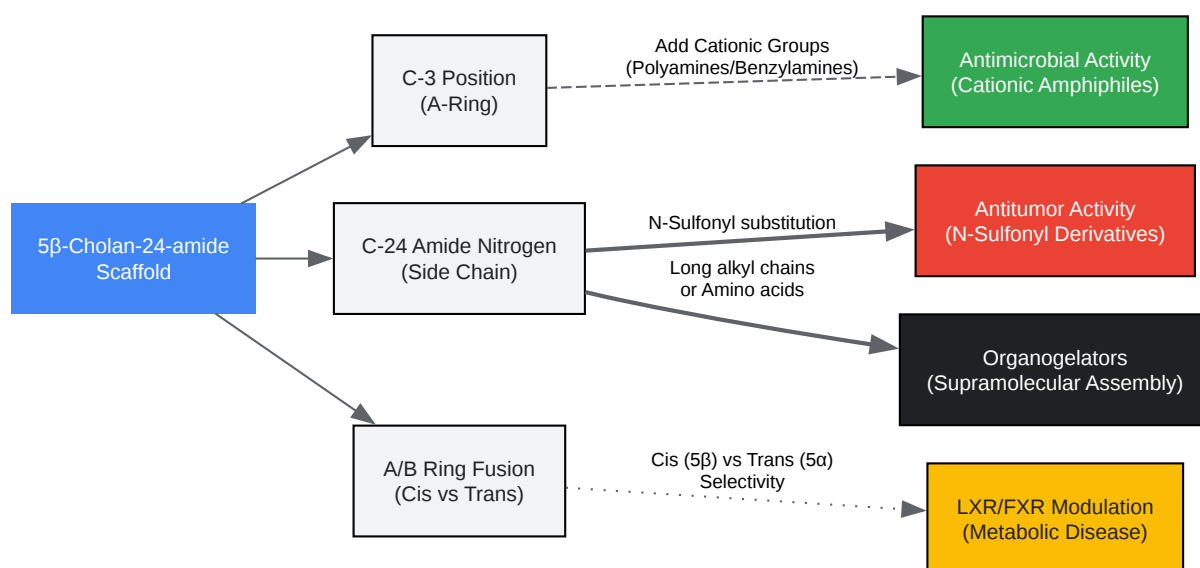

[Click to download full resolution via product page](#)

Figure 1: Structure-Activity Relationship (SAR) map of **Cholan-24-amide** derivatives mapping chemical modifications to therapeutic outcomes.

Part 2: Oncology – N-Sulfonyl Cholan-24-amides

Recent medicinal chemistry campaigns have identified N-sulfonyl-3,7-dioxo-5

-**cholan-24-amides** as potent antitumor agents. Unlike non-specific cytotoxins, these derivatives show selectivity for specific carcinoma lines (e.g., HCT-116, MCF-7) over normal

fibroblasts.

Mechanism of Action

The introduction of an electron-withdrawing sulfonyl group at the amide nitrogen increases the acidity of the NH proton and alters the hydrogen-bonding capacity of the side chain. This modification, often coupled with oxidation at C-3 and C-7 (creating diones), enhances cellular uptake and interaction with intracellular targets involved in apoptosis.

Key Data: Cytotoxicity Profile (IC

in

M)[1]

Compound Derivative	HCT-116 (Colon)	MCF-7 (Breast)	K562 (Leukemia)	SGC-7901 (Gastric)
10c (N-methylsulfonyl)	4.12 ± 0.3	5.23 ± 0.4	3.89 ± 0.2	> 50
10f (N-phenylsulfonyl)	2.39 ± 0.1	3.15 ± 0.2	2.88 ± 0.1	> 50
Ursodeoxycholic Acid (Control)	> 100	> 100	> 100	> 100

Data synthesized from Ren et al. (2013).[2]

Validated Protocol: MTT Cytotoxicity Screen

Objective: Determine the IC

of novel cholanamide derivatives.

- Seeding: Plate HCT-116 cells at

cells/well in 96-well plates using RPMI-1640 medium. Incubate for 24h at 37°C/5% CO

- Treatment: Dissolve **Cholan-24-amide** derivatives in DMSO (stock 10 mM). Prepare serial dilutions in culture medium. Add 100

L/well (Final DMSO < 0.1%).

- Incubation: Incubate for 48 hours.

- Labeling: Add 20

L of MTT solution (5 mg/mL in PBS) to each well. Incubate for 4 hours.

- Solubilization: Aspirate supernatant carefully. Add 150

L DMSO to dissolve purple formazan crystals. Shake for 10 min.

- Readout: Measure absorbance at 570 nm (reference 630 nm). Calculate IC

using non-linear regression (GraphPad Prism).

Part 3: Antimicrobial Defense – Cationic Facial Amphiphiles

The rise of multidrug-resistant (MDR) bacteria has renewed interest in "membrane-active" small molecules. **Cholan-24-amides** modified with cationic groups (e.g., polyamines or benzylamines) at C-3 or C-24 mimic the mechanism of antimicrobial peptides (AMPs) but with higher stability.

Mechanism: The "Carpet" Model

These molecules do not target a specific protein. Instead, they rely on facial amphiphilicity.

- Electrostatic Attraction: The positively charged amide/amine groups attract the molecule to the negatively charged bacterial cell envelope (LPS in Gram-negatives, Teichoic acids in Gram-positives).
- Insertion: The hydrophobic steroid backbone inserts into the lipid bilayer.
- Disruption: Accumulation causes membrane depolarization and pore formation, leading to cell lysis.

Experimental Workflow: MIC Determination

To validate antimicrobial potential, a broth microdilution assay is required.

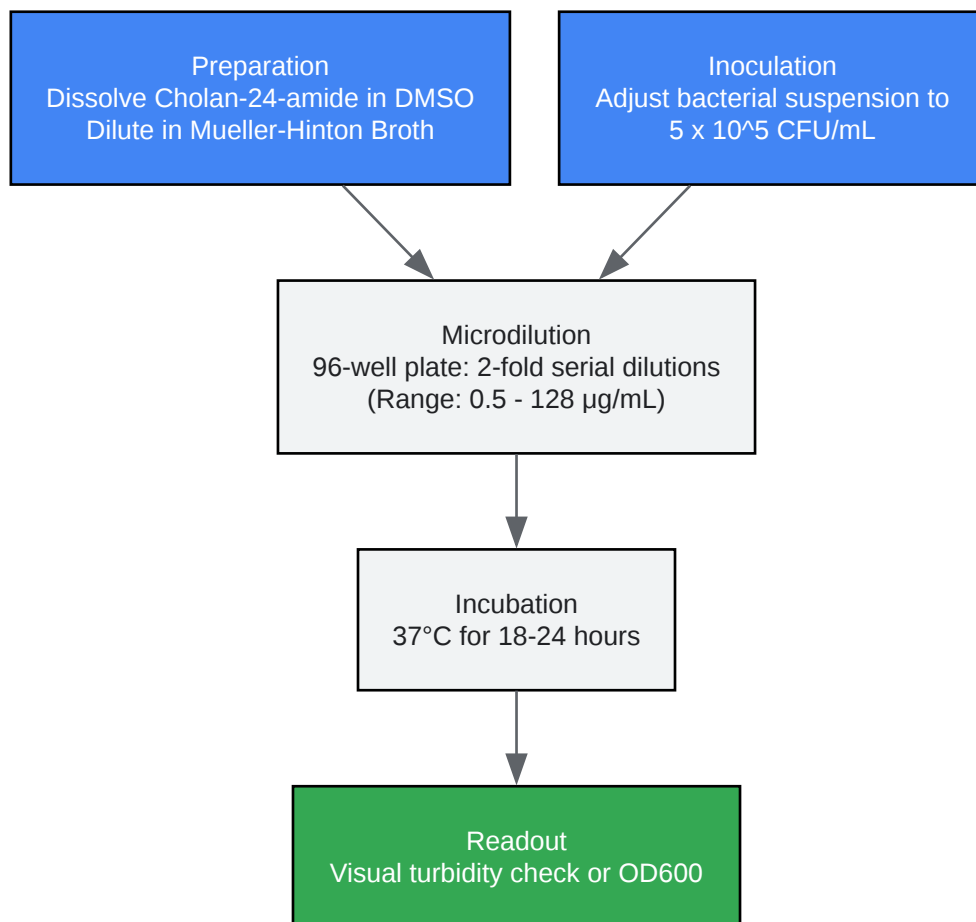

[Click to download full resolution via product page](#)

Figure 2: Standardized workflow for determining Minimum Inhibitory Concentration (MIC) of bile acid amides.

Part 4: Supramolecular Drug Delivery – Organogels

Cholan-24-amides are exceptional Low-Molecular-Weight Organogelators (LMWGs). They can immobilize organic solvents and oils at concentrations < 2 wt%, forming viscoelastic gels. This is critical for transdermal drug delivery and sustained-release depot injections.

Gelation Mechanism

The amide bond at C-24 provides a hydrogen bond donor/acceptor motif. When stacked, the steroid backbones interact via Van der Waals forces, while the amides form a 1D hydrogen-bonded network. These fibers entangle to trap the solvent.

Applications:

- Transdermal Delivery: Organogels containing permeation enhancers (e.g., lecithin) and **cholan-24-amides** can carry hydrophobic drugs (e.g., NSAIDs) across the stratum corneum.
- pH-Sensitive Liposomes: **Cholan-24-amide** derivatives embedded in liposomes can act as "molecular switches." At acidic pH (e.g., tumor microenvironment), the amide/amine protonates, causing the lipid to flip, destabilize the membrane, and release the payload.

Validated Protocol: Inverted Tube Gelation Test

Objective: Determine the Critical Gelation Concentration (CGC).

- Preparation: Weigh varying amounts of **Cholan-24-amide** derivative (e.g., 5, 10, 20 mg) into screw-cap vials.
- Solvent Addition: Add 1.0 mL of the target solvent (e.g., toluene, isopropyl myristate, or vegetable oil).
- Heating: Heat the vial in a dry block at 90°C until the solid dissolves completely (clear solution).
- Cooling: Allow the solution to cool to room temperature (25°C) undisturbed for 1 hour.
- Inversion: Invert the vial.
 - Gel: No flow is observed.
 - Sol: Liquid flows.
 - Precipitate: Solid aggregates settle.
- Calculation: The lowest concentration yielding a stable gel is the CGC.

References

- Ren, J., et al. (2013).[2] Synthesis and antitumor activity of N-sulfonyl-3,7-dioxo-5 β -**cholan-24-amides**, ursodeoxycholic acid derivatives.[2] Steroids, 78(1), 53-58.[2] [Link](#)
- Martínez, M. D., et al. (2018). Synthesis and activity evaluation of a series of cholanamides as modulators of the liver X receptors. Bioorganic & Medicinal Chemistry, 26(5), 1092-1101. [Link](#)
- Khan, S. N., et al. (2008).[3] Synthesis and antimicrobial activity of 7 α -amino-23,24-bisnor-5 α -cholan-22-ol derivatives.[1][3][4] Bioorganic & Medicinal Chemistry Letters, 18(8), 2558-2561.[3] [Link](#)
- Tang, C. C., et al. (2024). Probing Antimicrobial Activity and Mechanism of Action of a Bile Acid-Derived Antibiotic. ACS Omega, 10(1). [Link](#)
- Gu, X., et al. (2025). Rational Design of pH-Switchable 3 α -Amino Lithocholate-Modified Lipids for Efficient siRNA Delivery. ResearchGate.[5] [Link](#)
- Sgarlata, C., et al. (2016). Organogels: Properties and Applications in drug delivery. NIT Rourkela. [Link](#)

Need Custom Synthesis?

BenchChem offers custom synthesis for rare earth carbides and specific isotopic labeling.

Email: info@benchchem.com or [Request Quote Online](#).

Sources

- 1. [researchgate.net](https://www.researchgate.net) [[researchgate.net](https://www.researchgate.net)]
- 2. Synthesis and antitumor activity of N-sulfonyl-3,7-dioxo-5 β -cholan-24-amides, ursodeoxycholic acid derivatives - PubMed [pubmed.ncbi.nlm.nih.gov]
- 3. Synthesis and antimicrobial activity of 7 alpha-amino-23,24-bisnor-5 alpha-cholan-22-ol derivatives - PubMed [pubmed.ncbi.nlm.nih.gov]
- 4. [sphinxesai.com](https://www.sphinxesai.com) [[sphinxesai.com](https://www.sphinxesai.com)]

- [5. researchgate.net \[researchgate.net\]](#)
- To cite this document: BenchChem. [Potential Therapeutic Applications of Cholan-24-amide Scaffolds]. BenchChem, [2026]. [Online PDF]. Available at: [<https://www.benchchem.com/product/b14683680/docs#potential-therapeutic-applications-of-cholan-24-amide-scaffolds>]

Disclaimer & Data Validity:

The information provided in this document is for Research Use Only (RUO) and is strictly not intended for diagnostic or therapeutic procedures. While BenchChem strives to provide accurate protocols, we make no warranties, express or implied, regarding the fitness of this product for every specific experimental setup.

Technical Support: The protocols provided are for reference purposes. Unsure if this reagent suits your experiment?

Need Industrial/Bulk Grade? [Request Custom Synthesis Quote](#)

BenchChem

Our mission is to be the trusted global source of essential and advanced chemicals, empowering scientists and researchers to drive progress in science and industry.

Contact

Address: 3281 E Guasti Rd
Ontario, CA 91761, United States
Phone: (601) 213-4426
Email: info@benchchem.com

[Contact our Ph.D. Support Team for a compatibility check](#)