

2-(2-Piperidin-2-ylethoxy)pyrimidine structural analysis and confirmation

Author: BenchChem Technical Support Team. **Date:** April 2026

Compound of Interest

Compound Name: 2-(2-Piperidin-2-ylethoxy)pyrimidine
CAS No.: 1248746-24-8
Cat. No.: B1467079

[Get Quote](#)

Part 1: Executive Summary

This technical guide outlines the structural confirmation protocol for 2-(2-(piperidin-2-yl)ethoxy)pyrimidine, a critical heterocyclic intermediate often encountered in the synthesis of kinase inhibitors and GPCR ligands.

The structural integrity of this molecule hinges on three specific challenges:

- **Regioselectivity:** Distinguishing between the desired O-alkylation (ether) and the thermodynamic N-alkylation (pyrimidone) byproduct during synthesis.
- **Chirality:** The C2 position of the piperidine ring is a stereocenter; enantiomeric purity is non-negotiable for downstream biological efficacy.
- **Connectivity:** Verifying the ethylene linker attachment between the pyrimidine C2-position and the piperidine C2-position.

This document provides a self-validating analytical workflow combining High-Resolution Mass Spectrometry (HRMS), 1D/2D Nuclear Magnetic Resonance (NMR), and Chiral HPLC.

Part 2: Chemical Identity & Synthesis Context

Understanding the synthetic origin is prerequisite to effective analysis. The target compound is typically synthesized via Nucleophilic Aromatic Substitution (

).

Target Structure: 2-(2-(Piperidin-2-yl)ethoxy)pyrimidine Molecular Formula:

Exact Mass: 207.1372 Da

Synthesis & Impurity Pathway (Graphviz Visualization)

The following diagram illustrates the synthesis and the critical N-alkylation impurity pathway that must be ruled out.

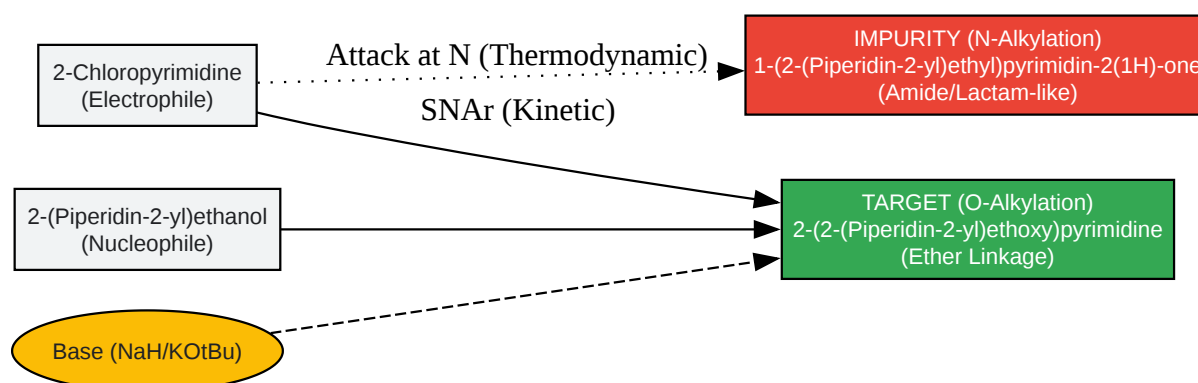

[Click to download full resolution via product page](#)

Caption: Figure 1. Competitive O-alkylation vs. N-alkylation pathways. Analytical confirmation must explicitly rule out the thermodynamic pyrimidone byproduct.

Part 3: Analytical Strategy (The Multi-Tiered Approach)

Tier 1: Mass Spectrometry (Formula Confirmation)

- Technique: ESI-TOF or Orbitrap MS (Positive Mode).
- Acceptance Criteria: Mass accuracy < 5 ppm.
- Diagnostic Ion:
.
- Fragmentation: Look for loss of the pyrimidine moiety (, neutral loss 80 Da) or the piperidine fragment (, m/z 84).

Tier 2: NMR Spectroscopy (Connectivity & Regiochemistry)

This is the primary tool for distinguishing the ether (Target) from the pyrimidone (Impurity).

- ¹H NMR (Proton):
 - Pyrimidine Protons: A standard 2-substituted pyrimidine (unsubstituted at 4,5,6) shows a distinct pattern: A doublet (~8.5 ppm, 2H, H-4/6) and a triplet (~6.9 ppm, 1H, H-5).
 - Linker Protons: The triplet is the most diagnostic signal. In the O-alkylated product, this shifts downfield (~4.4 ppm). In the N-alkylated impurity, the signal appears further upfield (~3.8–4.0 ppm).
- ¹³C NMR (Carbon):
 - C2 Carbon: The carbon attached to oxygen (Pyrimidine C2) resonates at ~165 ppm. If N-alkylation occurred (C=O bond), this signal shifts to ~155-160 ppm (carbonyl-like).

Tier 3: Chiral Purity

- Technique: Chiral HPLC or SFC.

- Column: Polysaccharide-based (e.g., Chiralpak AD-H or OD-H).
- Mobile Phase: Hexane/IPA/Diethylamine (DEA) to suppress peak tailing from the basic piperidine amine.

Part 4: Detailed Experimental Protocols

Protocol A: NMR Sample Preparation & Acquisition

Self-Validating Step: Use

with TMS as an internal standard. If the piperidine NH proton is broad or exchanges, add a drop of

to confirm the exchangeable proton, or use

to see the NH coupling.

- Dissolution: Dissolve 10 mg of the sample in 600 μ L of .
- Filtration: Filter through a cotton plug into the NMR tube to remove inorganic salts (NaCl/KCl) from the synthesis.
- Acquisition:
 - ^1H (16 scans): Set relaxation delay () to 2.0s to ensure integration accuracy of aromatic protons.
 - ^{13}C (512 scans): Critical for observing the quaternary C2 carbon.
 - COSY & HSQC: Run standard gradient sequences to map the ethyl linker connectivity.

Protocol B: Chiral HPLC Method

- Column: Daicel Chiralpak AD-H (mm, 5 μ m).

- Mobile Phase: n-Hexane : Isopropanol : Diethylamine (90 : 10 : 0.1 v/v/v).
- Flow Rate: 1.0 mL/min.
- Detection: UV at 254 nm (Pyrimidine absorption).
- Temperature: 25°C.
- Validation: Inject the racemate first to establish separation conditions ().

Part 5: Data Interpretation & Visualization

Table 1: Expected NMR Chemical Shifts ()

Position	Atom Type	¹ H Shift (, ppm)	Multiplicity	¹³ C Shift (, ppm)	Diagnostic Note
Pyrimidine					
2	C-O	-	-	165.2	Key for O-alkylation
4, 6	CH	8.52	Doublet (Hz)	158.5	Deshielded by N
5	CH	6.95	Triplet (Hz)	116.0	
Linker					
		4.45	Triplet	66.5	>4.2 ppm confirms Ether
-Pip		1.8 - 2.0	Multiplet	35.0	
Piperidine					
2'	CH	2.6 - 2.8	Multiplet	56.0	Chiral Center
6'		2.6 (eq), 3.0 (ax)	Multiplet	46.5	Adjacent to NH
3',4',5'		1.2 - 1.7	Multiplet	24-32	Ring envelope
NH	NH	1.5 - 2.0	Broad	-	exchangeable

Structural Confirmation Logic (Graphviz)

This flowchart guides the scientist through the decision process to confirm the structure or reject the batch.

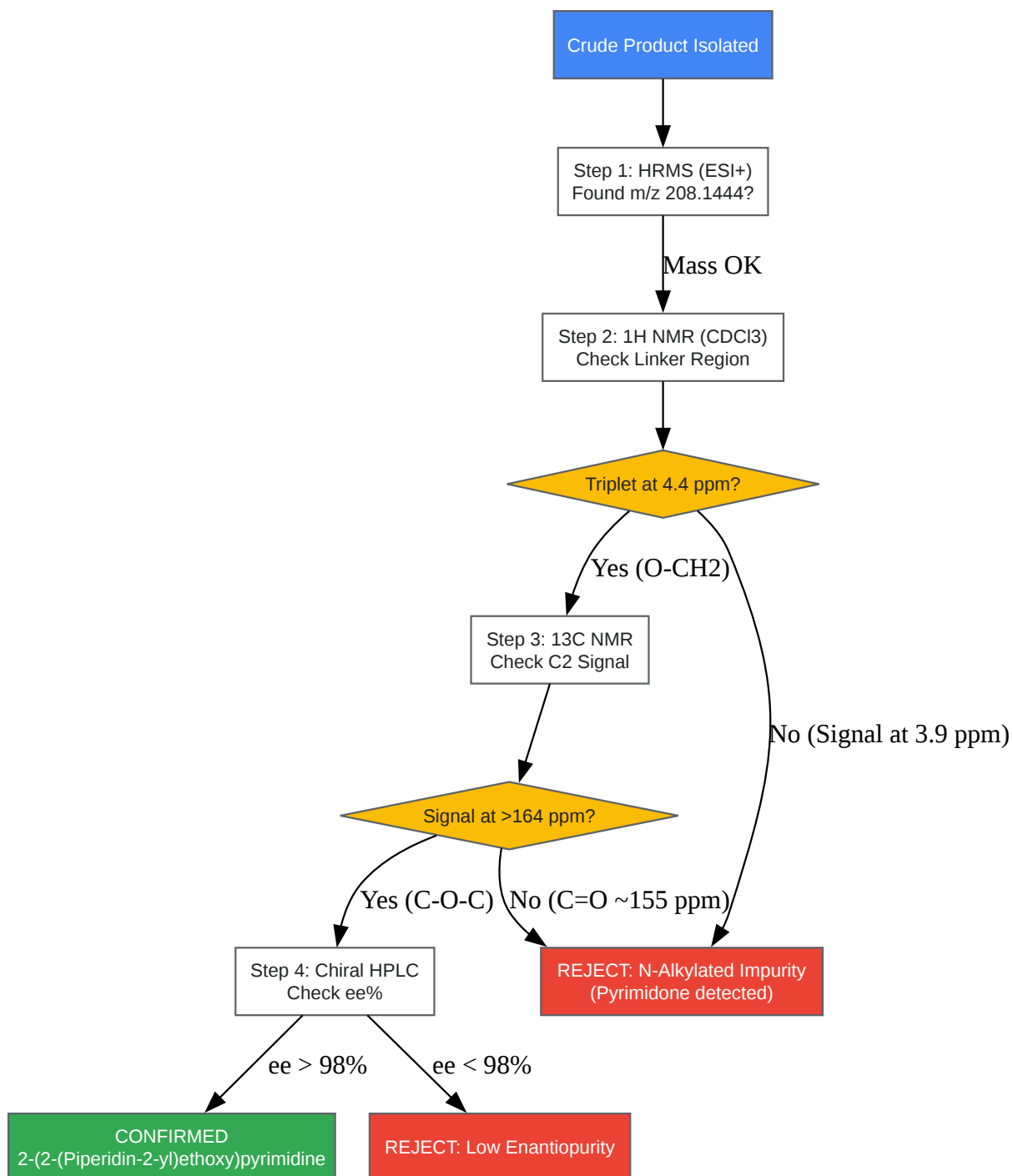

[Click to download full resolution via product page](#)

Caption: Figure 2. Analytical Decision Matrix. The critical control points are the NMR chemical shift of the linker methylene and the pyrimidine C2 carbon.

References

- General Pyrimidine Synthesis & Properties
 - Title: An overview on synthesis and biological activity of pyrimidines.
 - Source: World Journal of Advanced Research and Reviews (2022).
 - URL:[[Link](#)]
- NMR Characterization of Piperidine Derivatives
 - Title: ¹³C NMR Spectra of Saturated Heterocycles. Piperidine and N-Methylpiperidine.
 - Source: Journal of the American Chemical Society (1980) / Referenced via RSC.
 - URL:[[Link](#)]
- Analytical Methods for Piperidines: Title: A Comparative Guide to Analytical Methods for the Quantification of Ethyl-piperidin-4-ylmethyl. Source: Benchchem Technical Guides.
- Related Structural Data (2-alkoxypyrimidines)
 - Title: 2-(Piperidin-4-yloxy)pyrimidine | C₉H₁₃N₃O | CID 3836732.[1]
 - Source: PubChem.[1]
 - URL:[[Link](#)]

Need Custom Synthesis?

BenchChem offers custom synthesis for rare earth carbides and specific isotopic labeling.

Email: info@benchchem.com or [Request Quote Online](#).

Sources

- 1. 2-(Piperidin-4-yloxy)pyrimidine | C₉H₁₃N₃O | CID 3836732 - PubChem [pubchem.ncbi.nlm.nih.gov]
- To cite this document: BenchChem. [2-(2-Piperidin-2-ylethoxy)pyrimidine structural analysis and confirmation]. BenchChem, [2026]. [Online PDF]. Available at: [<https://www.benchchem.com/product/b1467079/docs#2-2-piperidin-2-ylethoxy-pyrimidine-structural-analysis-and-confirmation>]

Disclaimer & Data Validity:

The information provided in this document is for Research Use Only (RUO) and is strictly not intended for diagnostic or therapeutic procedures. While BenchChem strives to provide accurate protocols, we make no warranties, express or implied, regarding the fitness of this product for every specific experimental setup.

Technical Support: The protocols provided are for reference purposes. Unsure if this reagent suits your experiment?

Need Industrial/Bulk Grade? [Request Custom Synthesis Quote](#)

BenchChem

Our mission is to be the trusted global source of essential and advanced chemicals, empowering scientists and researchers to drive progress in science and industry.

Contact

Address: 3281 E Guasti Rd
Ontario, CA 91761, United States
Phone: (601) 213-4426
Email: info@benchchem.com

[Contact our Ph.D. Support Team for a compatibility check](#)