

2-Chloro-1-pentene (CAS: 42131-85-1): A Technical Overview

Author: BenchChem Technical Support Team. **Date:** May 2026

Compound of Interest

Compound Name: 2-Chloro-1-pentene

CAS No.: 42131-85-1

Cat. No.: B14668074

[Get Quote](#)

For Researchers, Scientists, and Drug Development Professionals

Introduction

2-Chloro-1-pentene, with the Chemical Abstracts Service (CAS) registry number 42131-85-1, is a chlorinated alkene of interest in synthetic organic chemistry. Its structure, featuring a vinyl chloride moiety attached to a propyl group, presents a versatile platform for a variety of chemical transformations. This technical guide provides a concise summary of its known properties, based on available data. Due to its specific nature, comprehensive experimental protocols and biological pathway information are not extensively documented in publicly accessible literature.

Physicochemical Properties

A summary of the key physicochemical properties of **2-Chloro-1-pentene** is presented below. These values are primarily derived from computational models and aggregated chemical databases.

Property	Value	Source
Molecular Formula	C ₅ H ₉ Cl	PubChem
Molecular Weight	104.57 g/mol	PubChem
Boiling Point	96.0 °C (Predicted)	Chemspider
Density	0.9±0.1 g/cm ³ (Predicted)	Chemspider
Refractive Index	1.427 (Predicted)	Chemspider
Flash Point	1.7±13.2 °C (Predicted)	Chemspider
Enthalpy of Vaporization	32.8±2.9 kJ/mol (Predicted)	Chemspider

Spectroscopic Data

Detailed experimental spectra for **2-Chloro-1-pentene** are not widely available. However, predicted spectral characteristics can be inferred from its structure.

- ¹H NMR: Protons on the double bond would appear as distinct signals in the vinyl region (typically 5-6 ppm). The allylic protons on the adjacent CH₂ group would likely be deshielded. The remaining protons of the propyl chain would exhibit characteristic splitting patterns in the upfield region.
- ¹³C NMR: The two olefinic carbons would be expected in the range of 110-140 ppm. The carbon bearing the chlorine atom would be significantly deshielded.
- Infrared (IR) Spectroscopy: Key vibrational modes would include C=C stretching around 1640 cm⁻¹, and C-Cl stretching in the fingerprint region (typically 600-800 cm⁻¹).

Reactivity and Synthetic Applications

The chemical reactivity of **2-Chloro-1-pentene** is dictated by the presence of the carbon-carbon double bond and the carbon-chlorine bond.

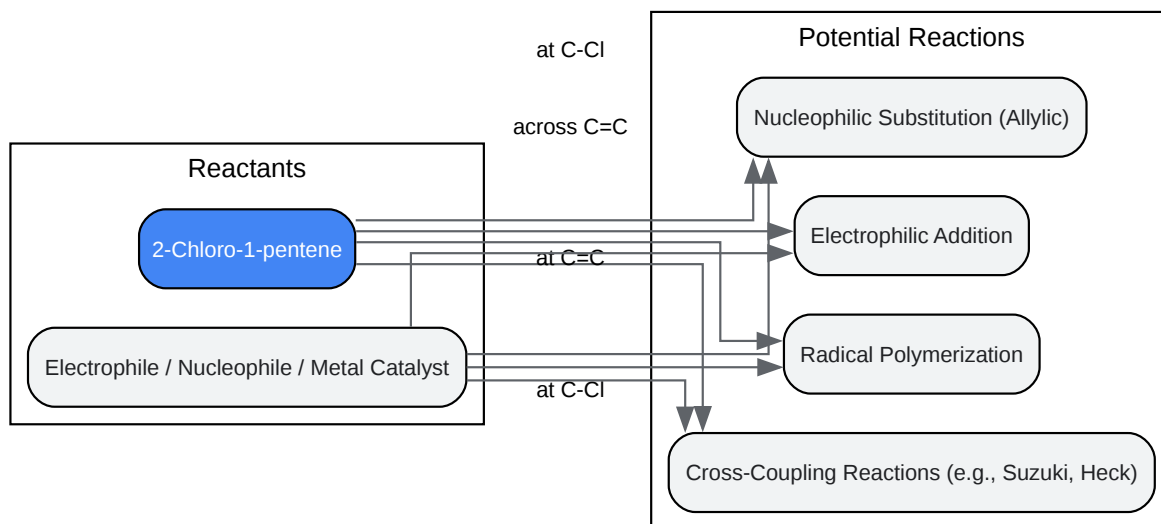

[Click to download full resolution via product page](#)

Figure 1. Potential reaction pathways for **2-Chloro-1-pentene**.

- **Electrophilic Addition:** The double bond can undergo addition reactions with various electrophiles. The regioselectivity of such additions would be governed by the electronic effects of the chlorine atom.
- **Nucleophilic Substitution:** While vinyl halides are generally unreactive towards nucleophilic substitution, under certain conditions (e.g., using a strong base to form an alkyne intermediate or through transition-metal catalysis), the chlorine atom can be displaced.
- **Cross-Coupling Reactions:** The vinyl chloride moiety makes **2-Chloro-1-pentene** a potential substrate for various transition-metal-catalyzed cross-coupling reactions, such as Suzuki, Heck, and Sonogashira couplings, allowing for the formation of new carbon-carbon bonds.
- **Polymerization:** The double bond could potentially participate in polymerization reactions, although the steric hindrance and electronic effects of the chlorine and propyl groups would influence the feasibility and outcome.

Experimental Protocols

Detailed, peer-reviewed experimental protocols for the synthesis or specific reactions of **2-Chloro-1-pentene** (CAS 42131-85-1) are not readily found in open literature. A general synthetic approach could involve the chlorination of 1-pentyne or the elimination of HCl from a dichloropentane precursor.

A hypothetical workflow for a cross-coupling reaction is outlined below.

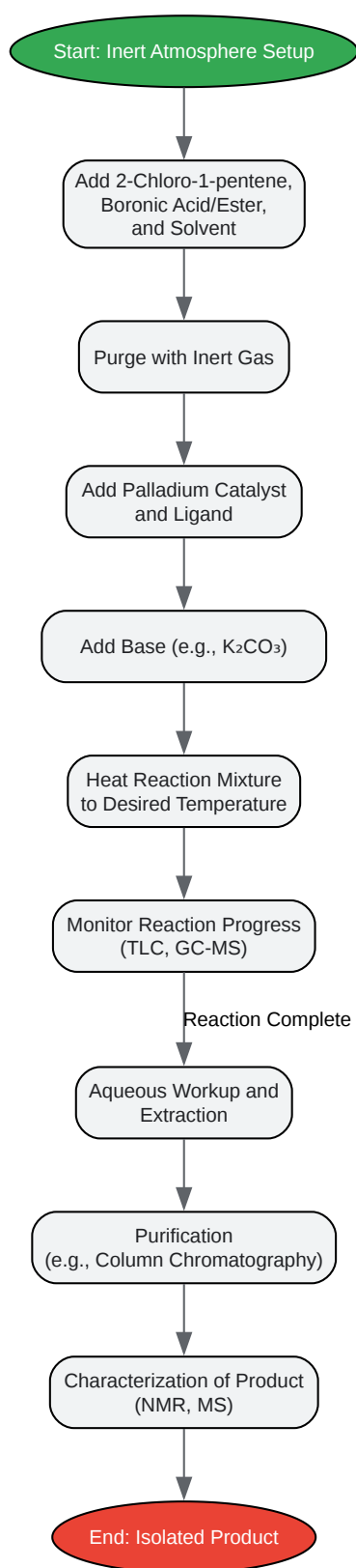

[Click to download full resolution via product page](#)

Figure 2. Generalized workflow for a Suzuki cross-coupling reaction.

Disclaimer: This document is intended for informational purposes for qualified professionals. The predicted data has not been experimentally verified and should be used with caution. All laboratory work should be conducted with appropriate safety precautions.

- To cite this document: BenchChem. [2-Chloro-1-pentene (CAS: 42131-85-1): A Technical Overview]. BenchChem, [2026]. [Online PDF]. Available at: [\[https://www.benchchem.com/product/b14668074/docs#2-chloro-1-pentene-cas-42131-85-1-a-technical-overview\]](https://www.benchchem.com/product/b14668074/docs#2-chloro-1-pentene-cas-42131-85-1-a-technical-overview)

Disclaimer & Data Validity:

The information provided in this document is for Research Use Only (RUO) and is strictly not intended for diagnostic or therapeutic procedures. While BenchChem strives to provide accurate protocols, we make no warranties, express or implied, regarding the fitness of this product for every specific experimental setup.

Technical Support: The protocols provided are for reference purposes. Unsure if this reagent suits your experiment?

Need Industrial/Bulk Grade? [Request Custom Synthesis Quote](#)

BenchChem

Our mission is to be the trusted global source of essential and advanced chemicals, empowering scientists and researchers to drive progress in science and industry.

Contact

Address: 3281 E Guasti Rd
Ontario, CA 91761, United States
Phone: (601) 213-4426
Email: info@benchchem.com

[Contact our Ph.D. Support Team for a compatibility check](#)

