

Technical Support Center: Purification of Vinyl Sulfide Products

Author: BenchChem Technical Support Team. **Date:** May 2026

Compound of Interest

Compound Name: 1-Ethenylsulfanyl-4-nitrobenzene

CAS No.: 42150-17-4

Cat. No.: B14667955

[Get Quote](#)

Welcome to the technical support guide for researchers, scientists, and drug development professionals. This resource addresses a common challenge in organic synthesis: the removal of unreacted 4-nitrothiophenol from a desired vinyl sulfide product. The presence of this vibrant yellow, odorous impurity can complicate downstream applications and compromise final product purity. This guide provides in-depth, field-proven troubleshooting advice and detailed protocols to ensure the successful isolation of your target compound.

Frequently Asked Questions (FAQs) & Troubleshooting

Q1: Why is removing residual 4-nitrothiophenol so challenging?

The difficulty in separating 4-nitrothiophenol from your vinyl sulfide product stems from their overlapping physical properties. 4-Nitrothiophenol is a yellow, crystalline solid that is soluble in many common organic solvents, much like many vinyl sulfide products.^{[1][2]} This similarity in solubility can lead to co-elution during chromatographic purification and co-precipitation during crystallization attempts.

The key to successful separation lies in exploiting the unique chemical reactivity of the thiol group (-SH) on the 4-nitrothiophenol. The nitro group (-NO₂) makes the thiol proton

significantly acidic, far more so than a typical alkyl or aryl thiol. This acidity is the leverage point for our primary purification strategies.

Table 1: Comparative Physicochemical Properties

Property	4-Nitrothiophenol	Generic Vinyl Sulfide (e.g., Phenyl Vinyl Sulfide)	Rationale for Separation Challenge
Appearance	Yellow Solid[1]	Colorless to Pale Yellow Liquid/Solid[3]	The yellow color is a useful visual indicator of the impurity.
Polarity	Moderately Polar	Varies (Generally Less Polar)	Similar polarities can cause overlapping on silica gel chromatography.
Solubility	Soluble in many organic solvents (e.g., DCM, EtOAc, Alcohols)[1]	Typically soluble in common organic solvents[3]	Shared solubility makes simple solvent washing ineffective without a chemical change.
Acidity (pKa)	~4.5 - 5.5 (estimated)	Not acidic	The acidic thiol proton is the primary handle for chemical separation.

Q2: I've just finished my reaction. What is the first and simplest purification step I should try?

The most straightforward initial purification step is a liquid-liquid extraction using a mild aqueous base. This technique, often called a "basic wash," deprotonates the acidic 4-nitrothiophenol, converting it into its water-soluble salt, 4-nitrothiophenolate. The neutral vinyl sulfide product remains in the organic layer, allowing for a clean separation.

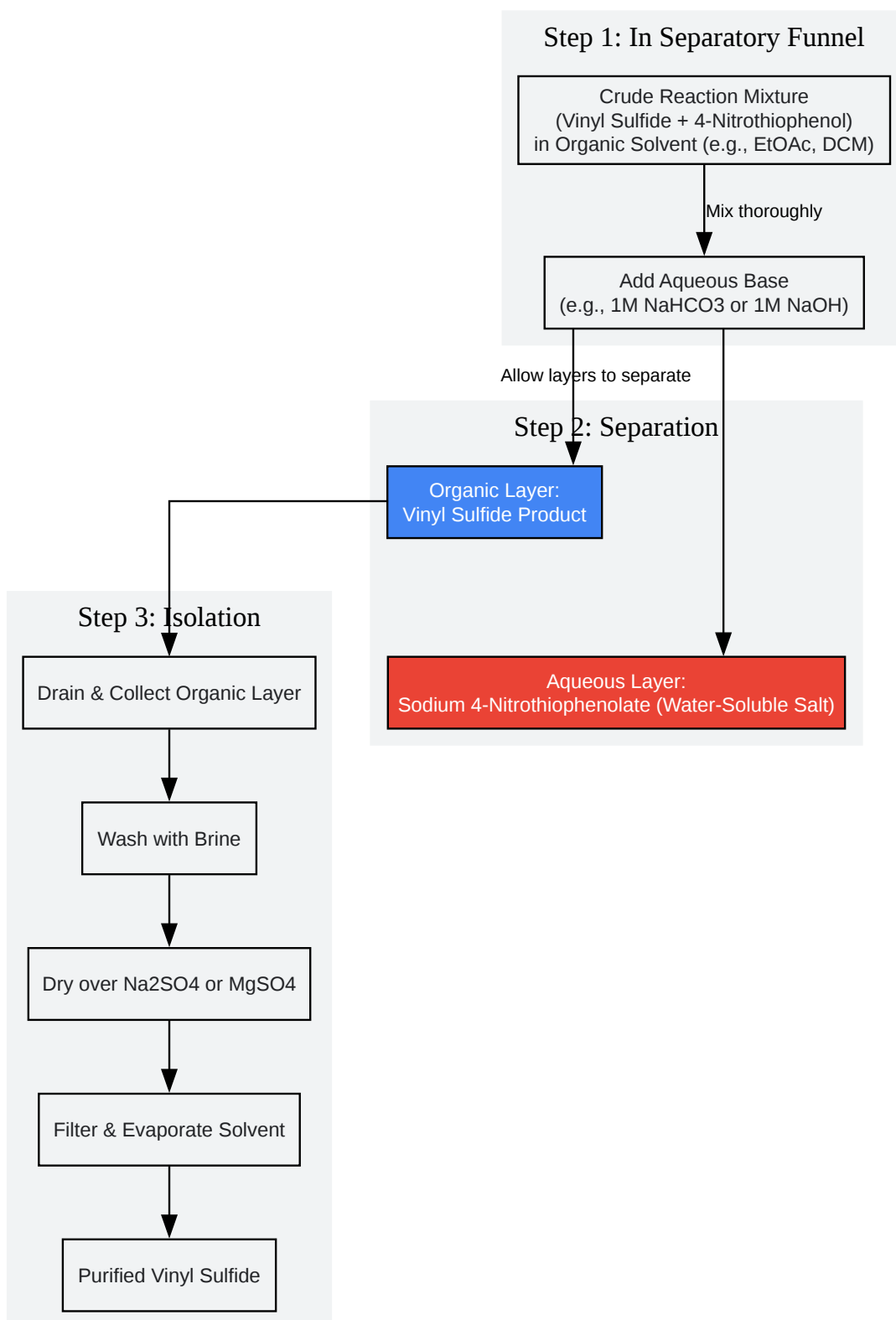

[Click to download full resolution via product page](#)

Caption: Basic extraction workflow for removing 4-nitrothiophenol.

- **Dissolution:** Ensure your crude reaction mixture is fully dissolved in a water-immiscible organic solvent like ethyl acetate (EtOAc) or dichloromethane (DCM). Transfer this solution to a separatory funnel.
- **Extraction:** Add an equal volume of a 1M aqueous solution of sodium bicarbonate (NaHCO_3) or sodium hydroxide (NaOH).
 - **Scientist's Note:** Use NaHCO_3 first, as it is a weaker base and less likely to cause side reactions with sensitive functional groups on your product. If the yellow color persists in the organic layer, a stronger base like 1M NaOH may be necessary. Be cautious with NaOH if your product contains base-labile groups (e.g., esters).
- **Mixing:** Stopper the funnel and shake vigorously for 30-60 seconds, venting frequently to release any pressure buildup (especially with bicarbonate).
- **Separation:** Allow the layers to separate. The lower aqueous layer should be bright yellow, containing the deprotonated impurity. Drain and discard this aqueous layer.
- **Repeat:** Repeat the wash 1-2 more times with fresh aqueous base until the aqueous layer is colorless.
- **Final Wash & Dry:** Wash the organic layer once with water, followed by a wash with brine to aid in removing residual water.^[4] Dry the organic layer over anhydrous sodium sulfate (Na_2SO_4) or magnesium sulfate (MgSO_4), filter, and concentrate the solvent under reduced pressure to yield your product.

Q3: The basic wash helped, but my product is still yellow. What's next?

If a basic wash is insufficient, flash column chromatography is the next logical step. This technique separates compounds based on their differential adsorption to a stationary phase (typically silica gel) and solubility in a mobile phase (the eluent).^[5] Since the vinyl sulfide is generally less polar than the 4-nitrothiophenol, it will travel through the column faster.

Caption: Step-by-step workflow for flash column chromatography.

- **Solvent System Selection (TLC):** Use Thin Layer Chromatography (TLC) to find an appropriate eluent system. The goal is to find a solvent mixture where your vinyl sulfide product has an R_f value of approximately 0.3-0.4, and the 4-nitrothiophenol spot is well-separated (ideally at the baseline or a much lower R_f).
- **Column Packing:** Pack a glass column with silica gel using your chosen eluent system (either as a slurry or dry-packed and then wetted).[6]
- **Sample Loading:** Dissolve your crude product in a minimal amount of DCM or the eluent. For best results, adsorb the crude material onto a small amount of silica gel, evaporate the solvent, and load the resulting dry powder onto the top of the column (dry loading).[7]
- **Elution:** Run the column by applying positive pressure (flash chromatography). Begin collecting fractions immediately.
- **Monitoring:** Monitor the fractions by TLC to identify which ones contain your pure product. The yellow band of 4-nitrothiophenol should move much more slowly or remain at the top of the column.
- **Isolation:** Combine the pure fractions and remove the solvent under reduced pressure.

Table 2: Suggested Starting Eluent Systems for TLC Analysis

Solvent System (v/v)	Polarity	Comments
10% Ethyl Acetate / Hexanes	Low	Good starting point for non-polar vinyl sulfides.
20% Ethyl Acetate / Hexanes	Medium	Increase polarity if the product has a low R _f in 10% EtOAc.
5% Ether / Dichloromethane	Medium	Good alternative system; DCM can improve the solubility of some compounds.

Q4: I've tried extraction and chromatography, but I still can't get rid of the last traces of 4-nitrothiophenol. What other methods can I use?

For stubborn impurities, more specialized techniques are required. Recrystallization and the use of scavenger resins are powerful alternatives.

Recrystallization purifies a solid compound by dissolving it in a hot solvent and allowing it to slowly cool, forming pure crystals while impurities remain in the solution.^[8] This method is only suitable if your vinyl sulfide product is a solid at room temperature.

- Principle: The ideal recrystallization solvent will dissolve your vinyl sulfide product when hot but not when cold.^[9] The 4-nitrothiophenol impurity, being present in a small amount, will ideally remain in the cold solvent (the "mother liquor").
- Procedure:
 - Find a suitable solvent or solvent pair (e.g., ethanol/water, hexanes/ethyl acetate) by testing small samples.^[10]
 - Dissolve the impure solid in the minimum amount of boiling solvent.
 - If the solution is colored by the impurity, you can add a small amount of activated charcoal to adsorb it, then hot-filter the solution.^[8]
 - Allow the solution to cool slowly to room temperature, then in an ice bath, to induce crystallization.
 - Collect the pure crystals by vacuum filtration, washing them with a small amount of cold solvent.

Scavenger resins are solid-supported reagents designed to react with and "scavenge" specific types of impurities from a solution.^[11] For this problem, a thiol-scavenging resin is ideal. These resins are often polystyrene or silica-based and are functionalized with groups that covalently bind to thiols.^{[12][13]}

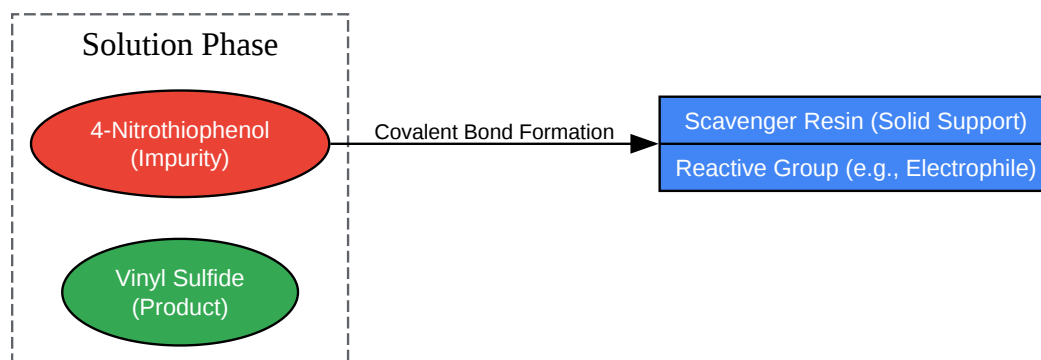

[Click to download full resolution via product page](#)

Caption: How a scavenger resin selectively removes thiol impurities.

- Types of Resins:
 - Electrophile-based scavengers: Resins functionalized with groups like maleimide or iodoacetamide will react with the nucleophilic thiol.
 - Metal-scavenging resins: Some thiol-functionalized resins are excellent at scavenging metals, but can also be used in reverse to bind other thiols.[14]
- Detailed Protocol: Scavenger Resin Purification
 - Choose a Resin: Select a commercially available thiol scavenger resin (e.g., ISOLUTE® Si-Thiol, MP-Thiol).[12][13]
 - Dissolve: Dissolve your impure product in a compatible solvent (e.g., DCM, THF, DMF). [13]
 - Add Resin: Add the scavenger resin to the solution (typically 3-5 equivalents relative to the estimated amount of impurity).
 - Stir: Stir the mixture at room temperature or with gentle heating according to the manufacturer's instructions for several hours or overnight.

- Filter: Filter the reaction mixture to remove the resin, which now has the 4-nitrothiophenol covalently bound to it.
- Isolate: Wash the resin with fresh solvent to recover any adsorbed product. Combine the filtrates and evaporate the solvent to obtain your purified vinyl sulfide.

References

- Supra Sciences. (n.d.). Thiol (SH). Retrieved from [\[Link\]](#)
- Biotage. (n.d.). Metal scavengers for organic purification. Retrieved from [\[Link\]](#)
- Biotage. (n.d.). ISOLUTE® Si-Thiol | Metal scavenger. Retrieved from [\[Link\]](#)
- ResearchGate. (n.d.). Chemical structures of vinyl sulfides. Retrieved from [\[Link\]](#)
- RSC Publishing. (2019). 1,4-Benzenedimethanethiol (1,4-BDMT) as a scavenger for greener peptide resin cleavages. RSC Advances. Retrieved from [\[Link\]](#)
- Wikipedia. (n.d.). 4-Nitrothiophenol. Retrieved from [\[Link\]](#)
- National Center for Biotechnology Information. (n.d.). Phenyl Vinyl Sulfide. PubChem Compound Database. Retrieved from [\[Link\]](#)
- Organic Chemistry Portal. (n.d.). Use of Vinyl Sulfides in Fischer Indole Reactions. Retrieved from [\[Link\]](#)
- University of California, Los Angeles. (n.d.). Recrystallization. Retrieved from [\[Link\]](#)
- American Chemical Society. (2022). Base-Promoted Synthesis of Vinyl Sulfides from Sulfonium Triflates. The Journal of Organic Chemistry. Retrieved from [\[Link\]](#)
- ResearchGate. (n.d.). General-base catalysis of the elimination of 4-nitrothiophenol.... Retrieved from [\[Link\]](#)
- University of Rochester. (n.d.). Purification: Tips for Flash Column Chromatography. Department of Chemistry. Retrieved from [\[Link\]](#)

- MDPI. (n.d.). Removal of 4-Nitrophenol from Aqueous Solution by Using Polyphenylsulfone-Based Blend Membranes. Retrieved from [\[Link\]](#)
- The Good Scents Company. (n.d.). vinyl sulfide, 627-51-0. Retrieved from [\[Link\]](#)
- National Center for Biotechnology Information. (n.d.). Advances in 4-Nitrophenol Detection and Reduction Methods and Mechanisms. PMC. Retrieved from [\[Link\]](#)
- Chemistry LibreTexts. (2023). Recrystallization. Retrieved from [\[Link\]](#)
- University of Rochester. (n.d.). Tips & Tricks: Recrystallization. Department of Chemistry. Retrieved from [\[Link\]](#)
- YouTube. (2020). Recrystallization. Retrieved from [\[Link\]](#)
- University of Rochester. (n.d.). Remove Sticky Reagents. Department of Chemistry. Retrieved from [\[Link\]](#)
- Organic Syntheses. (n.d.). phenyl vinyl sulfide. Retrieved from [\[Link\]](#)
- ResearchGate. (2024). Which is the best organic solvent for nitrophenol solubility and extraction?. Retrieved from [\[Link\]](#)
- Mettler Toledo. (n.d.). Recrystallization Guide: Process, Procedure, Solvents. Retrieved from [\[Link\]](#)
- Chemistry Stack Exchange. (2018). Fast way to isolate 4-nitrophenol from 4-aminophenol. Retrieved from [\[Link\]](#)
- Google Patents. (n.d.). CN102321001A - Synthesis method for 4-methyl-2-nitrothiophenol serving as chelating agent.
- Google Patents. (n.d.). US5632898A - Method for removing unreacted electrophiles from a reaction mixture.
- University of Rochester. (n.d.). Organic Reaction Workup Formulas for Specific Reagents. Department of Chemistry. Retrieved from [\[Link\]](#)

- Organic Chemistry Portal. (n.d.). Vinyl sulfide synthesis by C-S coupling. Retrieved from [\[Link\]](#)
- Organic Syntheses. (2025). Purification of Organic Compounds by Flash Column Chromatography. Retrieved from [\[Link\]](#)
- Organic Chemistry Portal. (n.d.). Copper-Catalyzed Synthesis of Vinyl Sulfides. Retrieved from [\[Link\]](#)
- Biocompare. (n.d.). Chromatography and Separation. Retrieved from [\[Link\]](#)
- Sorbead India. (n.d.). Silica Gel | Purification of Peptides - Column Chromatography. Retrieved from [\[Link\]](#)
- ResearchGate. (n.d.). Examples of the reactions of vinyl halides to form vinyl sulfides. Retrieved from [\[Link\]](#)
- American Chemical Society. (2024). Mechanism of Plasmon-Induced Catalysis of Thiolates and the Impact of Reaction Conditions. Journal of the American Chemical Society. Retrieved from [\[Link\]](#)

Need Custom Synthesis?

BenchChem offers custom synthesis for rare earth carbides and specific isotopic labeling.

Email: info@benchchem.com or [Request Quote Online](#).

Sources

1. 4-Nitrothiophenol - Wikipedia [en.wikipedia.org]
2. 4-Nitrothiophenol | 1849-36-1 [chemicalbook.com]
3. Phenyl Vinyl Sulfide | C₈H₈S | CID 74572 - PubChem [pubchem.ncbi.nlm.nih.gov]
4. chem.rochester.edu [chem.rochester.edu]
5. biocompare.com [biocompare.com]
6. orgsyn.org [orgsyn.org]

- [7. Purification \[chem.rochester.edu\]](#)
- [8. Recrystallization \[sites.pitt.edu\]](#)
- [9. mt.com \[mt.com\]](#)
- [10. Tips & Tricks \[chem.rochester.edu\]](#)
- [11. US5632898A - Method for removing unreacted electrophiles from a reaction mixture - Google Patents \[patents.google.com\]](#)
- [12. suprasciences.com \[suprasciences.com\]](#)
- [13. biotage.com \[biotage.com\]](#)
- [14. biotage.com \[biotage.com\]](#)
- To cite this document: BenchChem. [Technical Support Center: Purification of Vinyl Sulfide Products]. BenchChem, [2026]. [Online PDF]. Available at: [\[https://www.benchchem.com/product/b14667955/docs#technical-support-center-purification-of-vinyl-sulfide-products\]](https://www.benchchem.com/product/b14667955/docs#technical-support-center-purification-of-vinyl-sulfide-products)

Disclaimer & Data Validity:

The information provided in this document is for Research Use Only (RUO) and is strictly not intended for diagnostic or therapeutic procedures. While BenchChem strives to provide accurate protocols, we make no warranties, express or implied, regarding the fitness of this product for every specific experimental setup.

Technical Support: The protocols provided are for reference purposes. Unsure if this reagent suits your experiment?

Need Industrial/Bulk Grade? [Request Custom Synthesis Quote](#)

BenchChem

Our mission is to be the trusted global source of essential and advanced chemicals, empowering scientists and researchers to drive progress in science and industry.

Contact

Address: 3281 E Guasti Rd

Ontario, CA 91761, United States

Phone: (601) 213-4426

Email: info@benchchem.com

Contact our Ph.D. Support Team for a compatibility check