

# A Researcher's Guide to Benchmarking DFT Methods for Strained Cyclic Systems

**Author:** BenchChem Technical Support Team. **Date:** May 2026

## Compound of Interest

Compound Name: Cyclopenta-1,2-diene

CAS No.: 50682-89-8

Cat. No.: B14661044

[Get Quote](#)

For researchers, scientists, and drug development professionals navigating the complexities of computational chemistry, the accurate prediction of properties in strained cyclic systems is paramount. The inherent geometric and electronic strain in molecules such as cyclophanes, bicyclic compounds, and other constrained ring systems presents a significant challenge for theoretical methods. This guide provides an objective comparison of Density Functional Theory (DFT) methods for these challenging molecules, supported by experimental and high-level computational data.

The choice of a DFT functional and basis set can profoundly impact the accuracy of calculated properties, including geometries, reaction energies, and ring strain energies (RSE). This guide offers a comprehensive overview of the performance of various DFT functionals, details the methodologies for accurate calculations, and provides a logical workflow for benchmarking studies.

## Performance of DFT Functionals for Strained Systems

The selection of an appropriate DFT functional is a critical first step. Functionals are broadly categorized into different "rungs" of Jacob's Ladder, from the simplest Local Density Approximation (LDA) to more complex hybrid and double-hybrid functionals. For strained systems, a careful balance between computational cost and accuracy is essential.

## Key Findings from Benchmarking Studies:

- **Hybrid Functionals:** Hybrid functionals, which incorporate a percentage of exact Hartree-Fock exchange, generally offer a good balance of accuracy and computational efficiency for strained systems. Functionals like B3LYP are widely used and provide reliable geometries and reasonable activation energies.[1] For higher accuracy in reaction barriers and energies, especially in pericyclic reactions involving strained transition states, the meta-hybrid GGA functional M06-2X is highly recommended.[1]
- **Dispersion Corrections:** For many strained systems, particularly larger ones where non-covalent interactions can be significant, the inclusion of dispersion corrections is crucial. The PBE0-D3 functional, a hybrid functional with Grimme's D3 dispersion correction, has shown excellent performance in benchmark studies on bond activations in systems involving cyclopropane, with a mean absolute deviation (MAD) of only 1.1 kcal mol<sup>-1</sup> from CCSD(T)/CBS reference data.[2] Similarly, PW6B95-D3 and B3LYP-D3 also perform well.[2]
- **Double-Hybrid Functionals:** For even greater accuracy, double-hybrid functionals, which include a portion of MP2 correlation, can be employed. PWPB95-D3 has demonstrated performance on par with the best hybrid functionals for bond activation energies.[2]
- **GGA Functionals:** While generally less accurate for energies than hybrid functionals, Generalized Gradient Approximation (GGA) functionals like BP86 are noted for yielding accurate geometric structures.[1] A common and cost-effective strategy is to optimize geometries with a GGA functional like BP86 and then perform single-point energy calculations with a more accurate hybrid or double-hybrid functional.[1]

## Quantitative Performance Data

The following tables summarize the performance of selected DFT functionals for properties relevant to strained cyclic systems, with data extracted from various benchmarking studies.

Table 1: Mean Absolute Deviations (MADs) for Reaction and Activation Energies (in kcal mol<sup>-1</sup>)

Functional	Category	Test Set	MAD vs. CCSD(T)/CBS
PBE0-D3	Hybrid GGA	Bond Activations (Ni, Pd)	1.1
PW6B95-D3	Hybrid meta-GGA	Bond Activations (Ni, Pd)	1.9
PWPB95-D3	Double-Hybrid	Bond Activations (Ni, Pd)	1.9
B3LYP-D3	Hybrid GGA	Bond Activations (Ni, Pd)	1.9
M06	Hybrid meta-GGA	Bond Activations (Ni, Pd)	4.9
M06-2X	Hybrid meta-GGA	Bond Activations (Ni, Pd)	6.3

Data sourced from a benchmark study on bond activations with (Ni,Pd)-based transition-metal catalysts, which included the reaction of cyclopropane.[2]

Table 2: Recommended Functionals for Different Applications in Strained Systems

Application	Recommended Functionals	Rationale
Geometry Optimization	BP86, B3LYP	Good accuracy for structures at a reasonable computational cost.[1]
Reaction/Activation Energies	M06-2X, PBE0-D3, PW6B95-D3	High accuracy for energetic properties, especially when dispersion is included.[1][2]
Ring Strain Energy (RSE)	B3LYP, M06-2X	Proven to give reliable RSE values when using appropriate reaction schemes.[3]
High-Accuracy Benchmarks	PWPB95-D3, DLPNO-CCSD(T)	Double-hybrid DFT and coupled-cluster methods for reference-quality energies.[2][4]

## Experimental and Computational Protocols

Reproducibility and accuracy are cornerstones of computational research. This section details the common methodologies used in the benchmarking of DFT methods for strained cyclic systems.

### Calculation of Ring Strain Energy (RSE)

A primary quantitative measure of strain in cyclic molecules is the Ring Strain Energy (RSE). Since RSE is not a direct physical observable, it is calculated computationally as the energy difference in a balanced chemical reaction.

- Homodesmotic Reactions: This is a highly recommended method where the types of bonds and the number of each type of atom in each valence state are conserved on both sides of the reaction. This approach effectively isolates the strain energy.[3]
  - Example for Cyclobutane:  $c\text{-C}_4\text{H}_8 + 4 \text{CH}_3\text{CH}_3 \rightarrow 4 \text{CH}_3\text{CH}_2\text{CH}_3$

- **Isodesmic Reactions:** A less restrictive type of reaction where only the number of bonds of each formal type is conserved.
- **Group Increment Methods:** The strain energy is calculated as the difference between the computed heat of formation of the strained molecule and the sum of strain-free group increments for its constituent parts.<sup>[5]</sup>

## Geometry Optimization and Vibrational Analysis

Accurate geometries are crucial for reliable energy calculations.

- **Initial Structure:** Start with a reasonable guess for the molecular geometry, which can be obtained from molecular mechanics methods or by building the molecule in a graphical interface.
- **Geometry Optimization:** Perform a full geometry optimization using the chosen DFT functional and basis set. The optimization is considered converged when the forces on all atoms and the energy change between steps are below a defined threshold.
- **Vibrational Frequency Calculation:** After optimization, a vibrational frequency analysis should be performed at the same level of theory.<sup>[5]</sup> This is essential to confirm that the optimized structure is a true minimum on the potential energy surface (no imaginary frequencies). For transition states, one imaginary frequency corresponding to the reaction coordinate is expected.

## Choice of Basis Set

The basis set determines the flexibility of the atomic orbitals used in the calculation.

- **Pople-style basis sets:** Sets like 6-31G\* and 6-311++G(d,p) are widely used and offer a good compromise between accuracy and cost for many applications.<sup>[1]</sup> The \* indicates polarization functions on heavy atoms, while (d,p) adds them to hydrogen as well. The ++ denotes the addition of diffuse functions, which are important for anions and systems with lone pairs.
- **Correlation-consistent basis sets:** Dunning's correlation-consistent basis sets, such as cc-pVTZ (correlation-consistent polarized Valence Triple-Zeta), are recommended for

benchmark-quality calculations.[1]

- Karlsruhe basis sets: The def2-TZVP (triple-zeta valence with polarization) and def2-QZVPP (quadruple-zeta valence with polarization and diffuse functions) basis sets are also commonly used, particularly in conjunction with dispersion corrections.[2]

It's important to note that larger basis sets generally lead to more accurate results but also significantly increase computational time. Studies have shown that for many DFT calculations, triple- $\zeta$  basis sets provide the best balance of efficiency and accuracy.[4]

## Visualization of Computational Workflows

To provide a clear understanding of the logical flow of a benchmarking study, the following diagrams have been generated using Graphviz.

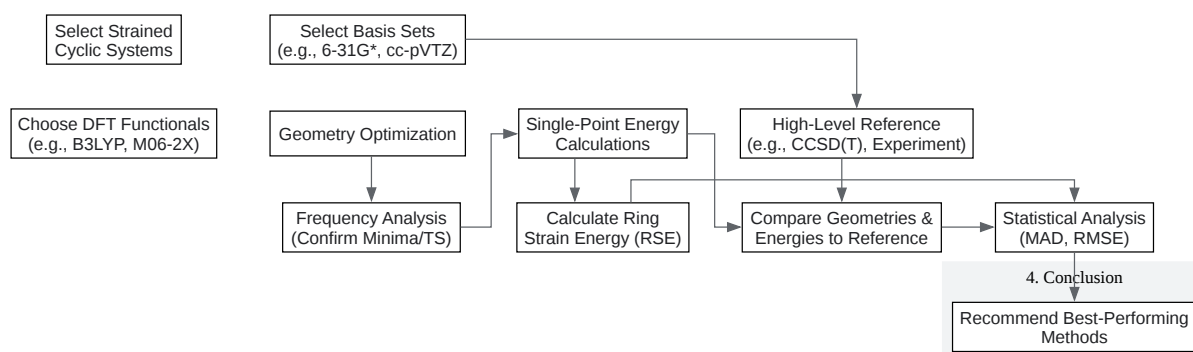

[Click to download full resolution via product page](#)

A typical workflow for benchmarking DFT methods for strained cyclic systems.

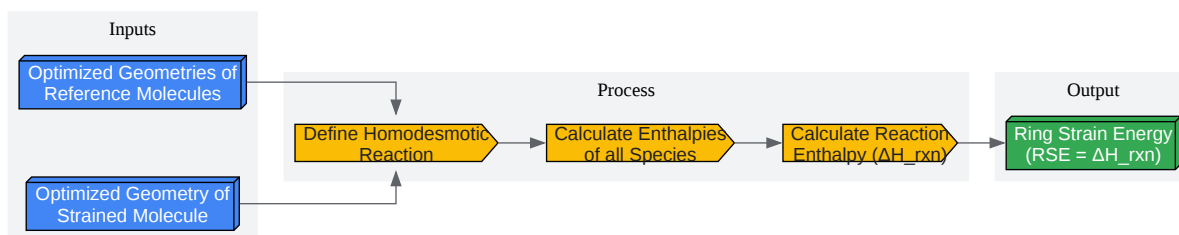

[Click to download full resolution via product page](#)

Signaling pathway for calculating Ring Strain Energy (RSE) via homodesmotic reactions.

## Conclusion

The accurate computational modeling of strained cyclic systems is a challenging yet achievable task with the careful selection of DFT methods. For general-purpose geometry and energy calculations, hybrid functionals such as B3LYP-D3 and PBE0-D3 with a triple-zeta basis set offer a robust starting point. For higher accuracy, particularly for reaction barriers, M06-2X is a strong contender. When benchmark-level accuracy is required and computational cost is less of a concern, double-hybrid functionals or coupled-cluster methods should be considered. By following the detailed protocols and workflows outlined in this guide, researchers can confidently select and apply DFT methods to gain valuable insights into the chemistry of strained cyclic molecules, accelerating research and development in fields from materials science to drug discovery.

### Need Custom Synthesis?

BenchChem offers custom synthesis for rare earth carbides and specific isotopic labeling.

Email: [info@benchchem.com](mailto:info@benchchem.com) or [Request Quote Online](#).

## References

- 1. [benchchem.com](https://www.benchchem.com) [benchchem.com]

- [2. Benchmark Study of the Performance of Density Functional Theory for Bond Activations with \(Ni,Pd\)-Based Transition-Metal Catalysts - PMC \[pmc.ncbi.nlm.nih.gov\]](#)
- [3. researchgate.net \[researchgate.net\]](#)
- [4. Benchmarking Density Functional Theory Methods for Metalloenzyme Reactions: The Introduction of the MME55 Set - PMC \[pmc.ncbi.nlm.nih.gov\]](#)
- [5. benchchem.com \[benchchem.com\]](#)
- To cite this document: BenchChem. [A Researcher's Guide to Benchmarking DFT Methods for Strained Cyclic Systems]. BenchChem, [2026]. [Online PDF]. Available at: [\[https://www.benchchem.com/product/b14661044/docs#a-researcher-s-guide-to-benchmarking-dft-methods-for-strained-cyclic-systems\]](https://www.benchchem.com/product/b14661044/docs#a-researcher-s-guide-to-benchmarking-dft-methods-for-strained-cyclic-systems)

---

### Disclaimer & Data Validity:

The information provided in this document is for Research Use Only (RUO) and is strictly not intended for diagnostic or therapeutic procedures. While BenchChem strives to provide accurate protocols, we make no warranties, express or implied, regarding the fitness of this product for every specific experimental setup.

**Technical Support:** The protocols provided are for reference purposes. Unsure if this reagent suits your experiment?

**Need Industrial/Bulk Grade?** [Request Custom Synthesis Quote](#)

## BenchChem

Our mission is to be the trusted global source of essential and advanced chemicals, empowering scientists and researchers to drive progress in science and industry.

### Contact

Address: 3281 E Guasti Rd  
Ontario, CA 91761, United States  
Phone: (601) 213-4426  
Email: [info@benchchem.com](mailto:info@benchchem.com)

Contact our Ph.D. Support Team for a compatibility check