

Application Notes and Protocols for Acidic Gold Plating using Potassium Dicyanoaurate(I)

Author: BenchChem Technical Support Team. **Date:** April 2026

Compound of Interest

Compound Name: Gold;potassium

CAS No.: 51434-62-9

Cat. No.: B14652333

[Get Quote](#)

Introduction

Potassium dicyanoaurate(I), $K[Au(CN)_2]$, is a key compound used extensively in the electrodeposition of gold. While traditionally used in alkaline and neutral cyanide baths, its application in acidic gold plating baths is crucial for producing hard, bright, and wear-resistant gold deposits, particularly for the electronics and decorative industries.[1] Acidic gold plating solutions typically operate at a pH range of 3.5 to 5.0, a range where the potassium gold cyanide complex remains stable.[1] These baths allow for the co-deposition of transition metals like cobalt, nickel, or iron, which significantly enhances the hardness and durability of the gold layer.[1] The resulting "hard gold" deposits are essential for components requiring excellent sliding wear resistance, such as electrical connectors.[1] This document provides detailed application notes and protocols for researchers and scientists working with $K[Au(CN)_2]$ in acidic gold plating baths.

Chemical Principles

The fundamental principle of gold electroplating from a $K[Au(CN)_2]$ bath is the electrochemical reduction of the stable dicyanoaurate(I) complex, $[Au(CN)_2]^-$, at the cathode (the substrate

being plated). The overall cathodic reaction is:

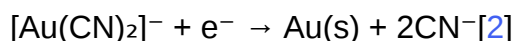

The stability of the aurocyanide complex is a critical factor in achieving a controlled and high-quality deposition.[2] In acidic solutions, the pH must be carefully controlled to remain above approximately 3.1 to prevent the decomposition of the gold cyanide complex and the precipitation of insoluble gold(I) cyanide (AuCN).[1] Additives such as citrates and phosphates are often used as buffers and conducting salts to maintain the solution's pH and conductivity.[1]

Data Presentation: Bath Composition and Operating Parameters

The composition of the acidic gold plating bath and its operating parameters are critical for determining the properties of the deposited gold layer. The following tables summarize typical compositions and conditions.

Table 1: Typical Acidic Gold Plating Bath Composition

| Component | Concentration Range | Purpose | Reference |
|---|--|--|-----------|
| Potassium Dicyanoaurate(I) (K[Au(CN) ₂]) | 0.7 - 94.0 g/L | Source of gold ions | [3][4] |
| Conducting/Buffering Salts (e.g., Citrates, Phosphates) | 30 - 150 g/L | Provides conductivity and pH buffering | [1] |
| Weak Organic Acid (e.g., Citric Acid) | 3 - 150 g/L | pH adjustment and complexing agent | [5][6] |
| Hardeners (e.g., Cobalt or Nickel salts) | As needed (e.g., 1.5 g/L Ni carbonate) | Co-deposits with gold to increase hardness | [1][7] |

Table 2: Typical Operating Parameters for Acidic Gold Plating

| Parameter | Typical Range | Effects on Deposit | Reference |
|-----------------|---|--|-----------|
| pH | 3.5 - 5.0 | Critical for bath stability and deposit quality. Lower pH can lead to HCN formation. | [1] |
| Temperature | 25 - 60 °C | Affects conductivity, deposition rate, and internal stress. | [2] |
| Current Density | 0.1 - 10 mA/cm ² (or 10 - 80 A/ft ²) | Higher densities increase plating rate but can lead to rougher deposits. | [2][3] |

Experimental Protocols

Protocol 1: Preparation of an Acidic Gold Plating Bath

This protocol describes the preparation of a 1-liter acidic gold plating bath.

Materials:

- Potassium Dicyanoaurate(I) (K[Au(CN)₂])
- Dipotassium Phosphate (K₂HPO₄) or Sodium Acid Diorthophosphate
- Citric Acid
- Deionized Water
- Potassium Hydroxide (KOH) or Phosphoric Acid for pH adjustment
- Beaker (1 L)
- Magnetic stirrer and stir bar

- pH meter

Procedure:

- In a 1 L beaker, dissolve the buffering salts (e.g., 80 g of sodium acid diorthophosphate) in approximately 750 mL of deionized water while stirring.[3]
- Slowly add the required amount of $K[Au(CN)_2]$ (e.g., 12 g) to the solution.[3] Caution: This step should be performed in a well-ventilated fume hood as some hydrogen cyanide (HCN) gas may be released.[3]
- Add the weak organic acid (e.g., citric acid) to the solution.
- Adjust the pH of the solution to the desired range (e.g., 3.5-5.0) using a dilute solution of phosphoric acid or potassium hydroxide.
- Add deionized water to bring the final volume to 1 liter.
- If required for hard gold plating, add the appropriate amount of a hardening agent, such as a nickel or cobalt salt.[6]
- The bath can be aged by heating it to around 180°F (82°C) for one hour and then allowing it to cool.[3]

Protocol 2: Substrate Preparation and Electroplating

Proper substrate preparation is crucial for achieving good adhesion and a uniform gold coating.

Materials:

- Substrate to be plated (e.g., copper, nickel)
- Cleaning solutions (e.g., acetone, isopropanol, deionized water)
- Acid activation solution (e.g., dilute sulfuric acid)
- Plating cell/beaker

- Anode (e.g., platinized titanium or stainless steel)[5][6]
- DC power supply (potentiostat/galvanostat)
- Hot plate with magnetic stirrer

Procedure:

- Substrate Cleaning:
 - Degrease the substrate by sonicating in acetone, followed by isopropanol, and finally rinse thoroughly with deionized water.
- Surface Activation:
 - Immerse the cleaned substrate in a dilute acid solution (e.g., 10% H₂SO₄) for 30-60 seconds to remove any surface oxides.
 - Rinse the activated substrate thoroughly with deionized water.
- Electroplating Setup:
 - Place the prepared acidic gold plating solution into the plating cell.
 - Submerge the anode and the prepared substrate (cathode) into the solution.
 - Connect the anode and cathode to the DC power supply.
- Deposition:
 - Heat the solution to the desired temperature (e.g., 50°C) with gentle stirring.[2]
 - Apply the desired current density (e.g., 1-5 mA/cm²) or potential.[2]
 - Continue the deposition for the calculated time to achieve the desired thickness.
- Post-Plating Treatment:
 - Once the deposition is complete, turn off the power supply.

- Remove the plated substrate and rinse it thoroughly with deionized water.
- Dry the substrate using a stream of nitrogen or in a clean oven at low temperature.

Visualizations

The following diagrams illustrate the key processes in acidic gold plating.

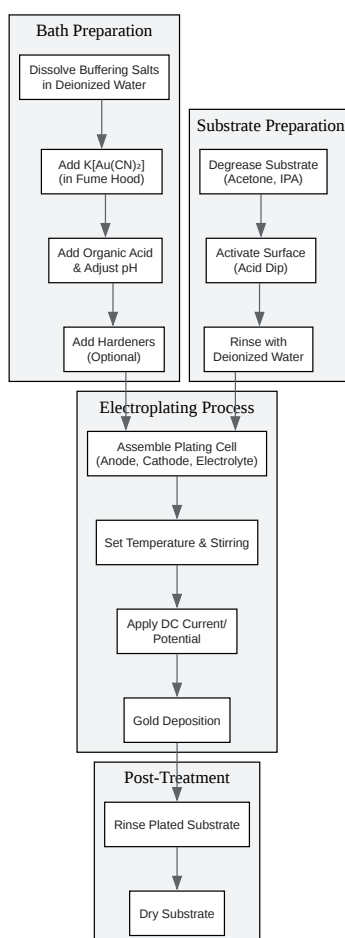

[Click to download full resolution via product page](#)

Caption: Workflow for the acidic gold plating process.

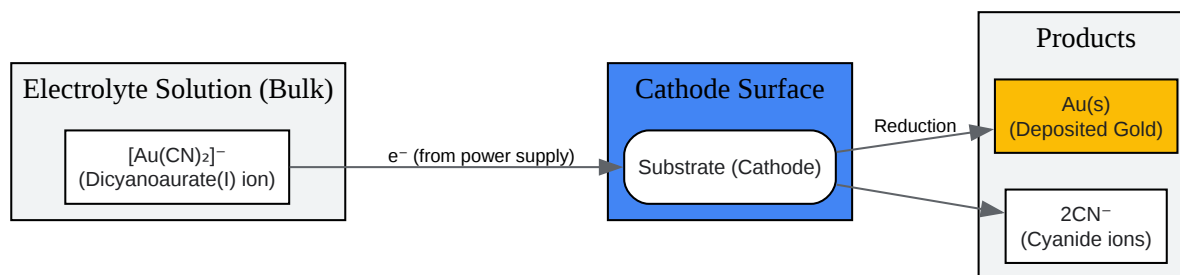

[Click to download full resolution via product page](#)

Caption: Gold deposition reaction at the cathode.

Need Custom Synthesis?

BenchChem offers custom synthesis for rare earth carbides and specific isotopic labeling.

Email: info@benchchem.com or [Request Quote Online](#).

References

- [1. nmfrc.org](http://nmfrc.org) [nmfrc.org]
- [2. benchchem.com](http://benchchem.com) [benchchem.com]
- [3. US3303112A - Acidic gold cyanide electroplating bath and process - Google Patents](#) [patents.google.com]
- [4. patentimages.storage.googleapis.com](http://patentimages.storage.googleapis.com) [patentimages.storage.googleapis.com]
- [5. Galvanische Abscheidung bestimmter Metalle von MicroChemicals GmbH](#) [microchemicals.com]
- [6. microchemicals.com](http://microchemicals.com) [microchemicals.com]
- [7. US3598706A - Acid gold plating baths - Google Patents](#) [patents.google.com]
- To cite this document: BenchChem. [Application Notes and Protocols for Acidic Gold Plating using Potassium Dicyanoaurate(I)]. BenchChem, [2026]. [Online PDF]. Available at: [<https://www.benchchem.com/product/b14652333/docs#application-notes-and-protocols-for-acidic-gold-plating-using-potassium-dicyanoaurate-i>]

Disclaimer & Data Validity:

The information provided in this document is for Research Use Only (RUO) and is strictly not intended for diagnostic or therapeutic procedures. While BenchChem strives to provide accurate protocols, we make no warranties, express or implied, regarding the fitness of this product for every specific experimental setup.

Technical Support: The protocols provided are for reference purposes. Unsure if this reagent suits your experiment?

Need Industrial/Bulk Grade? [Request Custom Synthesis Quote](#)

BenchChem

Our mission is to be the trusted global source of essential and advanced chemicals, empowering scientists and researchers to drive progress in science and industry.

Contact

Address: 3281 E Guasti Rd
Ontario, CA 91761, United States
Phone: (601) 213-4426
Email: info@benchchem.com

[Contact our Ph.D. Support Team for a compatibility check](#)