

Comparative Reactivity Profiling: 3-Bromo vs. 4-Bromo Benzoate Scaffolds

Author: BenchChem Technical Support Team. **Date:** May 2026

Compound of Interest

Compound Name: Ethyl 3-bromo-4-(diallylamino)benzoate

CAS No.: 1211511-06-6

Cat. No.: B1465528

[Get Quote](#)

Executive Summary

In the design of pharmaceutical intermediates, the choice between 3-bromobenzoate (meta) and 4-bromobenzoate (para) is rarely arbitrary. While they share a molecular formula, their reactivity profiles are orthogonal in key synthetic pathways.

- Select 4-Bromobenzoate for Nucleophilic Aromatic Substitution (S_NAr). The para-ester group provides the essential resonance stabilization required for halide displacement.
- Select 3-Bromobenzoate for Palladium-Catalyzed Cross-Coupling where oxidative addition rates are critical, or when higher solubility is required in process solvents.
- Process Warning: 3-Bromobenzoates are significantly less hydrolytically stable than their 4-isomers due to stronger inductive activation of the carbonyl.

Electronic Fundamentals: The "Why" Behind the Reactivity

The divergence in reactivity stems from how the bromine and carboxylate groups communicate across the benzene ring.

Parameter	3-Bromobenzoate (Meta)	4-Bromobenzoate (Para)	Mechanistic Implication
Hammett Constant ()			3-Br is more electron-withdrawing overall.
Dominant Effect	Induction (-I)	Resonance (+R) vs Induction (-I)	3-position relies on through-bond pull; 4-position has competing donation.
Acid Dissociation ()	~3.81	~4.00	3-Br is the stronger acid (stabilizes anion via induction).
Crystal Packing (MP)	~155°C	~252°C	4-Br packs efficiently (symmetry), reducing solubility.

Visualizing the Electronic Vectors

The following diagram illustrates why the 4-position allows for resonance conjugation, while the 3-position is electronically "disconnected" from the carbonyl's

-system.

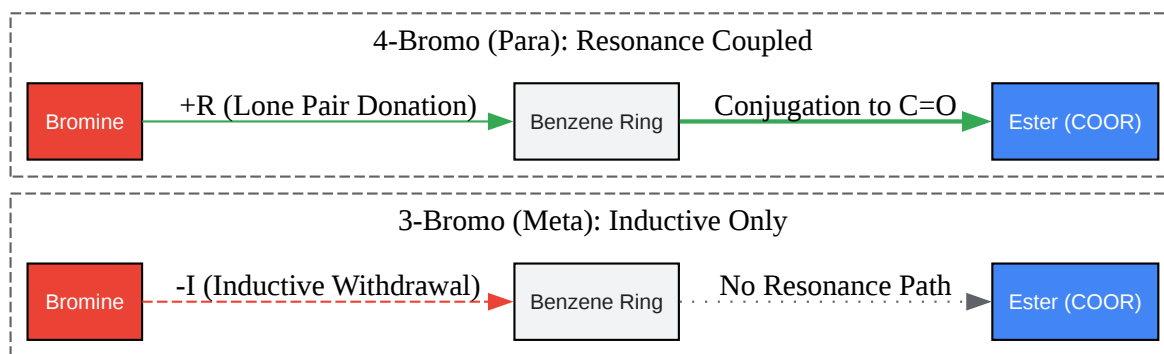

[Click to download full resolution via product page](#)

Caption: In the 4-isomer, electron density can flow directly between the bromine and the ester, affecting transition states. In the 3-isomer, this path is blocked.

Nucleophilic Aromatic Substitution (S_NAr) Performance

This is the most binary difference between the two scaffolds.

- 4-Bromobenzoate: Highly Reactive. The ester group at the para position acts as a strong electron-withdrawing group (EWG) that can accept the negative charge generated in the Meisenheimer complex intermediate. The charge delocalizes onto the carbonyl oxygen.
- 3-Bromobenzoate: Inert. The ester at the meta position cannot stabilize the Meisenheimer complex via resonance. The negative charge is confined to the ring carbons, making the energy barrier for nucleophilic attack prohibitively high under standard conditions.

Comparative Data: Amination with Morpholine

Conditions: DMSO, 100°C, 24h,

Substrate	Conversion (%)	Yield (%)	Notes
Methyl 4-bromobenzoate	>98%	92%	Clean displacement of Br.
Methyl 3-bromobenzoate	<5%	0%	Recovery of starting material.

Metal-Catalyzed Cross-Coupling (Suzuki-Miyaura)

In Palladium-catalyzed reactions, the trend is subtler and governed by the rate of Oxidative Addition (OA).

- 3-Bromobenzoate (The "Fast" Coupler):
 - Due to the higher Hammett constant (σ_p), the carbon-bromine bond is more electron-deficient.
 - Result: Faster oxidative addition of C-Br bond.
 - . This substrate is less sensitive to ligand sterics and works well with standard catalysts like $\text{Pd(PPh}_3\text{)}_4$.
- 4-Bromobenzoate (The "Resonance" Challenge):
 - The resonance donation (+R) from the bromine into the ring slightly increases electron density at the C-Br bond compared to the meta isomer.
 - Result: Slightly slower oxidative addition.^[1] However, because the ester is an EWG, it is still highly reactive compared to electron-rich aryl halides (e.g., bromoanisole).

Process Tip: For 4-bromobenzoate couplings, use electron-rich, bulky ligands (e.g., SPhos, XPhos) to accelerate the oxidative addition step if the reaction is sluggish.

Hydrolytic Stability & Process Safety

A critical but often overlooked factor in scale-up is the stability of the ester group itself.

- Reaction: Alkaline Hydrolysis (Saponification).
- Trend: 3-Bromobenzoate hydrolyzes FASTER than 4-Bromobenzoate.
- Mechanism: The alkaline hydrolysis rate depends on the electrophilicity of the carbonyl carbon. The stronger inductive withdrawal (-I) of the meta-bromine (closer proximity, higher) makes the carbonyl more susceptible to attack.

Experimental Implication: When performing Suzuki couplings under basic aqueous conditions (e.g.,

), the 3-bromo ester is at higher risk of premature hydrolysis to the acid, which can poison the catalyst or complicate purification.

Experimental Protocols

Protocol A:

Displacement (Specific to 4-Isomer)

Validates the resonance activation of the para-ester.

- Setup: Charge a reaction vial with Methyl 4-bromobenzoate (1.0 equiv, 1.0 mmol), Morpholine (1.2 equiv), and (2.0 equiv).
- Solvent: Add anhydrous DMSO (3.0 mL).
- Reaction: Heat to 100°C for 12 hours.
- Workup: Dilute with water, extract with EtOAc. The organic layer will contain the 4-morpholinobenzoate product.

- Validation: 3-bromobenzoate subjected to these exact conditions will show no product formation by TLC/LCMS.

Protocol B: Controlled Suzuki Coupling (General)

Optimized to prevent hydrolysis of the sensitive 3-isomer.

- Catalyst System: Use

(3 mol%) – robust against hydrolysis side-reactions.
- Base: Use mild

(2.0 equiv) instead of strong hydroxides.
- Solvent:Dioxane/Water (9:1). The low water content minimizes ester hydrolysis.
- Temperature:80°C.
- Note: If using 4-bromobenzoate, you may increase temperature to 100°C safely due to its higher hydrolytic stability.

Decision Tree for Scaffold Selection

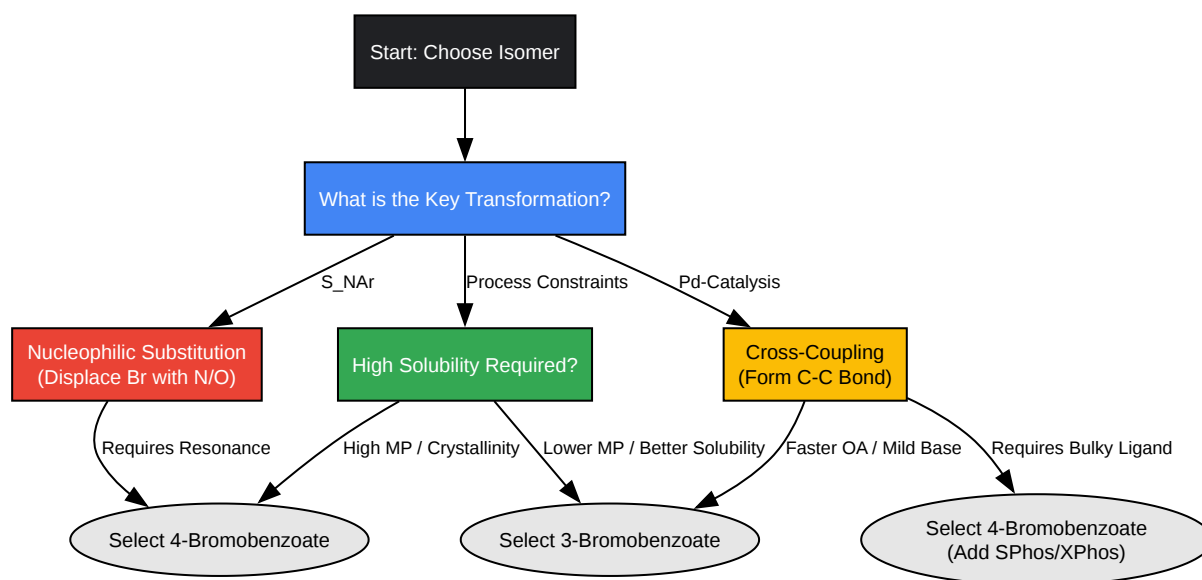

[Click to download full resolution via product page](#)

Caption: Strategic selection guide based on reaction mechanism and physical property requirements.

References

- Hansch, C., et al. "A Survey of Hammett Substituent Constants and Resonance and Field Parameters." *Chemical Reviews*, 91.2 (1991): 165-195. [Link](#)
- Bunnett, J. F. "Mechanism and reactivity in aromatic nucleophilic substitution reactions." *Quarterly Reviews, Chemical Society*, 12.1 (1958): 1-16. [Link](#)
- Littke, A. F., & Fu, G. C. "Palladium-catalyzed coupling reactions of aryl chlorides." *Angewandte Chemie International Edition*, 41.22 (2002): 4176-4211. [Link](#)
- Sigma-Aldrich. "4-Bromobenzoic acid Product Specification." [Link](#)
- PubChem. "3-Bromobenzoic acid: Experimental Properties." [Link](#)

Need Custom Synthesis?

BenchChem offers custom synthesis for rare earth carbides and specific isotopic labeling.

Email: info@benchchem.com or [Request Quote Online](#).

Sources

- 1. mirica.web.illinois.edu [mirica.web.illinois.edu]
- To cite this document: BenchChem. [Comparative Reactivity Profiling: 3-Bromo vs. 4-Bromo Benzoate Scaffolds]. BenchChem, [2026]. [Online PDF]. Available at: [<https://www.benchchem.com/product/b1465528/docs#comparative-reactivity-profiling-3-bromo-vs-4-bromo-benzoate-scaffolds>]

Disclaimer & Data Validity:

The information provided in this document is for Research Use Only (RUO) and is strictly not intended for diagnostic or therapeutic procedures. While BenchChem strives to provide accurate protocols, we make no warranties, express or implied, regarding the fitness of this product for every specific experimental setup.

Technical Support: The protocols provided are for reference purposes. Unsure if this reagent suits your experiment?

Need Industrial/Bulk Grade? [Request Custom Synthesis Quote](#)

BenchChem

Our mission is to be the trusted global source of essential and advanced chemicals, empowering scientists and researchers to drive progress in science and industry.

Contact

Address: 3281 E Guasti Rd

Ontario, CA 91761, United States

Phone: (601) 213-4426

Email: info@benchchem.com

Contact our Ph.D. Support Team for a compatibility check