

Comparative Guide: Boc vs. Cbz Protection for 7-Aminoindoline[1]

Author: BenchChem Technical Support Team. **Date:** May 2026

Compound of Interest

Compound Name: (2,3-Dihydro-1H-indol-7-yl)-
carbamic acid tert-butyl ester

CAS No.: 885270-12-2

Cat. No.: B1465098

[Get Quote](#)

Executive Summary & Strategic Selection

For researchers working with 7-aminoindoline, the choice between Boc and Cbz protection is rarely about yield alone—both are high-efficiency reactions.[1] The decision rests on regioselectivity (discriminating between the N7 primary aniline and the N1 secondary indoline amine) and downstream orthogonality.

- Select Boc Protection when: You require a protecting group that withstands catalytic hydrogenation (e.g., reducing nitro groups elsewhere) or basic conditions (e.g., alkylation of N1). The bulky tert-butyl group also offers superior kinetic selectivity for the exocyclic N7 amine over the sterically hindered N1 position.[1]
- Select Cbz Protection when: You require acid stability (e.g., using Lewis acids for subsequent transformations) or when the final deprotection must be performed under neutral conditions (hydrogenolysis) to preserve acid-sensitive motifs.

Chemical Logic: The Regioselectivity Challenge

7-Aminoindoline presents two nucleophilic nitrogen centers:

- N7 (Exocyclic): A primary aryl amine (aniline-like).[1] Sterically accessible.
- N1 (Endocyclic): A secondary aryl-alkyl amine.[1] Sterically hindered by the adjacent C2 and benzene ring fusion.[1]

Key Insight: While secondary amines are typically more basic, the N7 primary amine is kinetically more nucleophilic toward bulky electrophiles like

is less bulky and more reactive, increasing the risk of bis-protection (N1, N7-diprotection) if stoichiometry and temperature are not strictly controlled.

Comparative Performance Matrix

Feature	Boc Protection (-Boc)	Cbz Protection (Z)
Reagent	Di-tert-butyl dicarbonate ()	Benzyl chloroformate ()
Regioselectivity (N7 vs N1)	High (Steric control favors N7)	Moderate (Requires low temp/stoichiometry control)
Typical Yield (N7-mono)	90–95%	80–88%
By-products	-BuOH, (Gas)	Benzyl alcohol, HCl
Stability Profile	Stable to Bases, Nucleophiles, Hydrogenolysis.[1]	Stable to Acids (TFA/HCl), Bases (mild).
Deprotection	Acidic (TFA/DCM or HCl/Dioxane)	Hydrogenolysis (, Pd/C) or HBr/AcOH
Cost Efficiency	Moderate	High (Reagent is cheap, but purification may be harder)

Experimental Protocols

Protocol A: Regioselective N7-Boc Protection

This protocol exploits the steric bulk of

to selectively protect the N7 position without touching N1.

Reagents: 7-Aminoindoline (1.0 equiv),

(1.1 equiv),

(1.2 equiv), THF or Dioxane.

- Dissolution: Dissolve 7-aminoindoline in anhydrous THF (concentration) under an inert atmosphere ().
- Base Addition: Add triethylamine () dropwise.^[1] Note: Inorganic bases like (aq) can also be used in a biphasic system to further suppress N1 reactivity.
- Electrophile Addition: Add a solution of in THF dropwise over 20 minutes at 0°C.
- Reaction: Allow to warm to room temperature (RT) and stir for 4–6 hours. Monitor by TLC (Active ester formation at N1 is slow at RT).
- Work-up: Dilute with EtOAc, wash with citric acid (to remove unreacted amine), water, and brine. Dry over .^{[1][2]}
- Purification: Flash column chromatography (Hexane/EtOAc). N7-Boc product elutes significantly later than bis-protected impurities.^[1]

Protocol B: Controlled N7-Cbz Protection

Since

is highly reactive, low temperature and Schotten-Baumann conditions are used to prevent N1 acylation.[1]

Reagents: 7-Aminoindoline (1.0 equiv), Benzyl chloroformate (

, 1.05 equiv),

(2.5 equiv), EtOAc/Water (1:1).

- Biphasic Setup: Suspend 7-aminoindoline in a 1:1 mixture of EtOAc and saturated aqueous . Vigorously stir at 0°C.
- Controlled Addition: Add (neat or in minimal toluene) very slowly (dropwise over 30–45 mins) to the cold mixture.
 - Critical Control Point: Rapid addition causes local high concentrations, leading to N1 protection.
- Quench: Quench immediately upon consumption of starting material (approx. 1–2 hours) by adding diethylamine (0.1 equiv) to scavenge excess , or simply dilute with water.
- Work-up: Separate organic layer, wash with HCl (removes unreacted starting material), then brine.
- Purification: Recrystallization from EtOH/Hexane is often sufficient; otherwise, silica chromatography.[1]

Visualization of Pathways & Orthogonality[1]

The following diagrams illustrate the reaction pathways and the orthogonality logic for selecting the correct group.

Diagram 1: Regioselective Protection Pathways

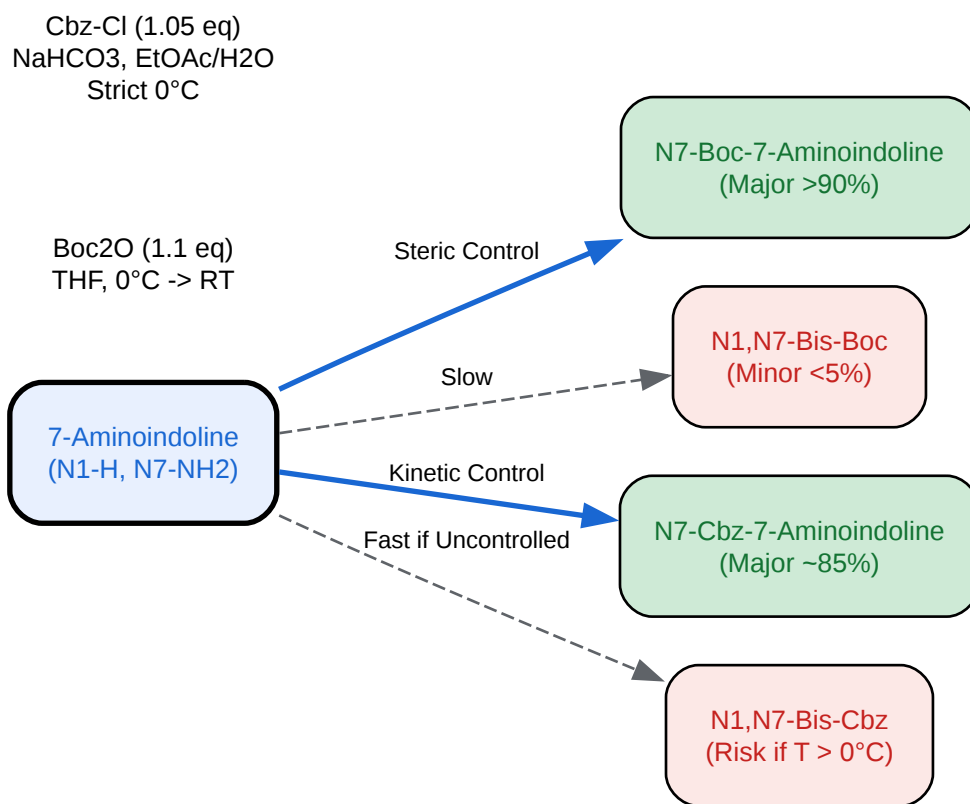

[Click to download full resolution via product page](#)

Caption: Kinetic vs. Steric control pathways. Boc provides inherent steric protection against N1 functionalization, while Cbz requires strict kinetic control.

Diagram 2: Orthogonality & Deprotection Decision Tree

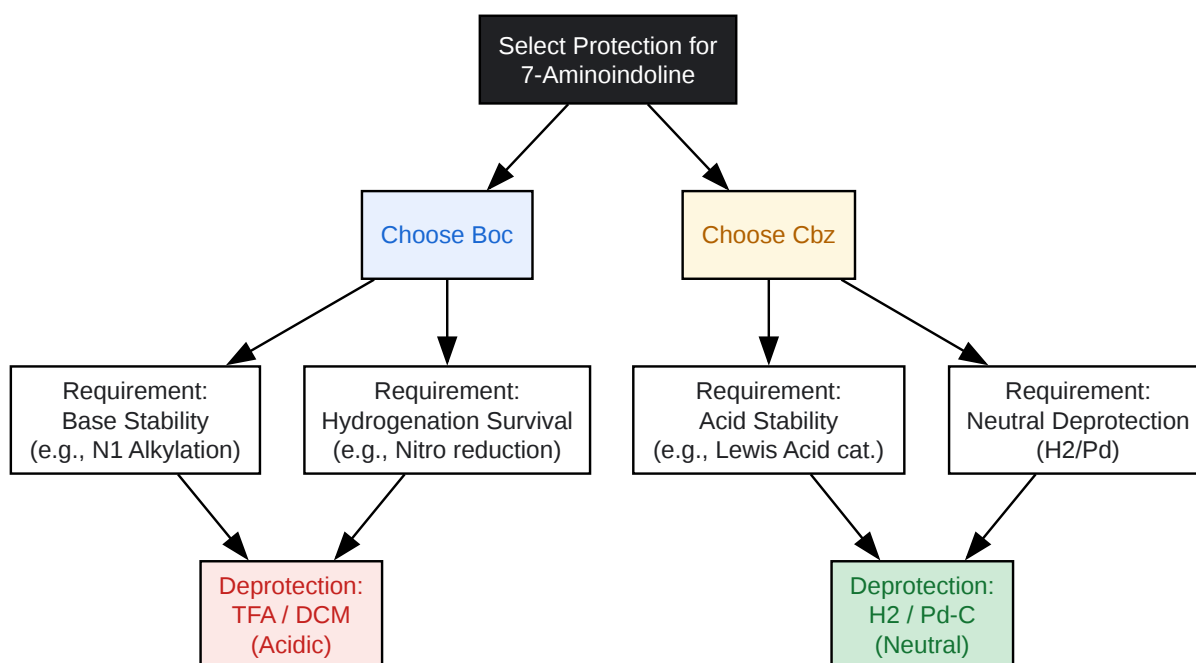

[Click to download full resolution via product page](#)

Caption: Decision tree for selecting protecting groups based on downstream chemical compatibility.

References

- Regioselective Protection of Anilines: Perron, V., et al.[3][4] "A Simple and Efficient Protection Procedure for the Preparation of Mono-N-Boc, N-Cbz Aromatic Amines." *Synthesis*, 2009(02), 283–289.[3] [Link](#)
- Boc Chemistry & Mechanisms: Greene, T. W., & Wuts, P. G. M. *Protective Groups in Organic Synthesis*. Wiley-Interscience.[1] (Standard Reference for Boc/Cbz stability profiles).
- Indoline Scaffold Reactivity: *Beilstein Journal of Organic Chemistry*, "Efficient and regioselective synthesis of amino-indoline derivatives," 2011.[1] [Link](#)
- Cbz Hydrogenolysis Specifics: Felpin, F.-X., & Fouquet, E. "A Useful, Reliable and Safer Protocol for Hydrogenation and Hydrogenolysis." *Chemistry – A European Journal*, 2010, 16(41), 12440–12445. [Link](#)

Need Custom Synthesis?

BenchChem offers custom synthesis for rare earth carbides and specific isotopic labeling.

Email: info@benchchem.com or [Request Quote Online](#).

Sources

- [1. prepchem.com](https://www.prepchem.com) [prepchem.com]
- [2. Thieme E-Books & E-Journals](https://www.thieme-connect.de) [thieme-connect.de]
- [3. A Method for the Selective Protection of Aromatic Amines in the Presence of Aliphatic Amines](https://www.organic-chemistry.org) [organic-chemistry.org]
- [4. Cbz-Protected Amino Groups](https://www.organic-chemistry.org) [organic-chemistry.org]
- To cite this document: BenchChem. [Comparative Guide: Boc vs. Cbz Protection for 7-Aminoindoline[1]]. BenchChem, [2026]. [Online PDF]. Available at: [\[https://www.benchchem.com/product/b1465098/docs#comparative-guide-boc-vs-cbz-protection-for-7-aminoindoline-1\]](https://www.benchchem.com/product/b1465098/docs#comparative-guide-boc-vs-cbz-protection-for-7-aminoindoline-1)

Disclaimer & Data Validity:

The information provided in this document is for Research Use Only (RUO) and is strictly not intended for diagnostic or therapeutic procedures. While BenchChem strives to provide accurate protocols, we make no warranties, express or implied, regarding the fitness of this product for every specific experimental setup.

Technical Support: The protocols provided are for reference purposes. Unsure if this reagent suits your experiment?

Need Industrial/Bulk Grade? [Request Custom Synthesis Quote](#)

BenchChem

Our mission is to be the trusted global source of essential and advanced chemicals, empowering scientists and researchers to drive progress in science and industry.

Contact

Address: 3281 E Guasti Rd

Ontario, CA 91761, United States

Phone: (601) 213-4426

Email: info@benchchem.com

[Contact our Ph.D. Support Team for a compatibility check](#)