

Introduction: The Strategic Imperative for Amine Protection in Heterocyclic Synthesis

Author: BenchChem Technical Support Team. **Date:** May 2026

Compound of Interest

| | |
|----------------|---|
| Compound Name: | <i>Tert-butyl 6-formyl-3,4-dihydroquinoline-1(2H)-carboxylate</i> |
| CAS No.: | 1187933-34-1 |
| Cat. No.: | B1464833 |

[Get Quote](#)

Dihydroquinolines represent a privileged scaffold in medicinal chemistry and materials science, forming the core of numerous pharmaceuticals, agrochemicals, and functional dyes.[1] Their synthesis is a cornerstone of modern heterocyclic chemistry. However, the aniline nitrogen, a key nucleophilic and basic center, often complicates synthetic pathways. Unchecked, its reactivity can lead to a cascade of side reactions, catalyst poisoning, and low yields, derailing an otherwise elegant synthetic design.[2][3]

This guide delves into the strategic application of the tert-butyloxycarbonyl (Boc) protecting group in the synthesis of dihydroquinolines. The Boc group is arguably the most ubiquitous tool for the temporary masking of amine functionality in non-peptide chemistry.[4] Its widespread adoption stems from its unique combination of stability under a wide range of conditions (including basic, nucleophilic, and reductive environments) and its facile, clean removal under specific acidic conditions.[5] We will move beyond a simple description of protection/deprotection, instead focusing on the causality behind its use—how the Boc group actively modulates electronic and steric properties to enable powerful, modern synthetic transformations that would otherwise be unfeasible. This guide is intended for researchers and

drug development professionals seeking to leverage this versatile tool for the efficient and controlled construction of complex dihydroquinoline frameworks.

Part 1: The Mechanistic Influence of the N-Boc Group

The power of the Boc group lies not just in its ability to "mask" the amine, but in how it fundamentally alters the reactivity of the entire aniline scaffold. This alteration is twofold: electronic and steric.

Electronic Modulation: From Reactive Nucleophile to Directed Anion

Upon protection, the aniline nitrogen is converted to a carbamate. The carbonyl group of the Boc moiety exerts a powerful electron-withdrawing effect through resonance, delocalizing the nitrogen's lone pair. This has several critical consequences:

- **Reduced Nucleophilicity and Basicity:** The N-Boc nitrogen is significantly less basic and nucleophilic than the parent aniline. This prevents unwanted reactions such as N-alkylation or protonation under conditions required for other transformations on the molecule.^{[2][3]} It also prevents the nitrogen from coordinating to and poisoning transition metal catalysts (e.g., Palladium, Copper) that are frequently used in modern cyclization strategies.^[6]
- **Enabling Directed ortho-Metalation (DoM):** This is perhaps the most profound strategic advantage conferred by the Boc group in this context. The carbamate functionality is an excellent Directed Metalation Group (DMG).^[7] When an N-Boc aniline is treated with a strong organolithium base (e.g., *s*-BuLi or *t*-BuLi), the base is coordinated by the carbonyl oxygen, delivering the deprotonation event specifically to the adjacent ortho position on the aromatic ring.^{[8][9]} This generates a potent ortho-lithiated nucleophile in situ, which can be trapped with a vast array of electrophiles to install the sidechains necessary for subsequent dihydroquinoline ring formation.^[10] This strategy provides a reliable and regioselective route to 2-substituted anilines that are key precursors for cyclization.

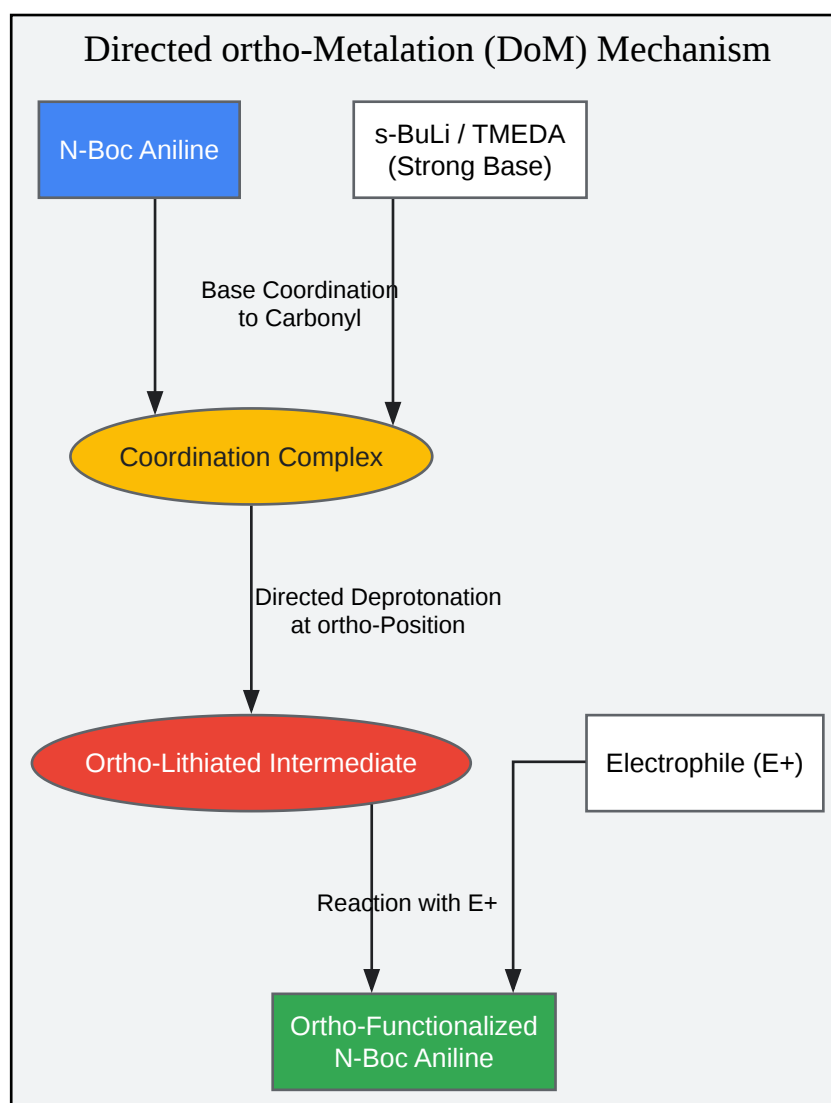

[Click to download full resolution via product page](#)

Fig 1. Mechanism of N-Boc Directed ortho-Metalation.

Steric Influence

The bulky tert-butyl group provides significant steric hindrance around the nitrogen atom. This can be exploited to direct the regioselectivity of reactions, forcing incoming reagents to attack less hindered positions on the molecule. In the context of cyclization precursors, this steric bulk can influence the conformational preferences of the molecule, which in turn can impact the stereochemical outcome of the ring-closing step.

Part 2: Key Synthetic Strategies Enabled by N-Boc Protection

The installation of a Boc group unlocks powerful and reliable synthetic routes for constructing the dihydroquinoline core.

Palladium-Catalyzed Intramolecular Cyclizations

Modern dihydroquinoline synthesis heavily relies on transition-metal catalysis. Palladium-catalyzed reactions, such as intramolecular hydroamination or Heck-type cyclizations, are particularly effective.^[6] In these processes, an N-Boc protected ortho-alkenyl or ortho-alkynyl aniline serves as the key precursor. The Boc group is essential for:

- **Substrate Stability:** It prevents the aniline nitrogen from interfering with the palladium catalyst.
- **Reaction Control:** It ensures that the C-N bond formation occurs in a controlled intramolecular fashion to build the heterocyclic ring.^[11]

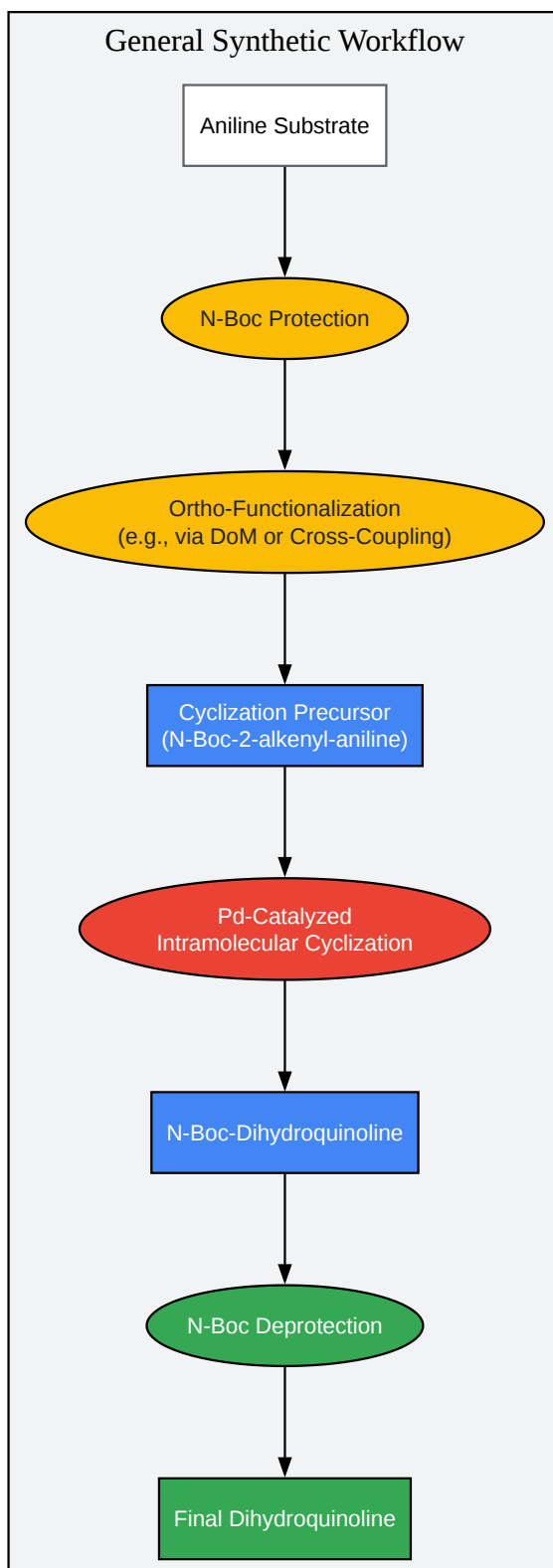

[Click to download full resolution via product page](#)

Fig 2. A common workflow for dihydroquinoline synthesis.

Modified Friedländer Annulation

The classic Friedländer annulation condenses a 2-aminoaryl aldehyde or ketone with a compound containing an active methylene group.[12] While effective, the required 2-aminoaryl carbonyl compounds can be difficult to access. The N-Boc directed ortho-metalation strategy provides a powerful entry point. An N-Boc aniline can be ortho-lithiated and subsequently reacted with an aldehyde or a Weinreb amide to generate the required carbonyl functionality in a protected form, setting the stage for a subsequent cyclization/condensation reaction.[13][14]

Part 3: Field-Proven Experimental Protocols

The following protocols are presented as self-validating systems, providing detailed, step-by-step methodologies for the key transformations discussed.

Protocol 1: General Procedure for N-Boc Protection of an Aniline

This protocol describes a standard, high-yielding method for protecting a primary or secondary aniline using di-tert-butyl dicarbonate (Boc₂O).

Rationale: The reaction proceeds via nucleophilic attack of the amine on one of the Boc₂O carbonyls. A mild base is used to neutralize the protonated amine intermediate and drive the reaction to completion.[4] Dichloromethane (DCM) is a common solvent, but others like THF or solvent-free conditions can also be effective.[15][16]

Materials:

| Reagent | Molar Equiv. | Purpose |
|--|-----------------------|--------------------------|
| Aniline Substrate | 1.0 | Starting Material |
| Di-tert-butyl dicarbonate (Boc ₂ O) | 1.1 | Boc Source |
| Triethylamine (TEA) or DMAP | 1.2 (or 0.1 for DMAP) | Base |

| Dichloromethane (DCM) | - | Solvent |

Procedure:

- **Dissolution:** Dissolve the aniline substrate (1.0 equiv) in anhydrous DCM in a round-bottom flask equipped with a magnetic stir bar.
- **Base Addition:** Add the base (e.g., triethylamine, 1.2 equiv). If using 4-dimethylaminopyridine (DMAP), a catalytic amount (0.1 equiv) is sufficient.[\[17\]](#)
- **Boc₂O Addition:** Cool the mixture to 0 °C in an ice bath. Add Boc₂O (1.1 equiv) portion-wise over 5-10 minutes. Caution: Gas evolution (CO₂) may occur.
- **Reaction:** Remove the ice bath and allow the reaction to stir at room temperature. Monitor the reaction progress by Thin Layer Chromatography (TLC) until the starting material is consumed (typically 1-4 hours).
- **Workup:** Quench the reaction by adding saturated aqueous sodium bicarbonate solution. Transfer the mixture to a separatory funnel and extract the aqueous layer twice with DCM.
- **Purification:** Combine the organic layers, dry over anhydrous sodium sulfate (Na₂SO₄), filter, and concentrate under reduced pressure. The resulting crude product is often pure enough for the next step, but can be further purified by flash column chromatography on silica gel if necessary.

Protocol 2: N-Boc Deprotection under Acidic Conditions

This protocol details the removal of the Boc group to reveal the free amine, a crucial final step in many synthetic sequences.

Rationale: The Boc group is highly labile to strong acids.[\[5\]](#) The mechanism involves protonation of the carbonyl oxygen, followed by the loss of a stable tert-butyl cation and gaseous CO₂, driving the reaction to completion.[\[18\]](#) Trifluoroacetic acid (TFA) is highly effective, but HCl in an organic solvent is also commonly used.[\[17\]](#)[\[19\]](#)

Materials:

| Reagent | Molar Equiv. / Conc. | Purpose |
|----------------------------------|----------------------|--------------------------|
| N-Boc Protected Substrate | 1.0 | Starting Material |
| Trifluoroacetic Acid (TFA) | 10-50% v/v | Acid Catalyst |
| Dichloromethane (DCM) | - | Solvent |

| Optional: Anisole | 1-2 equiv | Cation Scavenger |

Procedure:

- **Dissolution:** Dissolve the N-Boc protected substrate (1.0 equiv) in DCM. If the substrate contains other acid-sensitive groups or electron-rich aromatic rings, add a cation scavenger like anisole or thioanisole (1-2 equiv) to trap the liberated t-butyl cation and prevent side reactions.^[20]
- **Acid Addition:** Cool the solution to 0 °C. Slowly add TFA to achieve a final concentration of 10-50% (v/v). Caution: Vigorous gas evolution (CO₂ and isobutylene) occurs. Ensure adequate ventilation.
- **Reaction:** Stir the reaction at room temperature, monitoring by TLC until deprotection is complete (typically 30 minutes to 2 hours).
- **Workup:** Carefully concentrate the reaction mixture under reduced pressure to remove the excess TFA and DCM.
- **Purification:** Dissolve the residue in a suitable solvent (e.g., ethyl acetate) and wash with a saturated aqueous sodium bicarbonate solution to neutralize any remaining acid. Extract the aqueous layer, combine the organic phases, dry over Na₂SO₄, filter, and concentrate. The resulting free amine can be purified by chromatography or crystallization.

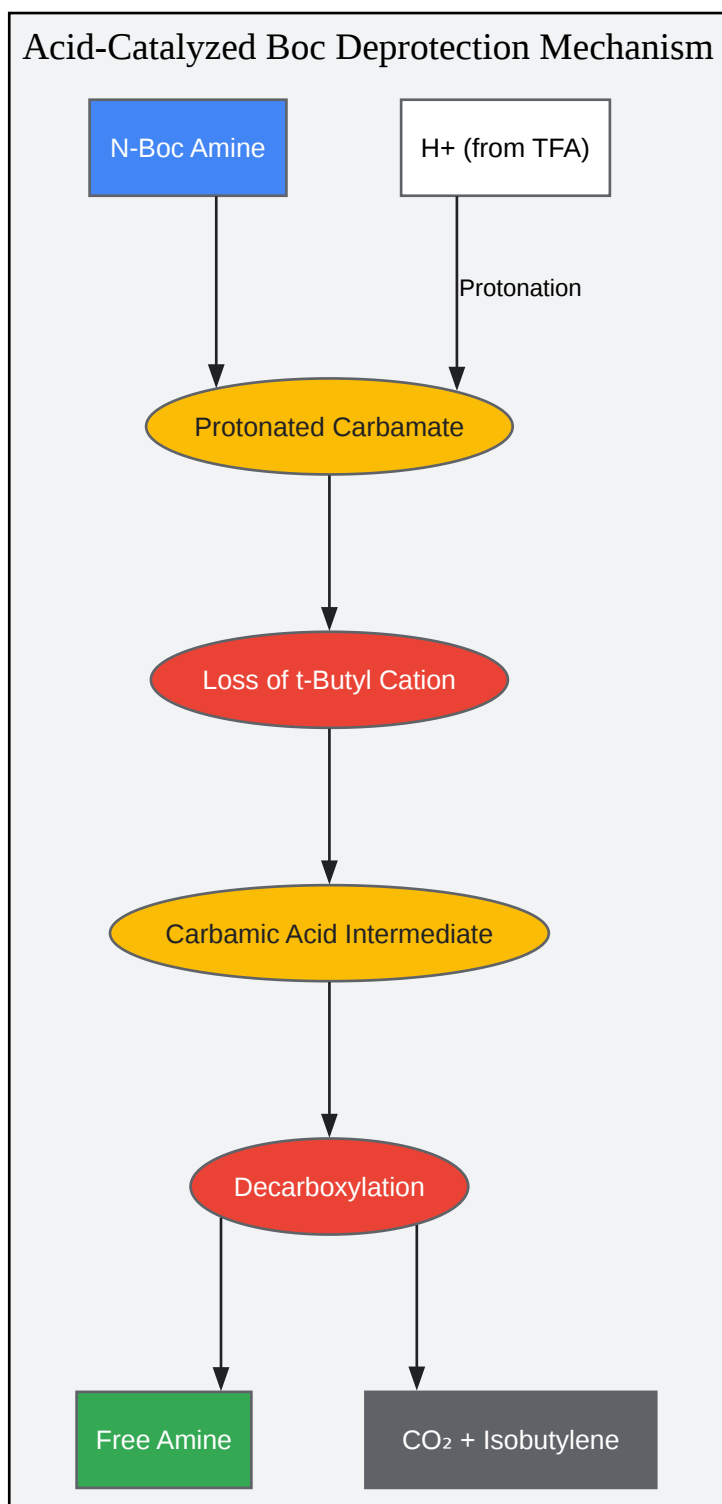

[Click to download full resolution via product page](#)

Fig 3. Mechanism for the acidic removal of the Boc group.

Conclusion

The tert-butyloxycarbonyl group is far more than a simple placeholder in the synthesis of dihydroquinolines. It is an active and powerful control element that fundamentally alters the electronic and steric landscape of the aniline precursor. By pacifying the otherwise reactive amine, it enables the use of sensitive organometallic reagents and transition metal catalysts. Critically, its function as a superb directed metalation group provides a reliable and highly regioselective pathway for the ortho-functionalization of anilines, a key step in constructing the necessary precursors for a variety of powerful cyclization strategies. A thorough understanding of the principles and protocols outlined in this guide empowers the synthetic chemist to strategically leverage the Boc group, transforming challenging synthetic problems into feasible and efficient routes for the construction of valuable dihydroquinoline scaffolds.

References

- Recent Advances for the Synthesis of Dihydroquinolin-2(1H)-ones via Catalytic Annulation of α,β -Unsaturated N-Arylamides. (n.d.). MDPI. [\[Link\]](#)
- Solvent-free, instant, ambient, n-boc protection of amines -A green, recyclable heterogenous acid catalysis. (n.d.). Der Pharma Chemica. [\[Link\]](#)
- Mild deprotection of the N-tert-butyloxycarbonyl (N-Boc) group using oxalyl chloride. (2020). National Institutes of Health (NIH). [\[Link\]](#)
- Efficient deprotection of Boc group in amines and sulfamides using Dawson heteropolyacid catalyst. (n.d.). SciSpace. [\[Link\]](#)
- Boc-Protected Amino Groups. (n.d.). Organic Chemistry Portal. [\[Link\]](#)
- Synthesis of 3-(substitutedthiocarbamide)-aniline derivatives from di-tert-butyl dicarbonate (BoC) protected 3-chloroaniline. (2024). GSC Online Press. [\[Link\]](#)
- tert-Butyloxycarbonyl protecting group. (n.d.). Wikipedia. [\[Link\]](#)
- BOC Deprotection. (n.d.). ACS GCI Pharmaceutical Roundtable. [\[Link\]](#)
- The Critical Role of BOC Protecting Groups in Drug Synthesis. (2025). Shunxiang. [\[Link\]](#)

- Achieving High Ortho Selectivity in Aniline C–H Borylations by Modifying Boron Substituents. (n.d.). ACS Publications. [\[Link\]](#)
- Facile Double-Lithiation of a Transient Urea: Vicarious ortho-Metalation of Aniline Derivatives. (n.d.). Organic Chemistry Portal. [\[Link\]](#)
- Facile Synthesis of Dihydroquinolines via Palladium Catalyzed Sequential Amination and Cyclisation of Morita-Baylis-Hillman Alcohols. (2020). PubMed Central (PMC). [\[Link\]](#)
- BOC protecting groups have become a crucial tool in accelerating the development of innovative drugs. (2025). Nanjing Tengxiang Import & Export Co. Ltd. [\[Link\]](#)
- Synthesis of Quinoline and Dihydroquinoline Embelin Derivatives as Cardioprotective Agents. (n.d.). PubMed Central (PMC). [\[Link\]](#)
- Directed ortho lithiation of phenylcarbamic acid 1,1-dimethylethyl ester (N-BOC-aniline). Revision and improvements. (n.d.). ACS Publications. [\[Link\]](#)
- The development of Friedländer heteroannulation through a single electron transfer and energy transfer pathway using methylene blue (MB+). (n.d.). National Institutes of Health (NIH). [\[Link\]](#)
- A route to 2-substituted tetrahydroquinolines via palladium-catalyzed intramolecular hydroamination of anilino-alkynes. (2007). PubMed. [\[Link\]](#)
- Synthesis and biological evaluation of friedlander annulation approach for the diversity oriented of functionalized quinolines. (n.d.). ResearchGate. [\[Link\]](#)
- Directed Ortho Lithiation of Phenylcarbamic Acid 1,1-Dimethylethyl Ester (N-Boc-aniline). Revision and Improvements. (n.d.). AMiner. [\[Link\]](#)
- Directed ortho lithiation of phenylcarbamic acid 1,1-dimethylethyl ester (N-BOC-aniline). Revision and improvements. (1992). Semantic Scholar. [\[Link\]](#)
- Boc Protecting Group for Amines. (n.d.). Chemistry Steps. [\[Link\]](#)
- BOC Protection and Deprotection. (2025). J&K Scientific LLC. [\[Link\]](#)

- NHC-Cu(I)-Catalyzed Friedländer-Type Annulation of Fluorinated o-Aminophenones with Alkynes on Water: Competitive Base-Catalyzed Dibenzo[b,f][21][22]diazocine Formation. (2017). PubMed. [[Link](#)]

Need Custom Synthesis?

BenchChem offers custom synthesis for rare earth carbides and specific isotopic labeling.

Email: info@benchchem.com or [Request Quote Online](#).

Sources

- 1. Synthesis of Quinoline and Dihydroquinoline Embelin Derivatives as Cardioprotective Agents - PMC [[pmc.ncbi.nlm.nih.gov](https://pubmed.ncbi.nlm.nih.gov)]
- 2. The Critical Role of BOC Protecting Groups in Drug Synthesis | Nanjing Shunxiang Pharmaceutical Technology Co.,Ltd [shunxiangchem.com]
- 3. BOC protecting groups have become a crucial tool in accelerating the development of innovative drugs | Nanjing Tengxiang Import & Export Co. Ltd. [jinxiangchemical.com]
- 4. jk-sci.com [jk-sci.com]
- 5. scispace.com [scispace.com]
- 6. Facile Synthesis of Dihydroquinolines via Palladium Catalyzed Sequential Amination and Cyclisation of Morita-Baylis-Hillman Alcohols - PMC [[pmc.ncbi.nlm.nih.gov](https://pubmed.ncbi.nlm.nih.gov)]
- 7. Achieving High Ortho Selectivity in Aniline C–H Borylations by Modifying Boron Substituents - PMC [[pmc.ncbi.nlm.nih.gov](https://pubmed.ncbi.nlm.nih.gov)]
- 8. pubs.acs.org [pubs.acs.org]
- 9. semanticsscholar.org [semanticsscholar.org]
- 10. Facile Double-Lithiation of a Transient Urea: Vicarious ortho-Metalation of Aniline Derivatives [organic-chemistry.org]
- 11. A route to 2-substituted tetrahydroquinolines via palladium-catalyzed intramolecular hydroamination of anilino-alkynes - PubMed [pubmed.ncbi.nlm.nih.gov]
- 12. The development of Friedländer heteroannulation through a single electron transfer and energy transfer pathway using methylene blue (MB+) - PMC [[pmc.ncbi.nlm.nih.gov](https://pubmed.ncbi.nlm.nih.gov)]
- 13. researchgate.net [researchgate.net]

- 14. NHC-Cu(I)-Catalyzed Friedländer-Type Annulation of Fluorinated o-Aminophenones with Alkynes on Water: Competitive Base-Catalyzed Dibenzo[b,f][1,5]diazocine Formation - PubMed [pubmed.ncbi.nlm.nih.gov]
- 15. derpharmachemica.com [derpharmachemica.com]
- 16. Boc-Protected Amino Groups [organic-chemistry.org]
- 17. tert-Butyloxycarbonyl protecting group - Wikipedia [en.wikipedia.org]
- 18. One moment, please... [chemistrysteps.com]
- 19. Amine Protection / Deprotection [fishersci.co.uk]
- 20. BOC Deprotection - Wordpress [reagents.acsgcipr.org]
- 21. mdpi.com [mdpi.com]
- 22. pdf.benchchem.com [pdf.benchchem.com]
- To cite this document: BenchChem. [Introduction: The Strategic Imperative for Amine Protection in Heterocyclic Synthesis]. BenchChem, [2026]. [Online PDF]. Available at: [https://www.benchchem.com/product/b1464833/docs#introduction-the-strategic-imperative-for-amine-protection-in-heterocyclic-synthesis]

Disclaimer & Data Validity:

The information provided in this document is for Research Use Only (RUO) and is strictly not intended for diagnostic or therapeutic procedures. While BenchChem strives to provide accurate protocols, we make no warranties, express or implied, regarding the fitness of this product for every specific experimental setup.

Technical Support: The protocols provided are for reference purposes. Unsure if this reagent suits your experiment?

Need Industrial/Bulk Grade? [Request Custom Synthesis Quote](#)

BenchChem

Our mission is to be the trusted global source of essential and advanced chemicals, empowering scientists and researchers to drive progress in science and industry.

Contact

Address: 3281 E Guasti Rd

Ontario, CA 91761, United States

Phone: (601) 213-4426

Email: info@benchchem.com

[Contact our Ph.D. Support Team for a compatibility check](#)