

Application Note: Functionalization Strategies for 4-Bromo-6-(o-tolyl)pyrimidine

Author: BenchChem Technical Support Team. **Date:** May 2026

Compound of Interest

Compound Name: 4-Bromo-6-(o-tolyl)pyrimidine

CAS No.: 1086382-25-3

Cat. No.: B1463224

[Get Quote](#)

Introduction & Scope

This application note details the experimental protocols for the functionalization of **4-Bromo-6-(o-tolyl)pyrimidine**, a critical scaffold in the synthesis of kinase inhibitors (specifically p38 MAP kinase and PLK1 pathways) and biaryl heterocycles.

The pyrimidine core is highly electron-deficient, rendering the C4-bromide bond labile to both Palladium-catalyzed cross-coupling and Nucleophilic Aromatic Substitution (

). However, the presence of the 6-(o-tolyl) group introduces a specific steric and electronic environment that distinguishes this substrate from simpler analogs. The ortho-methyl group on the pendant phenyl ring forces a non-planar conformation (atropisomerism potential), improving solubility in organic solvents but requiring specific catalytic systems to prevent protodebromination during cross-coupling.^[1]

Core Chemical Properties^{[1][2][3][4][5][6][7]}

Property	Value / Description
Molecular Formula	
Molecular Weight	249.11 g/mol
Physical State	Off-white to pale yellow solid
Solubility	Soluble in DCM, THF, DMSO; Sparingly soluble in MeOH; Insoluble in Water
Key Reactivity	Electrophilic attack at C4; Coordination at N1/N3
Storage	2-8°C, under inert atmosphere (Ar/N2)

Reaction Workflow Overview

The following diagram illustrates the divergent synthetic pathways accessible from the parent scaffold.

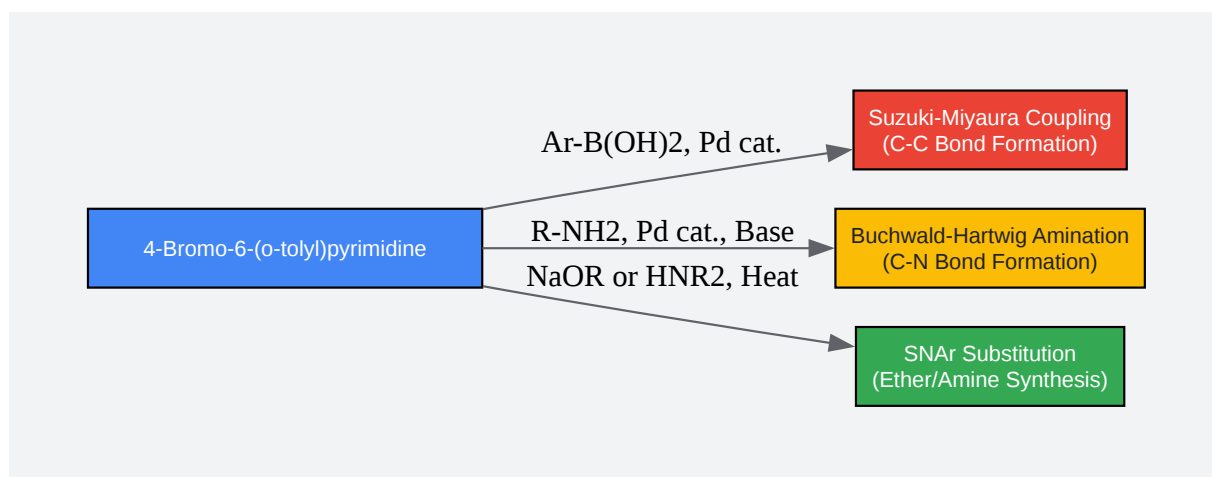

[Click to download full resolution via product page](#)

Figure 1: Divergent synthetic pathways for **4-Bromo-6-(o-tolyl)pyrimidine** functionalization.

Protocol A: Suzuki-Miyaura Cross-Coupling

Objective: Installation of aryl/heteroaryl groups at the C4 position. Challenge: The electron-deficient pyrimidine ring can promote rapid oxidative addition, but competitive protodebromination (replacement of Br with H) is a common side reaction if the transmetalation step is slow.[1]

Optimized Reagents

- Catalyst:

(Preferred for stability) or

with XPhos (for sterically demanding boronic acids).[1]

- Solvent System: 1,4-Dioxane / Water (4:1).[1] The biphasic system is crucial for inorganic base solubility.

- Base:

(Standard) or

(For difficult substrates).[1]

Step-by-Step Procedure

- Setup: Flame-dry a 25 mL round-bottom flask equipped with a magnetic stir bar and a reflux condenser. Cool under a stream of Argon.
- Charging: Add **4-Bromo-6-(o-tolyl)pyrimidine** (1.0 equiv, 1.0 mmol, 249 mg) and the Aryl Boronic Acid (1.2 equiv).
- Solvent & Base: Add 1,4-Dioxane (8 mL) and degassed Water (2 mL). Add (2.5 equiv).[1]
- Degassing (Critical): Sparge the mixture with Argon for 10 minutes. Oxygen presence leads to homocoupling of the boronic acid and catalyst deactivation.
- Catalyst Addition: Quickly add (0.05 equiv, 5 mol%).[1]

- Reaction: Heat the mixture to 90°C for 4–12 hours. Monitor by TLC (Hexane/EtOAc 4:1) or LC-MS.
 - Checkpoint: The product usually fluoresces blue/purple under UV (254/365 nm).
- Workup: Cool to Room Temperature (RT). Dilute with EtOAc (20 mL) and wash with Brine (2 x 10 mL).[1] Dry organic layer over , filter, and concentrate.[1]
- Purification: Flash column chromatography (Silica gel). Elute with a gradient of 0-30% EtOAc in Hexanes.

Protocol B: Nucleophilic Aromatic Substitution ()

Objective: Introduction of amines or alkoxides without transition metals.[1] Mechanism: The reaction proceeds via a Meisenheimer complex.[2][3][4] The electron-withdrawing nature of the pyrimidine nitrogens activates the C4 position.

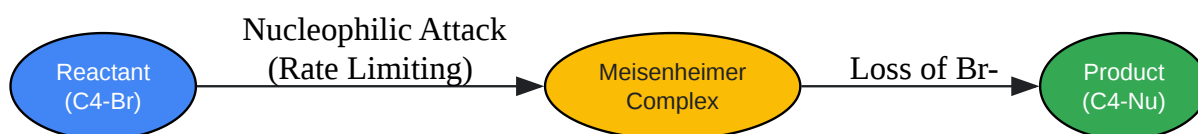

[Click to download full resolution via product page](#)

Figure 2:

mechanism.[1][5][6] The rate is accelerated by the electron-poor pyrimidine core.

Step-by-Step Procedure (Amination)

- Solvent Choice: Use DMSO or DMF (Anhydrous). Protic solvents (EtOH) can be used but may require higher temperatures or sealed tubes.[1]
- Stoichiometry:
 - Substrate: 1.0 equiv

- Amine (Nucleophile): 1.5 – 2.0 equiv[1]
- Base: DIPEA (N,N-Diisopropylethylamine) 2.5 equiv.[1]
- Execution:
 - Dissolve **4-Bromo-6-(o-tolyl)pyrimidine** in DMSO (0.2 M concentration).
 - Add DIPEA followed by the amine.
 - Stir at 80°C for 2-6 hours.
 - Note: If using a volatile amine, use a sealed pressure vial.[1]
- Quench: Pour the reaction mixture into crushed ice/water. The product often precipitates as a solid.
- Isolation: Filter the solid. If no precipitate forms, extract with EtOAc.[1]
- Purification: Recrystallization from Ethanol is often sufficient; otherwise, use column chromatography (DCM/MeOH gradients).[1]

Analytical Data & Validation

To ensure the integrity of the reaction, compare the isolated product against these expected trends:

Technique	Expected Observation
¹ H NMR	Reactant: C2-H singlet ~9.0 ppm; C5-H singlet ~7.8 ppm; o-Tolyl Methyl ~2.4 ppm. Product: Loss of symmetry if coupling is non-symmetric. Shift in C5-H signal.[7]
LC-MS	Reactant: Distinct Br isotope pattern (M and M+2 peaks of equal height). Product: Disappearance of Br pattern; appearance of Product Mass (M+H).
TLC	The bromide is relatively non-polar. Coupled products (especially amines) will have significantly lower R _f values.[1]

Troubleshooting Guide

- Problem: Low conversion in Suzuki Coupling.
 - Root Cause:[1][5][8][9] Steric hindrance of the o-tolyl group affecting catalyst approach, or catalyst poisoning by pyrimidine nitrogens.[1]
 - Solution: Switch to SPhos-Pd-G2 or XPhos-Pd-G2 precatalysts. These bulky ligands create an active catalytic pocket that facilitates coupling on sterically crowded heterocycles.
- Problem: Hydrolysis to 4-hydroxy-6-(o-tolyl)pyrimidine.
 - Root Cause:[1][5][8][9] Wet solvents in
or excessive hydroxide concentration.
 - Solution: Ensure anhydrous conditions; use DIPEA instead of inorganic bases for

Safety & Handling

- Hazard Identification: **4-Bromo-6-(o-tolyl)pyrimidine** is an organobromide. Treat as an irritant (H315, H319).^[1]^[10] Avoid inhalation of dust.
- Waste Disposal: Aqueous waste from Suzuki couplings contains Palladium residues and must be segregated into heavy metal waste streams.
- Reactive Hazards: Avoid strong oxidizing agents.

References

- Suzuki-Miyaura Coupling of 4,6-Dihalopyrimidines
 - Synthesis of 4-Aryl and Unsymmetrical 4,6-Diarylpyrimidines by the Suzuki-Miyaura Cross-Coupling Reaction.
 - Source: ResearchG
- Mechanistic Insight into Pyrimidine Reactivity
 - Site-selective Suzuki–Miyaura coupling of heteroaryl halides – understanding the trends for pharmaceutically important classes.
 - Source: Chemical Science (RSC).^[1]
- General Nucleophilic Aromatic Substitution Protocols
 - Nucleophilic Aromatic Substitution: Introduction and Mechanism.
 - Source: Master Organic Chemistry.
- Related Scaffold Synthesis (Macitentan Analogues)
 - The Discovery of Macitentan, an Orally Active, Potent Dual Endothelin Receptor Antagonist.^[1]^[11] (Demonstrates pyrimidine ether synthesis via

).
 - Source: Journal of Medicinal Chemistry (ACS).^[1]
 - ^[1]

Need Custom Synthesis?

BenchChem offers custom synthesis for rare earth carbides and specific isotopic labeling.

Email: info@benchchem.com or [Request Quote Online](#).

Sources

- 1. Novel Aminopyrimidine-2,4-diones, 2-Thiopyrimidine-4-ones, and 6-Arylpteridines as Dual-Target Inhibitors of BRD4/PLK1: Design, Synthesis, Cytotoxicity, and Computational Studies - PMC [[pmc.ncbi.nlm.nih.gov](https://pubmed.ncbi.nlm.nih.gov/)]
- 2. m.youtube.com [m.youtube.com]
- 3. Concerted Nucleophilic Aromatic Substitutions - PMC [[pmc.ncbi.nlm.nih.gov](https://pubmed.ncbi.nlm.nih.gov/)]
- 4. masterorganicchemistry.com [masterorganicchemistry.com]
- 5. pubs.acs.org [pubs.acs.org]
- 6. Nucleophilic aromatic substitution - Wikipedia [en.wikipedia.org]
- 7. 4-Bromo-6-[(1-methylethyl)thio]pyrimidine | C₇H₉BrN₂S | CID 44607675 - PubChem [pubchem.ncbi.nlm.nih.gov]
- 8. researchgate.net [researchgate.net]
- 9. mdpi.com [mdpi.com]
- 10. 4-Bromo-6-methylpyridin-3-ol | C₆H₆BrNO | CID 58092719 - PubChem [pubchem.ncbi.nlm.nih.gov]
- 11. researchgate.net [researchgate.net]
- To cite this document: BenchChem. [Application Note: Functionalization Strategies for 4-Bromo-6-(o-tolyl)pyrimidine]. BenchChem, [2026]. [Online PDF]. Available at: [<https://www.benchchem.com/product/b1463224/docs#application-note-functionalization-strategies-for-4-bromo-6-o-tolyl-pyrimidine>]

Disclaimer & Data Validity:

The information provided in this document is for Research Use Only (RUO) and is strictly not intended for diagnostic or therapeutic procedures. While BenchChem strives to provide accurate protocols, we make no warranties, express or implied, regarding the fitness of this product for every specific experimental setup.

Technical Support: The protocols provided are for reference purposes. Unsure if this reagent suits your experiment?

Need Industrial/Bulk Grade? [Request Custom Synthesis Quote](#)

BenchChem

Our mission is to be the trusted global source of essential and advanced chemicals, empowering scientists and researchers to drive progress in science and industry.

Contact

Address: 3281 E Guasti Rd
Ontario, CA 91761, United States
Phone: (601) 213-4426
Email: info@benchchem.com

[Contact our Ph.D. Support Team for a compatibility check](#)