

Advanced Characterization of Phenoxyethylamine Derivatives: MS Fragmentation Dynamics and Platform Comparison

Author: BenchChem Technical Support Team. **Date:** May 2026

Compound of Interest

Compound Name: [2-(4-
Ethylphenoxy)ethyl]methylamine
hydrochloride

CAS No.: 1269127-58-3

Cat. No.: B1463323

[Get Quote](#)

Executive Summary

Phenoxyethylamine (POEA) derivatives represent a distinct chemical scaffold often encountered in medicinal chemistry (as bioisosteres of phenethylamines) and increasingly in forensic toxicology as novel psychoactive substance (NPS) precursors or impurities. While structurally analogous to phenethylamines (PEAs), the introduction of the ether linkage (

) fundamentally alters the fragmentation kinetics under mass spectrometry.

This guide provides a technical comparison of the fragmentation patterns of phenoxyethylamine derivatives against their carbon-linked analogs (phenethylamines). It synthesizes data from Electron Ionization (EI) and Electrospray Ionization (ESI) platforms to establish a self-validating identification workflow.

Structural Logic & Mechanistic Divergence

The core challenge in analyzing phenoxyethylamines is distinguishing them from their isobaric phenethylamine counterparts (e.g., 2-phenoxyethylamine vs. tyramine or

-hydroxy-phenethylamines).

The Ether Linkage Effect

In phenethylamines (

), the benzylic carbon-carbon bond is relatively stable, directing fragmentation primarily toward

-cleavage at the nitrogen. In phenoxyethylamines (

), the ether oxygen introduces two critical changes:

- **Inductive Effect:** The oxygen atom destabilizes the adjacent alkyl chain, altering the energetics of the -cleavage.
- **Charge Localization:** The lone pairs on the oxygen provide a secondary site for charge localization (especially in ESI), competing with the amine nitrogen.

Pathway Visualization

The following diagram illustrates the divergent fragmentation pathways between the POEA and PEA scaffolds.

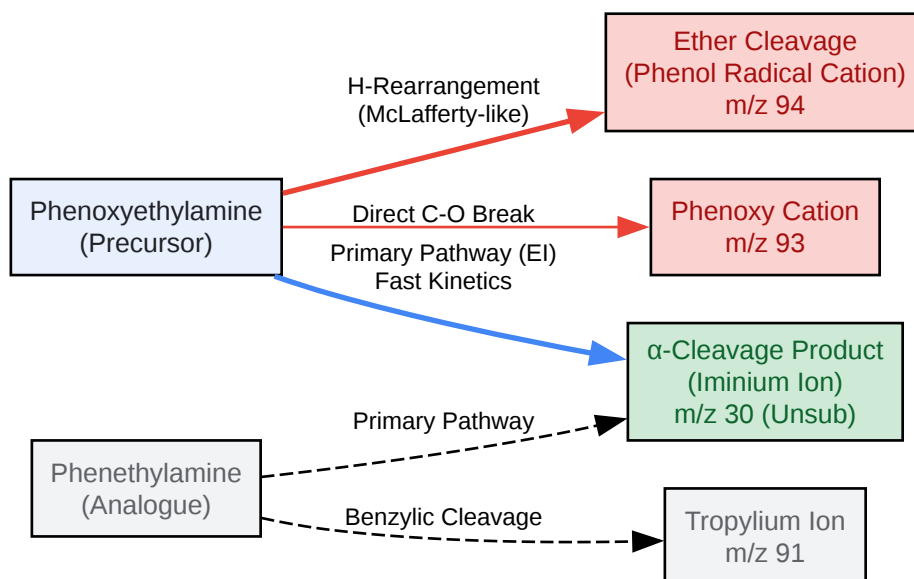

[Click to download full resolution via product page](#)

Figure 1: Divergent fragmentation pathways. Note the diagnostic shift from Tropylium (m/z 91) in PEAs to Phenol/Phenoxy species (m/z 94/93) in POEAs.

Electron Ionization (EI) Characteristics[2]

Under hard ionization (70 eV), POEA derivatives exhibit a "fingerprint" distinct from PEAs.

Primary Fragmentation: The Amine Series

Like PEAs, the base peak in the EI spectrum of an unsubstituted phenoxyethylamine is typically generated by

-cleavage adjacent to the nitrogen atom.

- Mechanism: Radical site initiation at the nitrogen lone pair triggers homolytic cleavage of the bond.
- Diagnostic Ion:
(
).

- Substituent Shift:
 - N-methyl derivative
 - N-ethyl derivative
 - -methyl derivative (e.g., phenoxy-amphetamine analog)

Secondary Fragmentation: The Ether Series (Differentiation Key)

This is the critical differentiator. While PEAs form the tropylium ion (

,

), POEAs undergo cleavage at the ether linkage.

- Phenol Radical Cation (): Formed via a hydrogen rearrangement (often from the -carbon or amine) to the oxygen, followed by cleavage. This is often the second most abundant ion.
- Phenoxy Cation (): Direct heterolytic cleavage of the bond.
- Arene Cation (): Loss of the oxygen from the phenoxy group (less common, usually low abundance).

Comparative Data: Unsubstituted Isobaric Pairs

Compound	Molecular Formula	MW	Base Peak (EI)	Diagnostic Arene Ion
2-Phenoxyethylamine		137		()
Tyramine (p-Hydroxy-PEA)		137		(Hydroxybenzyl)
N-Hydroxy-PEA		137		(Tropylium)

Electrospray Ionization (ESI-MS/MS) Dynamics

In LC-MS/MS (Soft Ionization), the protonated molecule

is the precursor. Fragmentation (CID) is driven by charge migration.

Protonation Site Competition

The ether oxygen is weakly basic compared to the amine nitrogen. Therefore, the precursor is almost exclusively protonated at the amine:

Collision Induced Dissociation (CID) Pathways[3]

- Neutral Loss of Ammonia (): Common in aliphatic amines. The precursor loses to form a phenoxy-ethyl cation ().
 - Observation: Transition

- Ether Cleavage (Phenol Formation): Under higher collision energies, the ether bond cleaves. The charge may be retained on the alkyl chain (forming small aliphatic ions) or the aromatic ring depending on substitution.
 - Key Transition:

(Phenol radical cation is rare in ESI, usually seen as protonated phenol if charge retention favors the ring).

Experimental Protocols

To ensure reproducibility and valid differentiation, the following protocols are recommended.

Protocol A: GC-MS Differentiation (EI)

Objective: Distinguish POEA derivatives from PEA isomers using characteristic ion ratios.

- Sample Prep: Dissolve 1 mg sample in 1 mL Methanol. No derivatization required for basic profiling, though TFA-derivatization improves peak shape.
- Inlet: Split 20:1, 250°C.
- Column: Rxi-5ms or equivalent (30m x 0.25mm, 0.25µm).
- Oven Program: 80°C (1 min)

20°C/min

300°C (hold 3 min).
- MS Parameters: Source 230°C, Quad 150°C, Scan 40-400 amu.
- Data Validation:
 - Check for

(confirming primary amine).[1]
 - Check ratio of

vs

.

- o Rule: If

relative abundance and

, assign as Phenoxy-derivative. If

is dominant, assign as Phenethyl-derivative.

Protocol B: LC-MS/MS Screening (ESI)

Objective: High-sensitivity detection in biological matrices.

- Mobile Phase:
 - o A: Water + 0.1% Formic Acid.
 - o B: Acetonitrile + 0.1% Formic Acid.
- Gradient: 5% B to 95% B over 10 mins. C18 Column.
- MS Source: ESI Positive Mode. Capillary 3.5 kV.
- MRM Transitions (for 2-phenoxyethylamine):
 - o Quantifier:
(Loss of
).
 - o Qualifier:
(Aromatic ring, high energy).
 - o Qualifier:
(Phenol formation).

Summary of Characteristic Ions

The table below summarizes the expected mass shifts for common derivatives.

Derivative Type	Structure Modification	EI Base Peak ()	EI Diagnostic Ether Peak	ESI Precursor
Unsubstituted				138
N-Methyl				152
N-Ethyl				166
4-Chloro-Ring				172/174
4-Methoxy-Ring				168
-Methyl				152

Diagram: Analytical Decision Tree

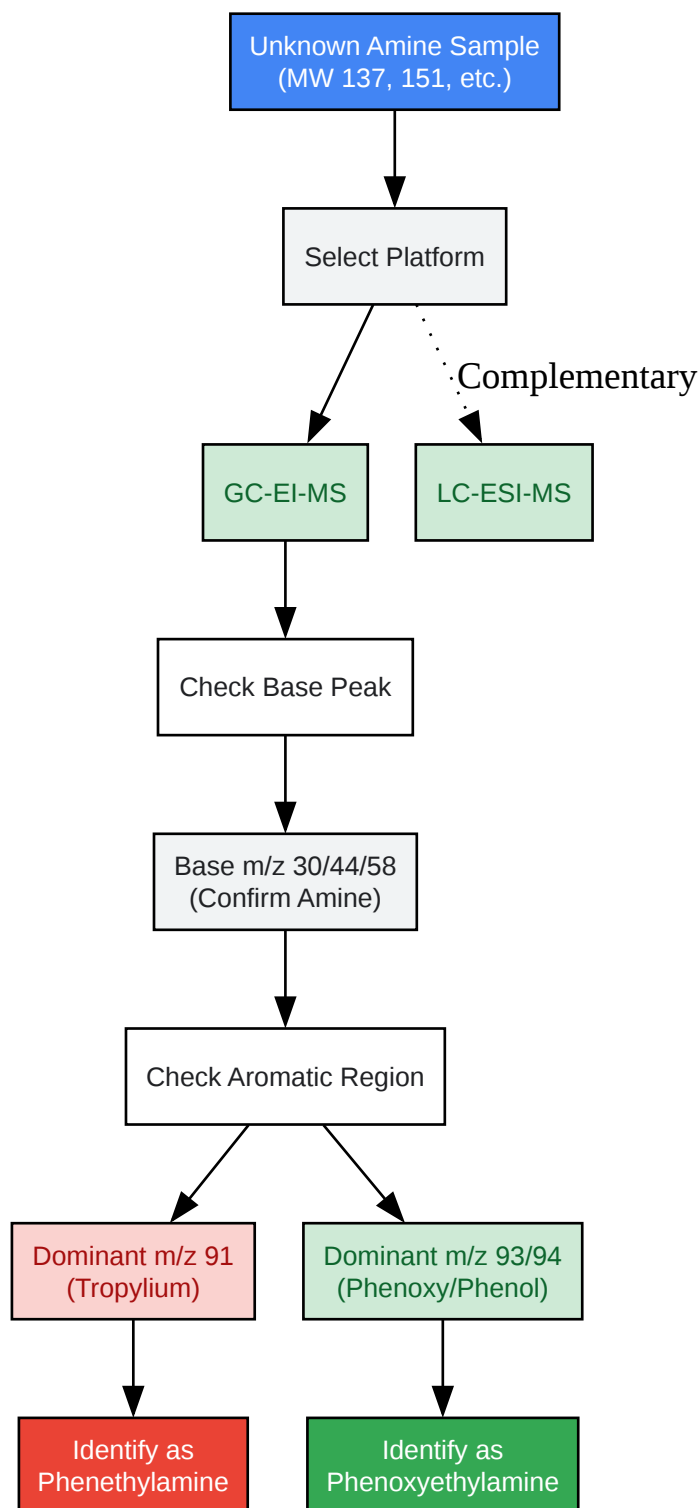

[Click to download full resolution via product page](#)

Figure 2: Decision tree for differentiating phenoxyethylamines from phenethylamines using EI-MS.

References

- National Center for Biotechnology Information (NCBI). PubChem Compound Summary for CID 15651, 2-Phenoxyethanamine. PubChem. Available at: [\[Link\]](#)
- Awad, T., Clark, C. R., & DeRuiter, J. (2008). GC-IRD Analysis of Regioisomeric Substituted Phenethylamines of Mass Spectral Equivalence. *Chromatography Today*. Available at: [\[Link\]](#)
- Sekuła, K., Wrzesień-Tokarczyk, W., & Zuba, D. (2019). Analysis of the fragmentation of new-type phenethylamine derivatives from the NBOME and NBF groups under electrospray ionization conditions. *Problems of Forensic Sciences*. Available at: [\[Link\]](#)

Need Custom Synthesis?

BenchChem offers custom synthesis for rare earth carbides and specific isotopic labeling.

Email: info@benchchem.com or [Request Quote Online](#).

Sources

- 1. [mdpi.com](https://www.mdpi.com) [[mdpi.com](https://www.mdpi.com)]
- To cite this document: BenchChem. [Advanced Characterization of Phenoxyethylamine Derivatives: MS Fragmentation Dynamics and Platform Comparison]. BenchChem, [2026]. [Online PDF]. Available at: [\[https://www.benchchem.com/product/b1463323/docs#advanced-characterization-of-phenoxyethylamine-derivatives-ms-fragmentation-dynamics-and-platform-comparison\]](https://www.benchchem.com/product/b1463323/docs#advanced-characterization-of-phenoxyethylamine-derivatives-ms-fragmentation-dynamics-and-platform-comparison)

Disclaimer & Data Validity:

The information provided in this document is for Research Use Only (RUO) and is strictly not intended for diagnostic or therapeutic procedures. While BenchChem strives to provide accurate protocols, we make no warranties, express or implied, regarding the fitness of this product for every specific experimental setup.

Technical Support: The protocols provided are for reference purposes. Unsure if this reagent suits your experiment?

Need Industrial/Bulk Grade? [Request Custom Synthesis Quote](#)

BenchChem

Our mission is to be the trusted global source of essential and advanced chemicals, empowering scientists and researchers to drive progress in science and industry.

Contact

Address: 3281 E Guasti Rd
Ontario, CA 91761, United States
Phone: (601) 213-4426
Email: info@benchchem.com

[Contact our Ph.D. Support Team for a compatibility check](#)