

4-Bromo-2-(furan-3-yl)pyrimidine: Structural Data & Synthesis Guide

Author: BenchChem Technical Support Team. **Date:** April 2026

Compound of Interest

Compound Name: 4-Bromo-2-(furan-3-yl)pyrimidine

CAS No.: 1086381-95-4

Cat. No.: B1463233

[Get Quote](#)

Chemical Identity & Computed Data

This compound is a 2,4-disubstituted pyrimidine featuring a furan-3-yl group at the C2 position and a bromine atom at the C4 position. This specific regiochemistry is less common than the 4-(furan-3-yl) isomer due to the natural reactivity of the pyrimidine ring, making its synthesis a precise exercise in regiocontrol.

Property	Data
IUPAC Name	4-Bromo-2-(furan-3-yl)pyrimidine
Molecular Formula	C ₈ H ₅ BrN ₂ O
Molecular Weight	225.04 g/mol
Canonical SMILES	BrC1=NC(C2=COC=C2)=NC=C1
Isomeric SMILES	BrC1=NC(=NC=C1)C2=COC=C2
InChI String	InChI=1S/C8H5BrN2O/c9-7-1-2-10-8(11-7)6-3-4-12-5-6/h1-5H
LogP (Predicted)	~2.31
TPSA	39.0 Å ²

Structural Analysis & Regioselectivity Challenge

The synthesis of **4-Bromo-2-(furan-3-yl)pyrimidine** presents a classic regioselectivity problem in heterocyclic chemistry.

- **The Problem:** In 2,4-dihalopyrimidines (e.g., 2,4-dichloropyrimidine), the C4 position is significantly more reactive towards nucleophilic aromatic substitution (S_NAr) and palladium-catalyzed cross-couplings (Suzuki-Miyaura) due to the para-like electron deficiency relative to N1.
- **The Consequence:** Direct Suzuki coupling of 2,4-dibromopyrimidine with furan-3-boronic acid predominantly yields the 4-(furan-3-yl)-2-bromopyrimidine isomer (the "wrong" isomer).
- **The Solution:** To obtain the 2-(furan-3-yl)-4-bromo isomer, one must employ a De Novo Synthesis (Pinner-type cyclization) or a blocking group strategy. The De Novo route is preferred for scalability and purity.

Diagram 1: The Regioselectivity Challenge

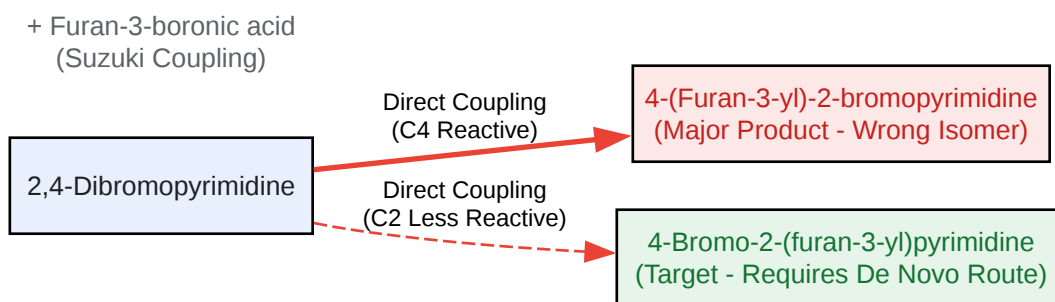

[Click to download full resolution via product page](#)

Caption: Direct Suzuki coupling favors the C4-substituted product. The target C2-substituted isomer requires an alternative synthetic strategy.

Synthesis Protocol: De Novo Cyclization Route

This protocol constructs the pyrimidine ring around the furan moiety, ensuring the furan is fixed at the C2 position before the bromine is introduced at C4.

Step 1: Preparation of Furan-3-carboxamide Hydrochloride

- Reagents: Furan-3-carbonitrile, Sodium Methoxide (NaOMe), Ammonium Chloride (NH₄Cl).
- Mechanism: Pinner reaction followed by amidine formation.
- Procedure:
 - Dissolve furan-3-carbonitrile (1.0 eq) in anhydrous methanol.
 - Add NaOMe (0.1 eq) and stir at RT for 3-6 h to form the imidate intermediate.
 - Add NH₄Cl (1.1 eq) and reflux for 12 h.
 - Cool, filter the precipitate (NH₄Cl), and concentrate the filtrate to obtain crude furan-3-carboxamide hydrochloride.

Step 2: Cyclization to 2-(Furan-3-yl)pyrimidin-4(3H)-one

- Reagents: Furan-3-carboxamide HCl, Ethyl Propiolate (or Methyl 3-methoxyacrylate), NaOEt.

- Procedure:
 - Dissolve furan-3-carboxamidine HCl (1.0 eq) and Ethyl Propiolate (1.1 eq) in anhydrous ethanol.
 - Add NaOEt (2.5 eq) dropwise at 0°C.
 - Reflux the mixture for 8-16 h. The amidine condenses with the alkyne ester to close the pyrimidine ring.
 - Acidify with acetic acid to precipitate the product.
 - Filter and dry to yield 2-(furan-3-yl)pyrimidin-4(3H)-one.

Step 3: Bromination (Aromatization)

- Reagents: Phosphorus Oxybromide (POBr₃) or POCl₃/PBr₃.
- Procedure:
 - Suspend 2-(furan-3-yl)pyrimidin-4(3H)-one (1.0 eq) in anhydrous toluene or acetonitrile.
 - Add POBr₃ (1.5 eq) and catalytic N,N-dimethylaniline.
 - Heat to 80-100°C for 2-4 h. The C4-carbonyl oxygen is converted to a leaving group and displaced by bromide.
 - Quench: Pour onto ice/water carefully (exothermic).
 - Extraction: Extract with EtOAc, wash with NaHCO₃, dry over MgSO₄.
 - Purification: Flash chromatography (Hexane/EtOAc) to yield pure **4-Bromo-2-(furan-3-yl)pyrimidine**.

Diagram 2: De Novo Synthesis Workflow

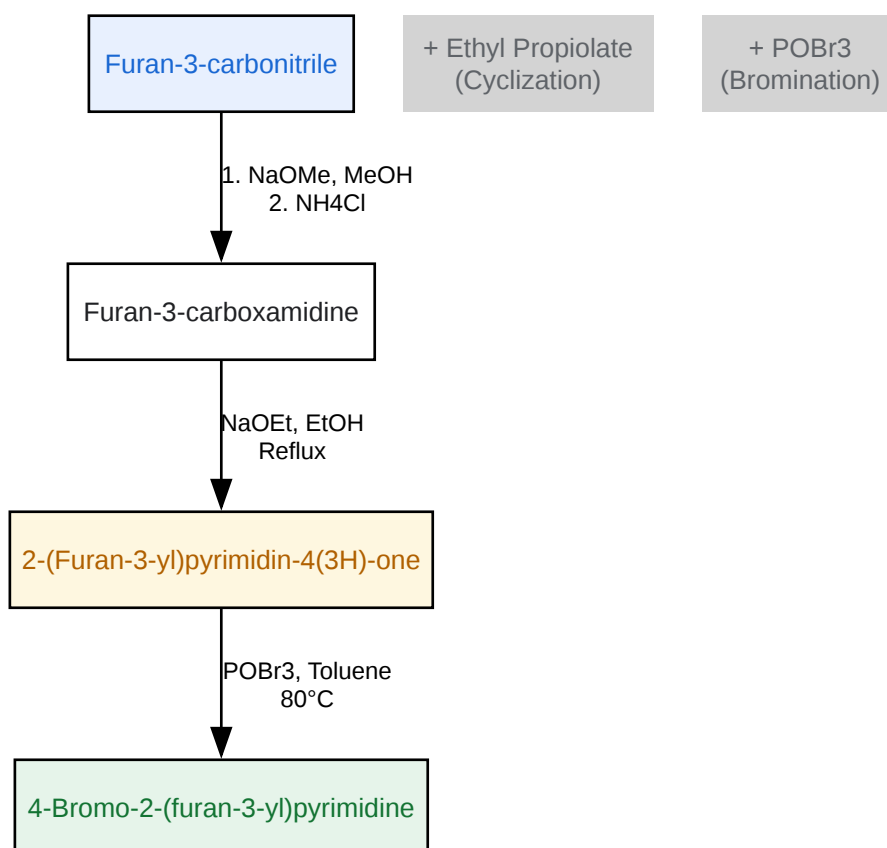

[Click to download full resolution via product page](#)

Caption: Step-wise construction of the pyrimidine ring ensures correct regiochemistry.

Applications in Drug Discovery

The **4-Bromo-2-(furan-3-yl)pyrimidine** scaffold is a versatile intermediate for generating libraries of bioactive compounds.

- **S_NAr Diversification (C4):** The bromine at C4 is highly activated by the adjacent nitrogen atoms. It can be readily displaced by primary and secondary amines, alkoxides, or thiols.
 - Example: Reaction with morpholine or piperazine yields 4-amino-2-(furan-3-yl)pyrimidines, common motifs in adenosine receptor antagonists (e.g., A2A).
- **Suzuki Coupling (C4):** The C4-Br bond can undergo palladium-catalyzed coupling with aryl or heteroaryl boronic acids to create 2,4-biaryl pyrimidines.

- Note: Since the furan is already installed at C2, this allows for the independent optimization of the C4 substituent.

References

- Brown, D. J. (2009). The Pyrimidines. Wiley-Interscience. (Standard reference for Pinner synthesis and pyrimidine reactivity).
- Schomaker, J. M., & Delia, T. J. (2001). Arylation of Halogenated Pyrimidines via a Suzuki Coupling Reaction.[1][2][3][4] The Journal of Organic Chemistry, 66(21), 7125–7128. [Link](#) (Discusses regioselectivity of Suzuki coupling in pyrimidines).
- Gomtsyan, A. (2012). Adenosine A3 receptor antagonists: current status and future perspectives. Expert Opinion on Investigational Drugs, 21(6), 797-809. (Illustrates the utility of furan-pyrimidine scaffolds).
- PubChem Compound Summary. (2024). 4-Bromopyrimidine Derivatives. National Center for Biotechnology Information. [Link](#) (General source for computed properties).

Need Custom Synthesis?

BenchChem offers custom synthesis for rare earth carbides and specific isotopic labeling.

Email: info@benchchem.com or [Request Quote Online](#).

Sources

- [1. semanticscholar.org](https://www.semanticscholar.org) [[semanticscholar.org](https://www.semanticscholar.org)]
- [2. researchgate.net](https://www.researchgate.net) [[researchgate.net](https://www.researchgate.net)]
- [3. One-pot Double Suzuki Couplings of Dichloropyrimidines - PMC](https://pubmed.ncbi.nlm.nih.gov/) [[pmc.ncbi.nlm.nih.gov](https://pubmed.ncbi.nlm.nih.gov/)]
- [4. mdpi.com](https://www.mdpi.com) [[mdpi.com](https://www.mdpi.com)]
- To cite this document: BenchChem. [4-Bromo-2-(furan-3-yl)pyrimidine: Structural Data & Synthesis Guide]. BenchChem, [2026]. [Online PDF]. Available at: [<https://www.benchchem.com/product/b1463233/docs#4-bromo-2-furan-3-yl-pyrimidine-structural-data-synthesis-guide>]

Disclaimer & Data Validity:

The information provided in this document is for Research Use Only (RUO) and is strictly not intended for diagnostic or therapeutic procedures. While BenchChem strives to provide accurate protocols, we make no warranties, express or implied, regarding the fitness of this product for every specific experimental setup.

Technical Support: The protocols provided are for reference purposes. Unsure if this reagent suits your experiment?

Need Industrial/Bulk Grade? [Request Custom Synthesis Quote](#)

BenchChem

Our mission is to be the trusted global source of essential and advanced chemicals, empowering scientists and researchers to drive progress in science and industry.

Contact

Address: 3281 E Guasti Rd
Ontario, CA 91761, United States
Phone: (601) 213-4426
Email: info@benchchem.com

[Contact our Ph.D. Support Team for a compatibility check](#)