

Introduction: The Critical Role of Frontier Molecular Orbitals in Hole Transport Materials

Author: BenchChem Technical Support Team. **Date:** April 2026

Compound of Interest

Compound Name: 2,3,4,5-Tetrafluoro-N-phenylaniline

CAS No.: 58627-14-8

Cat. No.: B14623098

[Get Quote](#)

In the realm of organic electronics, particularly in devices such as perovskite solar cells (PSCs) and organic light-emitting diodes (OLEDs), the performance and stability are intrinsically linked to the properties of the charge-transporting layers. Hole transport materials (HTMs) are a crucial component, facilitating the efficient movement of positive charge carriers (holes) and blocking electrons.^{[1][2]} The efficacy of an HTM is largely governed by the energy levels of its frontier molecular orbitals: the Highest Occupied Molecular Orbital (HOMO) and the Lowest Unoccupied Molecular Orbital (LUMO).^{[3][4]}

The HOMO level dictates the material's ability to donate an electron (its oxidation potential) and must be well-aligned with the valence band of the active layer (e.g., the perovskite) to ensure efficient hole extraction.^[1] The LUMO level, representing the ability to accept an electron, is crucial for blocking electrons from reaching the anode, thereby preventing recombination losses. The difference between the HOMO and LUMO levels, the HOMO-LUMO gap, is a key determinant of the material's electronic and optical properties.^{[3][5]}

The Impact of Fluorination: A Strategy for Tuning HOMO-LUMO Energy Levels

Fluorination, the strategic incorporation of fluorine atoms into the molecular structure of HTMs, has emerged as a powerful tool for tuning their electronic properties.[1][6] Due to the high electronegativity of fluorine, its inclusion as a substituent has a profound electron-withdrawing effect.[6][7] This systematically lowers the energy levels of both the HOMO and LUMO.[1][6][7] This energy level depression is a key strategy for enhancing the performance and stability of organic electronic devices.

The primary advantages of fluorinating amine-based HTMs include:

- **Improved Energy Level Alignment:** By lowering the HOMO level, fluorination can create a more favorable energy cascade for hole injection from the perovskite layer to the HTM, which can lead to an increased open-circuit voltage (Voc) in solar cells.[7]
- **Enhanced Stability:** The introduction of fluorine can increase the ionization potential of the material, making it more resistant to degradation under operational stress.[1][7] Fluorinated compounds also tend to be more hydrophobic, offering better protection against moisture-induced degradation of the perovskite layer.[8]
- **Modified Morphology:** Fluorination can influence the solid-state packing of the HTM molecules, which in turn affects their charge-transport properties.[1][6]

However, excessive fluorination can sometimes lead to an unfavorable offset in the valence band, though studies have shown that for a range of substitutions, hole transfer remains favorable.[7]

Quantitative Analysis: HOMO-LUMO Levels of Fluorinated vs. Non-Fluorinated Amine HTMs

The following table summarizes the HOMO and LUMO energy levels of some common amine-based HTMs and their fluorinated analogues, illustrating the impact of fluorination.

Hole Transport Material	HOMO (eV)	LUMO (eV)	HOMO-LUMO Gap (eV)	Reference
Spiro-OMeTAD	-5.0	-2.05	2.95	[3]
Spiro-mF (Fluorinated)	Lowered	Lowered	Tuned	[8]
Spiro-oF (Fluorinated)	Lowered	Lowered	Tuned	[8]
YC-H (CPDT-based)	-	-	-	[9]
YC-oF (Fluorinated)	Lowered	Lowered	-	[9]
YC-mF (Fluorinated)	Lowered	Lowered	-	[9]

Note: Specific energy level values for some fluorinated compounds are often presented in research articles in comparison to their non-fluorinated counterparts, highlighting the trend of energy level depression.

Experimental Determination of HOMO-LUMO Energy Levels

Accurate determination of HOMO and LUMO energy levels is paramount for designing efficient devices. Several experimental techniques are employed for this purpose.

Cyclic Voltammetry (CV)

Cyclic voltammetry is a widely used electrochemical method to determine the oxidation and reduction potentials of a molecule, which can then be used to estimate the HOMO and LUMO energy levels.[3][4][10]

Principle: The technique involves applying a linearly varying potential to a working electrode immersed in a solution containing the analyte and a supporting electrolyte.[10] The resulting current is measured as a function of the applied potential, producing a cyclic voltammogram.

The potential at which the molecule is oxidized corresponds to the removal of an electron from the HOMO, while the reduction potential corresponds to the addition of an electron to the LUMO.[4]

Experimental Protocol: Determination of HOMO/LUMO Levels using Cyclic Voltammetry

1. Materials and Equipment:

- Electrochemical workstation (potentiostat/galvanostat)
- Three-electrode cell:
- Working electrode (e.g., glassy carbon or platinum)
- Reference electrode (e.g., Ag/AgCl or saturated calomel electrode - SCE)
- Counter electrode (e.g., platinum wire)
- Analyte (fluorinated amine HTM)
- Anhydrous, deoxygenated solvent (e.g., dichloromethane, acetonitrile)
- Supporting electrolyte (e.g., tetrabutylammonium hexafluorophosphate - TBAPF₆)
- Inert gas (e.g., argon or nitrogen) for deaeration

2. Procedure:

- Solution Preparation: Dissolve the HTM and the supporting electrolyte in the solvent to prepare a solution of known concentration (typically in the millimolar range).
- Deaeration: Purge the solution with the inert gas for at least 15-20 minutes to remove dissolved oxygen, which can interfere with the measurements.[10]
- Electrochemical Cell Assembly: Assemble the three-electrode cell with the prepared solution, ensuring the electrodes are properly immersed.
- Cyclic Voltammetry Measurement:
- Set the potential range to scan through the expected oxidation and reduction events.
- Set the scan rate (e.g., 50-100 mV/s).
- Run the cyclic voltammetry experiment, recording the current-potential curve.
- Data Analysis:
- From the cyclic voltammogram, determine the onset oxidation potential (E_{ox}) and onset reduction potential (E_{red}).
- Calculate the HOMO and LUMO energy levels using the following empirical formulas[4]:
- E_{HOMO} (eV) = - (E_{ox} vs. Fc/Fc⁺ + 4.8)
- E_{LUMO} (eV) = - (E_{red} vs. Fc/Fc⁺ + 4.8)
- Note: It is best practice to reference the potentials to the ferrocene/ferrocenium (Fc/Fc⁺) redox couple as an internal standard.

3. Self-Validation:

- Run multiple cycles to ensure the reversibility of the redox processes.
- Vary the scan rate to confirm that the peak currents are proportional to the square root of the scan rate for a diffusion-controlled process.
- Measure the Fc/Fc⁺ couple under the same conditions to accurately reference the potentials.

Diagram of a Cyclic Voltammetry Experimental Setup

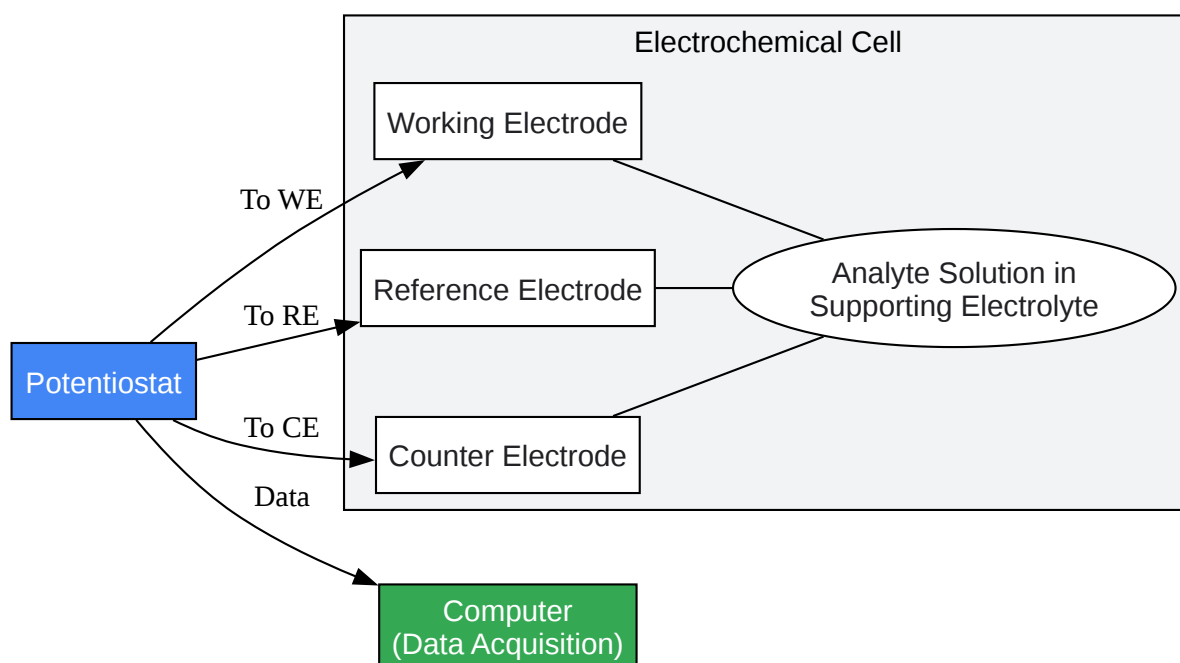

[Click to download full resolution via product page](#)

Caption: A schematic of a typical three-electrode setup for cyclic voltammetry measurements.

Ultraviolet Photoelectron Spectroscopy (UPS)

UPS is a surface-sensitive technique that directly measures the energy of occupied electronic states, providing a precise value for the HOMO level (ionization potential).[3][11]

Principle: The sample is irradiated with ultraviolet photons of a known energy (e.g., from a He I source at 21.22 eV).[12] The kinetic energy of the photoemitted electrons is measured. The binding energy of the electrons can then be determined by subtracting the kinetic energy from the photon energy. The onset of the highest kinetic energy peak in the UPS spectrum corresponds to the HOMO level relative to the Fermi level.[13][14]

Diagram of the UPS Measurement Principle

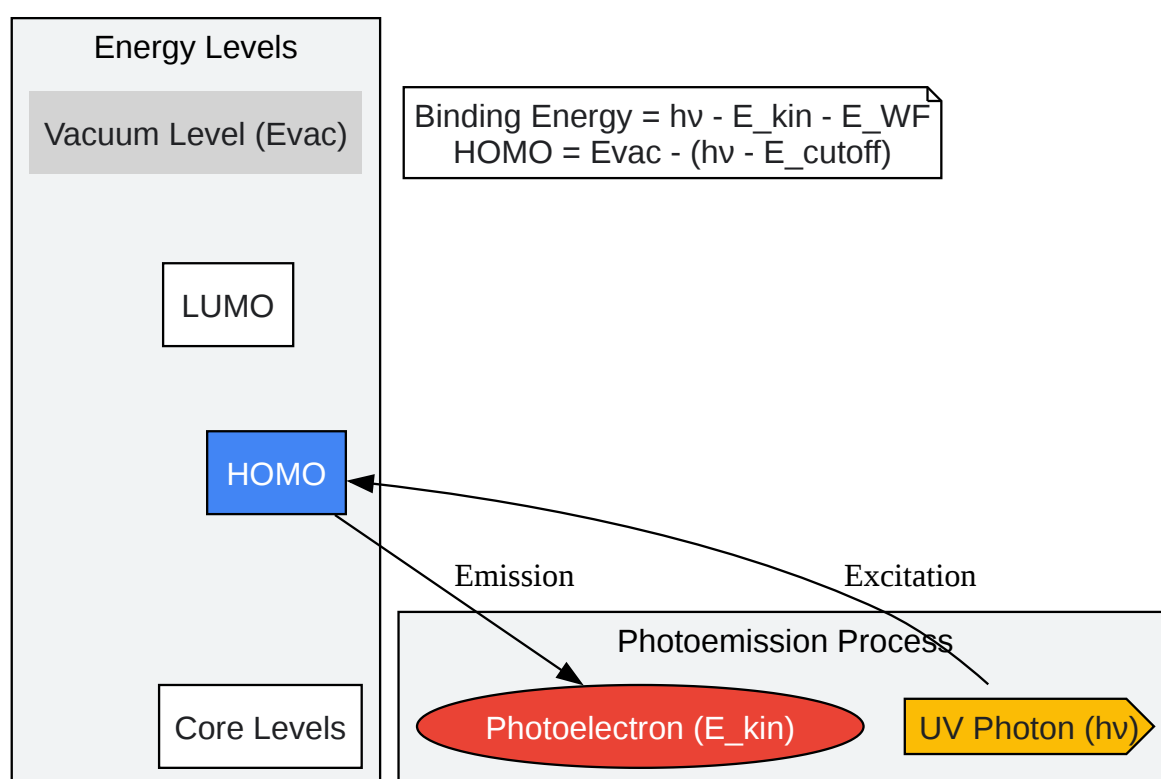

[Click to download full resolution via product page](#)

Caption: Energy level diagram illustrating the principle of Ultraviolet Photoelectron Spectroscopy.

Computational Modeling of HOMO-LUMO Levels

Computational chemistry, particularly Density Functional Theory (DFT), is a powerful tool for predicting and understanding the electronic structure of molecules.^{[3][15]} DFT calculations can provide valuable insights into how chemical modifications, such as fluorination, will affect the HOMO and LUMO energy levels before a molecule is synthesized.^{[16][17]}

Methodology:

- **Geometry Optimization:** The first step is to find the lowest energy conformation of the molecule.
- **Electronic Structure Calculation:** A suitable functional (e.g., B3LYP) and basis set (e.g., 6-31G**) are chosen to calculate the molecular orbital energies.^[15]

Computational methods allow for the systematic screening of a large number of potential HTM candidates, accelerating the materials discovery process.^[18]

Workflow for Computational Prediction of HOMO-LUMO Levels

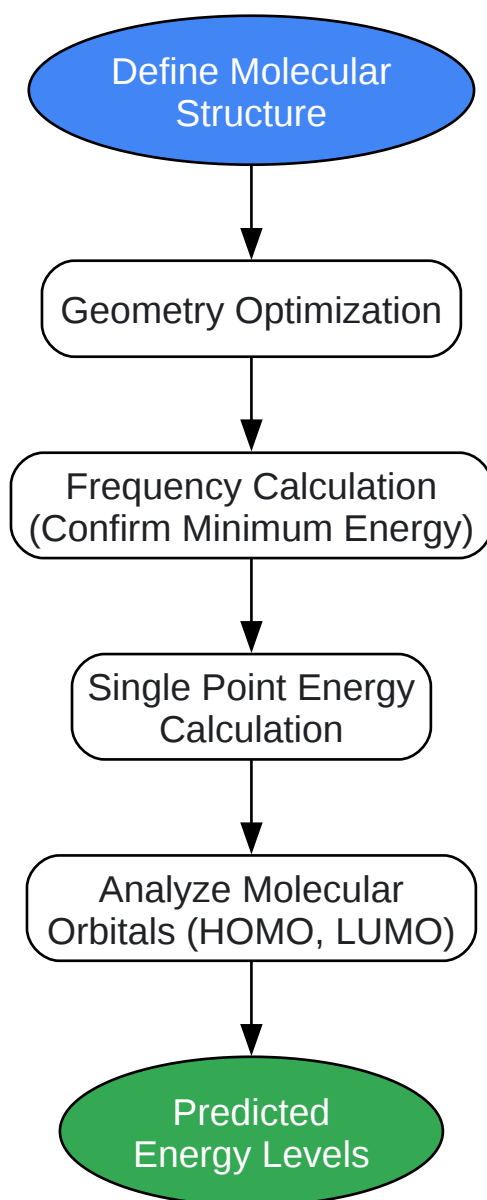

[Click to download full resolution via product page](#)

Caption: A typical workflow for predicting HOMO-LUMO energy levels using DFT calculations.

Conclusion: Design Principles for Advanced Fluorinated Amine HTMs

The strategic fluorination of amine-based hole transport materials provides a robust method for tuning their HOMO and LUMO energy levels, leading to significant improvements in the efficiency and stability of organic electronic devices. A comprehensive understanding of the interplay between molecular structure and electronic properties, gained through a combination

of experimental characterization and computational modeling, is essential for the rational design of next-generation HTMs. By carefully controlling the degree and position of fluorination, researchers can fine-tune the frontier molecular orbital energies to achieve optimal device performance.

References

- Impact of fluorination on the energy level alignment of an F n ZnPc/MAPbI₃ interface. (2022). RSC Advances.
- CHARACTERIZATION OF ORGANIC SEMICONDUCTORS USING CYCLIC VOLTAMMETRY. (n.d.). Sathyabama Institute of Science and Technology.
- Understanding HOMO and LUMO in Chemistry. (n.d.). Ossila.
- Hole-Transporting Materials for Printable Perovskite Solar Cells. (2017). MDPI.
- HOMO and LUMO Analysis through Cyclic Voltammetry. (2024). Prezi.
- Fluorination effects on bithiophene bridged hole transporting materials for perovskite solar cells. (2024). Taylor & Francis Group - Figshare.
- Which is suitable technique for HOMO and LUMO measurement of organic semiconductors? (2015).
- Method for determining LUMO value and HOMO value of semiconductor nano-crystals through utilizing cyclic voltammetry. (n.d.).
- Design rules for high mobility xanthene-based hole transport m
- Fluorination on cyclopentadithiophene-based hole-transport materials for high-performance perovskite solar cells. (n.d.).
- Fluorination of Terminal Groups Promoting Electron Transfer in Small Molecular Acceptors of Bulk Heterojunction Films. (2022). PMC.
- A review on the classification of organic/inorganic/carbonaceous hole transporting materials for perovskite solar cell application. (2018). Arabian Journal of Chemistry.
- Fluorinated polymer additives in Spiro-OMeTAD to improve the efficiency and stability of perovskite solar cells. (2025).
- Effect of Ortho -Fluorine Substituted Hole Transport Materials for Perovskite Solar Cells: Influence of Rigid vs. Flexible Linkers. (2025).
- Chemical structures of Spiro-OMeTAD and its fluorinated analogs... (n.d.).
- Predicting HOMO and LUMO Energy Levels Using a Graph Convolutional Network-Based Deep Learning Model. (n.d.). UW-Eau Claire.
- Energy level alignment of electrically doped hole transport layers with transparent and conductive indium tin oxide and polymer anodes. (2007). SciSpace.
- Molecular orbital energy spacing, including HOMO–LUMO gap (HLG), for aniline and fluoroanilines. (n.d.).

- Effect of Molecular Structure on the B3LYP-Computed HOMO–LUMO Gap: A Structure–Property Relationship Using Atomic Sign
- A Review of Inorganic Hole Transport Materials for Perovskite Solar Cells. (n.d.). Scilit.
- The Evolution of Classical Spiro-OMeTAD: Synthesis of Arylamine Endcapped Indenone Spirofluorene. (2022). Frontiers.
- Sustainable, Efficient, and Scalable Preparation of Pure and Performing Spiro-OMeTAD for Perovskite Solar Cells. (2022).
- Ultraviolet Photoelectron Spectroscopy (UPS). (n.d.).
- Fluorinated polymer additives in Spiro-OMeTAD to improve the efficiency and stability of perovskite solar cells. (2024).
- Reorganization Energies in the Transports of Holes and Electrons in Organic Amines in Organic Electroluminescence Studied by Density Functional Theory. (2003). The Journal of Physical Chemistry A.
- High throughput tight binding calculation of electronic HOMO–LUMO gaps and its prediction for natural compounds. (n.d.). Digital Discovery (RSC Publishing).
- The ultraviolet photoelectron spectroscopy (UPS) spectra of the (a)... (n.d.).
- A computational quantum chemical study of Fluorinated Allopurinol. (2022).
- Maximising OLED performance: Unleashing the power of stacking transport, injection and blocking layers along with different emissive materials. (n.d.). Indian Academy of Sciences.
- Molecular Structure, FT-IR Spectra, MEP and HOMO-LUMO Investigation of 2-(4-Fluorophenyl)-5-phenyl-1, 3,4-oxadiazole Using DFT Theory Calculations. (2021). Advanced Journal of Chemistry, Section A.
- The Optimization of Hole Injection Layer in Organic Light-Emitting Diodes. (2024). PMC.
- Augmenting Molecular Graphs with Geometries via Machine Learning Inter
- Computational Insights into the Electronic Landscape of Fluoroazulenes: A Technical Overview. (n.d.). Benchchem.
- Computational Chemistry Research Unit. (n.d.). RIKEN.
- Enhancing OLED Performance by Optimizing the Hole Transport Layer with a Self-Assembled Monolayer. (2025). MDPI.
- Ultraviolet Spectroscopy. (2019). Chemistry LibreTexts.
- How to determine HOMO level
- Supporting inform

Need Custom Synthesis?

BenchChem offers custom synthesis for rare earth carbides and specific isotopic labeling.

Email: info@benchchem.com or [Request Quote Online](#).

Sources

- [1. mdpi.com \[mdpi.com\]](#)
- [2. A review on the classification of organic/inorganic/carbonaceous hole transporting materials for perovskite solar cell application - Arabian Journal of Chemistry \[arabjchem.org\]](#)
- [3. ossila.com \[ossila.com\]](#)
- [4. prezi.com \[prezi.com\]](#)
- [5. pubs.acs.org \[pubs.acs.org\]](#)
- [6. Fluorination of Terminal Groups Promoting Electron Transfer in Small Molecular Acceptors of Bulk Heterojunction Films - PMC \[pmc.ncbi.nlm.nih.gov\]](#)
- [7. Impact of fluorination on the energy level alignment of an F n ZnPc/MAPbI 3 interface - Nanoscale Advances \(RSC Publishing\) DOI:10.1039/D2NA00582D \[pubs.rsc.org\]](#)
- [8. researchgate.net \[researchgate.net\]](#)
- [9. Fluorination on cyclopentadithiophene-based hole-transport materials for high-performance perovskite solar cells - Chemical Communications \(RSC Publishing\) \[pubs.rsc.org\]](#)
- [10. cdm16771.contentdm.oclc.org \[cdm16771.contentdm.oclc.org\]](#)
- [11. researchgate.net \[researchgate.net\]](#)
- [12. public.archive.wsu.edu \[public.archive.wsu.edu\]](#)
- [13. researchgate.net \[researchgate.net\]](#)
- [14. researchgate.net \[researchgate.net\]](#)
- [15. pdf.benchchem.com \[pdf.benchchem.com\]](#)
- [16. tandf.figshare.com \[tandf.figshare.com\]](#)
- [17. researchgate.net \[researchgate.net\]](#)
- [18. Design rules for high mobility xanthene-based hole transport materials - Chemical Science \(RSC Publishing\) DOI:10.1039/C9SC01491H \[pubs.rsc.org\]](#)
- [To cite this document: BenchChem. \[Introduction: The Critical Role of Frontier Molecular Orbitals in Hole Transport Materials\]. BenchChem, \[2026\]. \[Online PDF\]. Available at: \[https://www.benchchem.com/product/b14623098/docs#introduction-the-critical-role-of-frontier-molecular-orbitals-in-hole-transport-materials\]](#)

Disclaimer & Data Validity:

The information provided in this document is for Research Use Only (RUO) and is strictly not intended for diagnostic or therapeutic procedures. While BenchChem strives to provide accurate protocols, we make no warranties, express or implied, regarding the fitness of this product for every specific experimental setup.

Technical Support: The protocols provided are for reference purposes. Unsure if this reagent suits your experiment?

Need Industrial/Bulk Grade? [Request Custom Synthesis Quote](#)

BenchChem

Our mission is to be the trusted global source of essential and advanced chemicals, empowering scientists and researchers to drive progress in science and industry.

Contact

Address: 3281 E Guasti Rd
Ontario, CA 91761, United States
Phone: (601) 213-4426
Email: info@benchchem.com

[Contact our Ph.D. Support Team for a compatibility check](#)