

Technical Support Center: Synthesis of Boc-4-methyl-DL-tryptophan

Author: BenchChem Technical Support Team. **Date:** May 2026

Compound of Interest

Compound Name: *Boc-4-methyl-DL-tryptophan*

CAS No.: 1219232-56-0

Cat. No.: B1462776

[Get Quote](#)

Welcome to the technical support center for the synthesis of N α -(tert-Butoxycarbonyl)-4-methyl-DL-tryptophan. This guide is designed for researchers, scientists, and drug development professionals to provide in-depth, field-proven insights into optimizing reaction yields and troubleshooting common experimental challenges.

Frequently Asked Questions (FAQs)

Q1: What is the fundamental reaction for synthesizing Boc-4-methyl-DL-tryptophan?

The synthesis involves the protection of the α -amino group of 4-methyl-DL-tryptophan using di-tert-butyl dicarbonate (Boc anhydride, Boc₂O). The reaction is a nucleophilic acylation where the deprotonated amino group of the tryptophan derivative attacks one of the carbonyl carbons of the Boc anhydride. This forms a stable tert-butyl carbamate, effectively "protecting" the amine from participating in subsequent reactions, such as peptide coupling.^{[1][2][3]} The byproducts are carbon dioxide and tert-butanol, which are easily removed.^[4]

Q2: Why is pH control critical during the reaction?

Proper pH management is arguably the most critical factor for achieving a high yield. The α -amino group of the starting material must be in its nucleophilic, unprotonated state ($-\text{NH}_2$) to react with the Boc anhydride.

- If the pH is too low (acidic): The amino group will be protonated ($-\text{NH}_3^+$). This positively charged ammonium group is not nucleophilic and will not react with the Boc anhydride. A common procedure involves adjusting the pH to around 2.4 during workup to protonate the carboxylic acid for extraction, but the reaction itself must be basic.[5]
- If the pH is too high (strongly basic): This can lead to two primary issues:
 - Hydrolysis of Boc Anhydride: Boc_2O is susceptible to hydrolysis under strongly basic conditions, consuming the reagent before it can react with the amino acid.
 - Racemization or other side reactions: While less common for simple Boc protection, extreme pH values can compromise the integrity of the starting material.

A moderately basic pH (typically 8.5-10) provides the optimal balance, ensuring the amino group is sufficiently deprotonated for reaction while minimizing reagent decomposition.[5]

Q3: What are the best solvent and base combinations for this synthesis?

The starting material, 4-methyl-DL-tryptophan, is a zwitterionic amino acid, making it soluble in water but poorly soluble in many organic solvents.[6] Conversely, Boc anhydride is nonpolar and soluble in organic solvents. Therefore, a biphasic or homogeneous aqueous-organic solvent system is required.

Commonly used systems include:

- Dioxane/Water: A popular choice that provides good solubility for both reactants.[5]
- Tetrahydrofuran (THF)/Water: Another effective mixture.
- Methanol (MeOH): In some cases, reactions can be run in protic solvents like methanol, which can help activate the Boc anhydride via hydrogen bonding.[1]

The base is chosen to maintain the target pH. Common choices include:

- Sodium Hydroxide (NaOH) or Sodium Bicarbonate (NaHCO₃): Inorganic bases used in aqueous systems. NaOH is stronger and requires careful monitoring of the pH.[\[1\]](#)[\[5\]](#)
- Triethylamine (TEA) or N,N-Diisopropylethylamine (DIPEA): Organic bases often used in primarily organic solvent systems or as a pH modifier.[\[1\]](#)

General Synthesis & Workflow

Reaction Mechanism

The diagram below illustrates the nucleophilic attack of the deprotonated amino group on the Boc anhydride, leading to the formation of the protected amino acid.

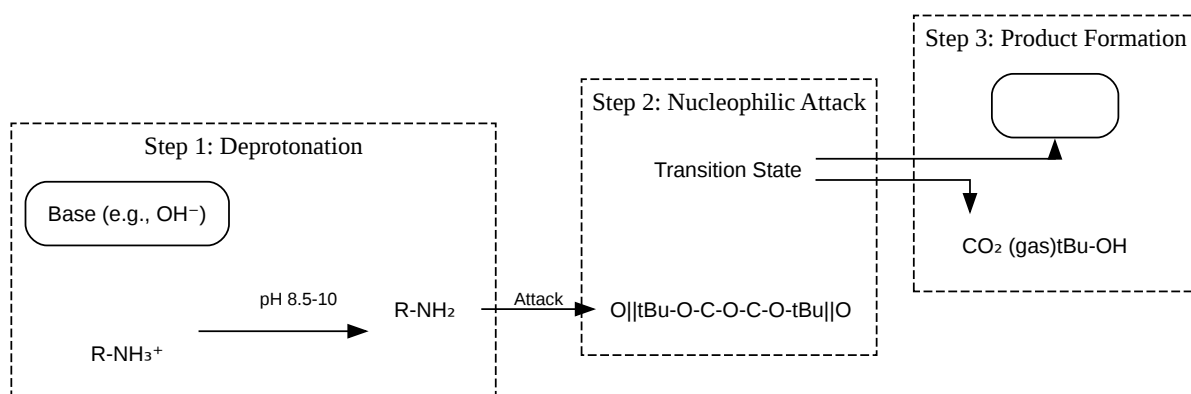

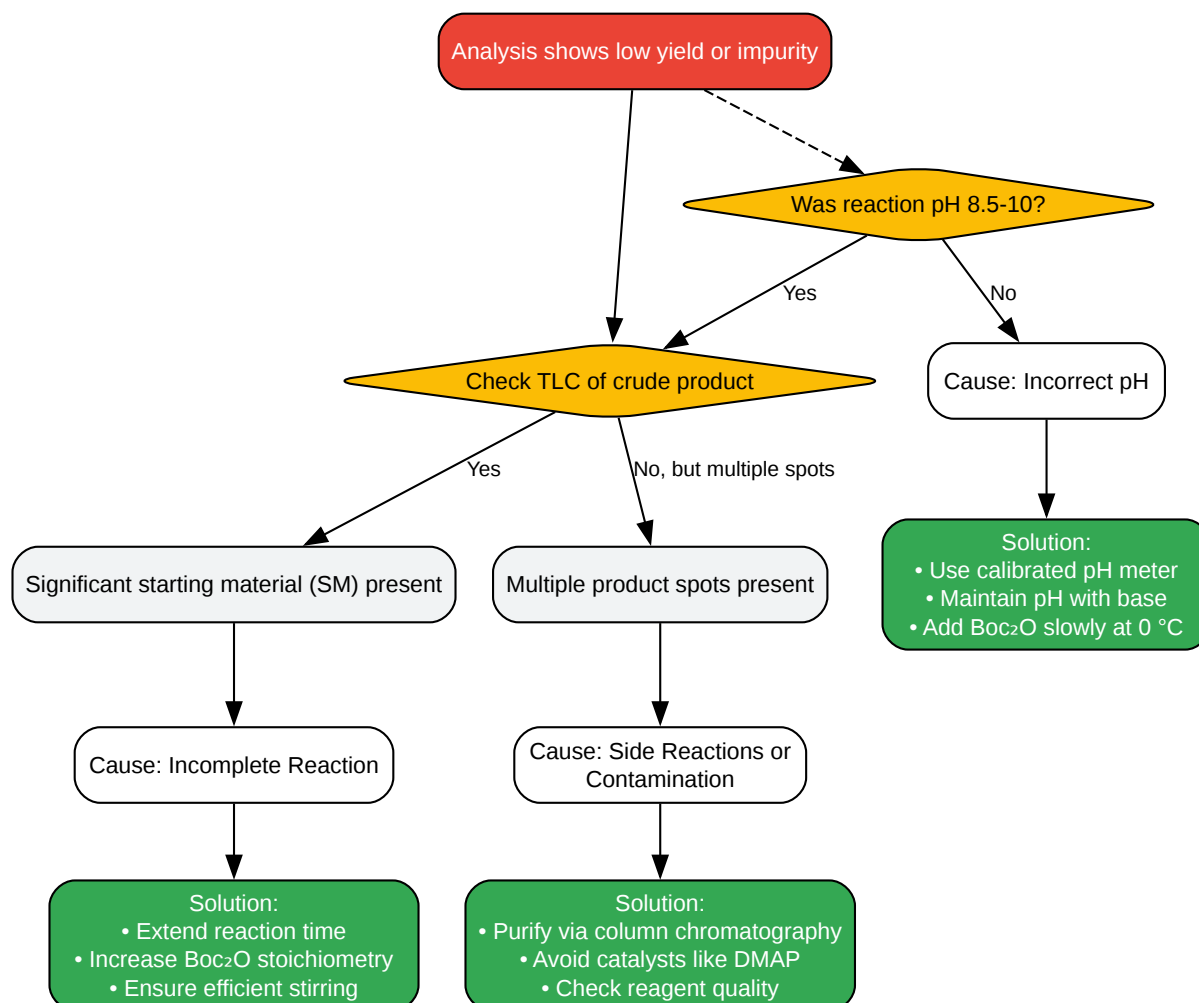

[Click to download full resolution via product page](#)

Need Custom Synthesis?

BenchChem offers custom synthesis for rare earth carbides and specific isotopic labeling.

Email: info@benchchem.com or [Request Quote Online](#).

Sources

- [1. en.highfine.com \[en.highfine.com\]](https://en.highfine.com)
- [2. aapep.bocsci.com \[aapep.bocsci.com\]](https://aapep.bocsci.com)
- [3. Understanding Boc Anhydride: A Key Player in Organic Chemistry - Oreate AI Blog \[oreateai.com\]](#)
- [4. nbinno.com \[nbinno.com\]](https://nbinno.com)
- [5. Synthesis and Biological Evaluation of Novel 1-Alkyl-tryptophan Analogs as Potential Antitumor Agents - PMC \[pmc.ncbi.nlm.nih.gov\]](#)
- [6. sigmaaldrich.com \[sigmaaldrich.com\]](https://sigmaaldrich.com)
- To cite this document: BenchChem. [Technical Support Center: Synthesis of Boc-4-methyl-DL-tryptophan]. BenchChem, [2026]. [Online PDF]. Available at: [\[https://www.benchchem.com/product/b1462776/docs#technical-support-center-synthesis-of-boc-4-methyl-dl-tryptophan\]](https://www.benchchem.com/product/b1462776/docs#technical-support-center-synthesis-of-boc-4-methyl-dl-tryptophan)

Disclaimer & Data Validity:

The information provided in this document is for Research Use Only (RUO) and is strictly not intended for diagnostic or therapeutic procedures. While BenchChem strives to provide accurate protocols, we make no warranties, express or implied, regarding the fitness of this product for every specific experimental setup.

Technical Support: The protocols provided are for reference purposes. Unsure if this reagent suits your experiment?

Need Industrial/Bulk Grade? [Request Custom Synthesis Quote](#)

BenchChem

Our mission is to be the trusted global source of essential and advanced chemicals, empowering scientists and researchers to drive progress in science and industry.

Contact

Address: 3281 E Guasti Rd
Ontario, CA 91761, United States
Phone: (601) 213-4426
Email: info@benchchem.com

Contact our Ph.D. Support Team for a compatibility check