

photophysical properties of N-Ethyl-1-naphthylamine Hydrobromide

Author: BenchChem Technical Support Team. **Date:** January 2026

Compound of Interest

Compound Name: *N-Ethyl-1-naphthylamine Hydrobromide*
Cat. No.: *B1461567*

[Get Quote](#)

An In-depth Technical Guide to the Photophysical Properties of **N-Ethyl-1-naphthylamine Hydrobromide**

Introduction: Unveiling the Potential of a Classic Fluorophore

N-Ethyl-1-naphthylamine (NEA) belongs to the well-established family of aminonaphthalene fluorescent probes. These molecules are renowned for their sensitivity to the local molecular environment, making them invaluable tools in chemical and biological research. The hydrobromide salt of NEA (NEA-HBr) is often utilized to improve its solubility in aqueous media, expanding its applicability in biological systems.

This technical guide serves as a comprehensive resource for researchers, scientists, and drug development professionals seeking to understand and exploit the photophysical properties of NEA. While direct, consolidated photophysical data for NEA is sparse in the literature, this document will leverage the well-documented behavior of its parent compound, 1-naphthylamine, and related derivatives like N-phenyl-1-naphthylamine to establish a robust theoretical and practical framework.

The core focus of this guide is not merely to present data, but to explain the causality behind the photophysical phenomena and to provide detailed, field-proven protocols for their empirical validation. We will explore the fundamental principles governing its fluorescence, the

experimental workflows required for its characterization, and its potential applications as a sensitive probe for microenvironments.

Part 1: Foundational Photophysical Principles

The interaction of light with a fluorophore like N-Ethyl-1-naphthylamine is elegantly described by the Jablonski diagram. This model illustrates the electronic transitions that occur between different energy states, governing the processes of absorption and fluorescence.

The Jablonski Diagram: A Conceptual Overview

A molecule typically resides in its lowest vibrational level of the electronic ground state (S_0). Upon absorbing a photon of appropriate energy, it is rapidly promoted to a higher vibrational level of an excited singlet state (S_1). This is followed by a very fast non-radiative process called vibrational relaxation, where the molecule loses excess vibrational energy and relaxes to the lowest vibrational level of the S_1 state. From here, it can return to the ground state via several pathways, the most important of which for our purposes is fluorescence—the emission of a photon.

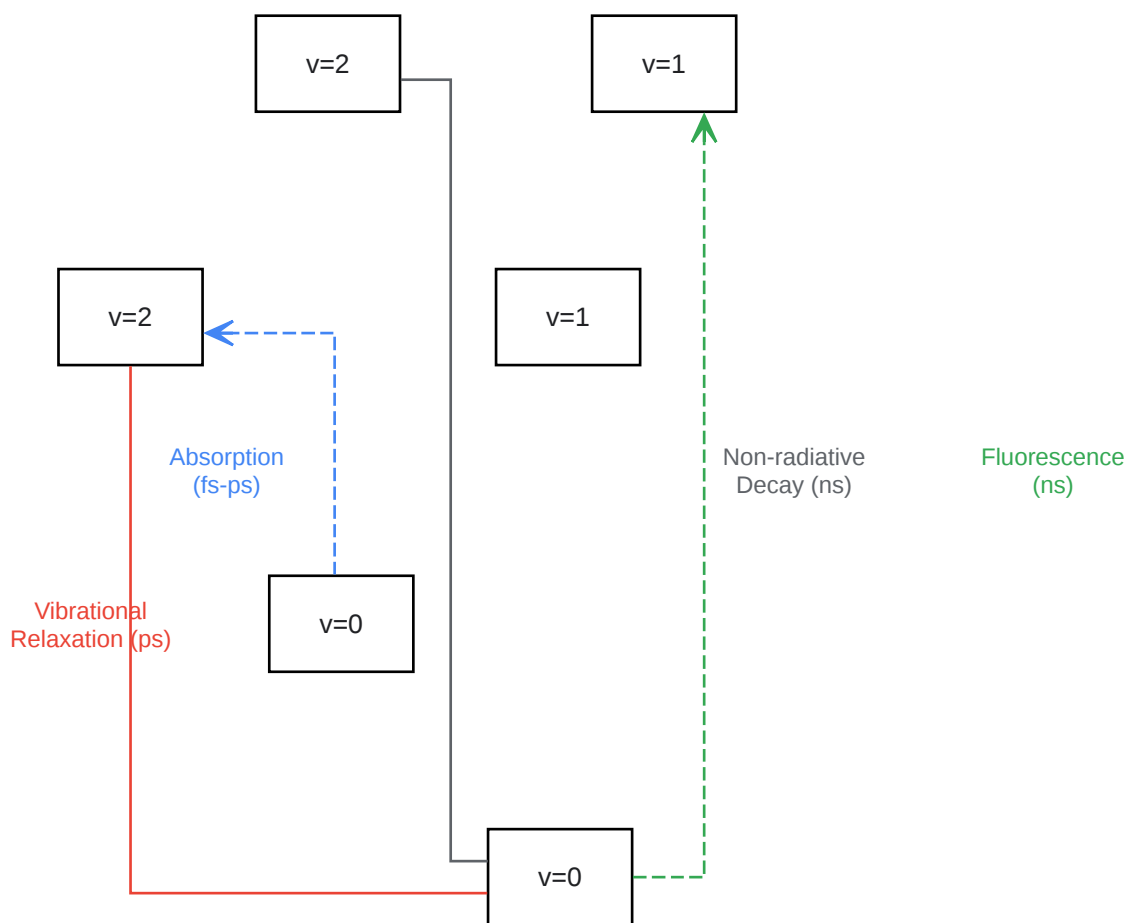

[Click to download full resolution via product page](#)

Caption: Simplified Jablonski diagram for a fluorophore like NEA.

Key Photophysical Parameters

- Absorption and Molar Absorptivity (ϵ): Absorption refers to the $S_0 \rightarrow S_1$ transition. The efficiency of this process is quantified by the molar absorptivity (or extinction coefficient), ϵ , a constant defined by the Beer-Lambert law. It is a measure of how strongly the molecule absorbs light at a specific wavelength.
- Stokes Shift: Fluorescence emission almost always occurs at a lower energy (longer wavelength) than absorption. This energy difference between the absorption maximum (λ_{abs}) and the emission maximum (λ_{em}) is known as the Stokes Shift. A larger Stokes shift is often desirable as it simplifies the optical detection of fluorescence by separating the emission signal from scattered excitation light.

- **Fluorescence Quantum Yield (Φ_F):** This is the ultimate measure of a fluorophore's emission efficiency. It is defined as the ratio of the number of photons emitted to the number of photons absorbed.[1] A quantum yield of 1.0 represents perfect efficiency, where every absorbed photon results in an emitted photon. In practice, values are less than 1 due to competing non-radiative decay pathways.
- **Fluorescence Lifetime (τ_F):** This is the average time a molecule spends in the excited state (S_1) before returning to the ground state.[2] Lifetimes are typically on the nanosecond timescale.[3] This parameter is highly sensitive to the fluorophore's environment and can be affected by factors such as solvent polarity, viscosity, and the presence of quenching molecules.

Part 2: Experimental Characterization Protocols

Accurate determination of the photophysical parameters is critical for any application. The following sections detail the standard, validated protocols for these measurements.

Protocol 1: Determination of Relative Fluorescence Quantum Yield (Φ_F)

The most common and reliable method for determining Φ_F is the comparative method, which measures the fluorescence of the sample relative to a well-characterized standard with a known quantum yield.[4]

Principle: For dilute solutions with identical absorbance at the same excitation wavelength, it is assumed that both the sample and the standard absorb the same number of photons.[5] Therefore, the ratio of their integrated fluorescence intensities is directly proportional to the ratio of their quantum yields.[5]

Methodology:

- **Selection of a Standard:** Choose a standard that absorbs and emits in a similar spectral region to the sample. For NEA (expected λ_{abs} ~320 nm, λ_{em} ~400-450 nm), Quinine Sulfate in 0.1 M H_2SO_4 ($\Phi_F \approx 0.55$) is a suitable choice.
- **Solution Preparation:**

- Prepare a stock solution of NEA-HBr and the standard in the desired spectroscopic-grade solvent.
- Create a series of 5-6 dilutions for both the sample and the standard. The absorbance of these solutions at the chosen excitation wavelength should be kept below 0.1 AU in a 10 mm cuvette to avoid inner filter effects.[4]
- Absorbance Measurement:
 - Using a UV-Vis spectrophotometer, record the absorbance spectrum for each dilution.
 - Note the absorbance value at the chosen excitation wavelength (e.g., 320 nm).
- Fluorescence Measurement:
 - Using a spectrofluorometer, record the corrected emission spectrum for each dilution, using the same excitation wavelength and instrument settings (e.g., slit widths) for all measurements.
 - Calculate the integrated fluorescence intensity (the area under the emission curve) for each spectrum.[1]
- Data Analysis and Calculation:
 - For both the sample and the standard, plot the integrated fluorescence intensity (y-axis) versus the absorbance (x-axis).
 - Perform a linear regression for each data set. The slope of the line is the gradient (Grad). [5]
 - Calculate the quantum yield of the sample (Φ_X) using the following equation:[4] $\Phi_X = \Phi_{ST} * (\text{Grad}_X / \text{Grad}_{ST}) * (\eta_X^2 / \eta_{ST}^2)$ Where:
 - Φ_{ST} is the quantum yield of the standard.
 - Grad_X and Grad_{ST} are the gradients for the sample and standard, respectively.
 - η_X and η_{ST} are the refractive indices of the sample and standard solvents, respectively.

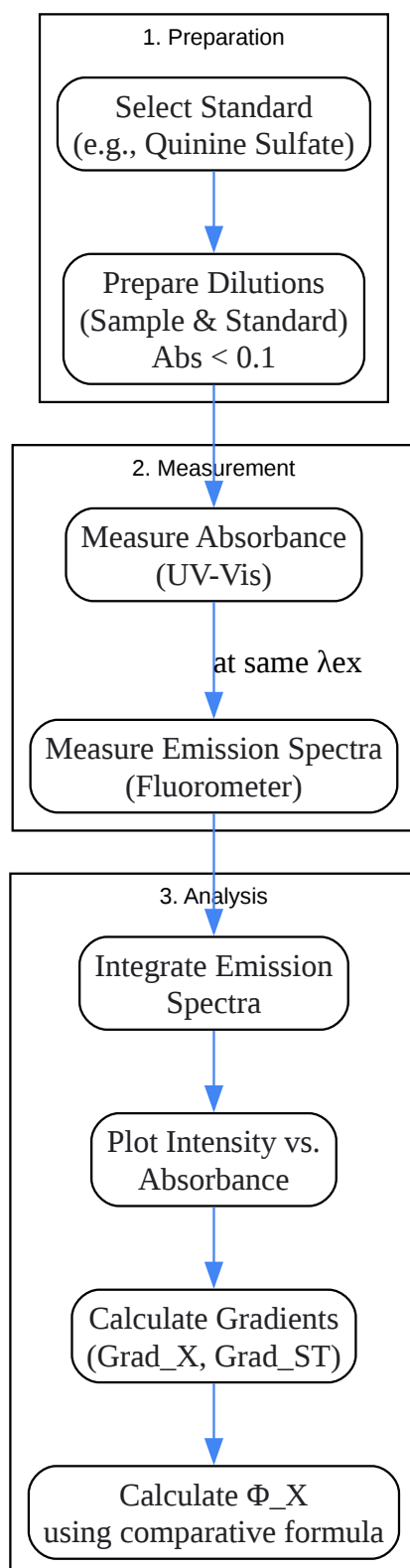

[Click to download full resolution via product page](#)

Caption: Workflow for relative fluorescence quantum yield measurement.

Protocol 2: Measurement of Fluorescence Lifetime (τ_F) using TCSPC

Time-Correlated Single Photon Counting (TCSPC) is the gold-standard technique for measuring fluorescence lifetimes in the picosecond to microsecond range.[2][6]

Principle: TCSPC reconstructs the fluorescence decay profile by measuring the arrival time of individual photons relative to a repeating, pulsed excitation source (e.g., a laser or LED).[7] The instrument repeatedly excites the sample and measures the time delay for the first detected photon after each pulse. By collecting millions of these events, a histogram of photon arrival times is built, which mirrors the fluorescence decay curve.[8]

Methodology:

- Instrument Setup: A TCSPC system consists of a high-repetition-rate pulsed light source, a sample holder, a sensitive single-photon detector (like a PMT), and timing electronics (a Time-to-Digital Converter, TDC).[2]
- Instrument Response Function (IRF):
 - First, measure the system's own temporal response by recording the "decay" of a scattering solution (e.g., a dilute colloidal silica suspension) at the excitation wavelength. This profile is the IRF, or "prompt," and represents the fastest decay the system can measure.[3]
- Sample Measurement:
 - Place the NEA-HBr solution in the sample holder. The concentration should be adjusted to ensure the photon detection rate is low (typically <5% of the laser repetition rate) to avoid "pulse pile-up" artifacts, where more than one photon arrives per excitation cycle.[3]
 - Collect data until a sufficient number of photons (e.g., 10,000 in the peak channel) are acquired to form a smooth decay curve.
- Data Analysis:
 - The measured decay curve is a convolution of the true fluorescence decay and the IRF.

- Use specialized software to perform an iterative reconvolution fit. The software convolves the IRF with a theoretical decay model (e.g., a single or multi-exponential function) and adjusts the lifetime parameters (τ) until the calculated curve best fits the experimental data.
- The quality of the fit is assessed by examining the weighted residuals and the chi-squared (χ^2) value.

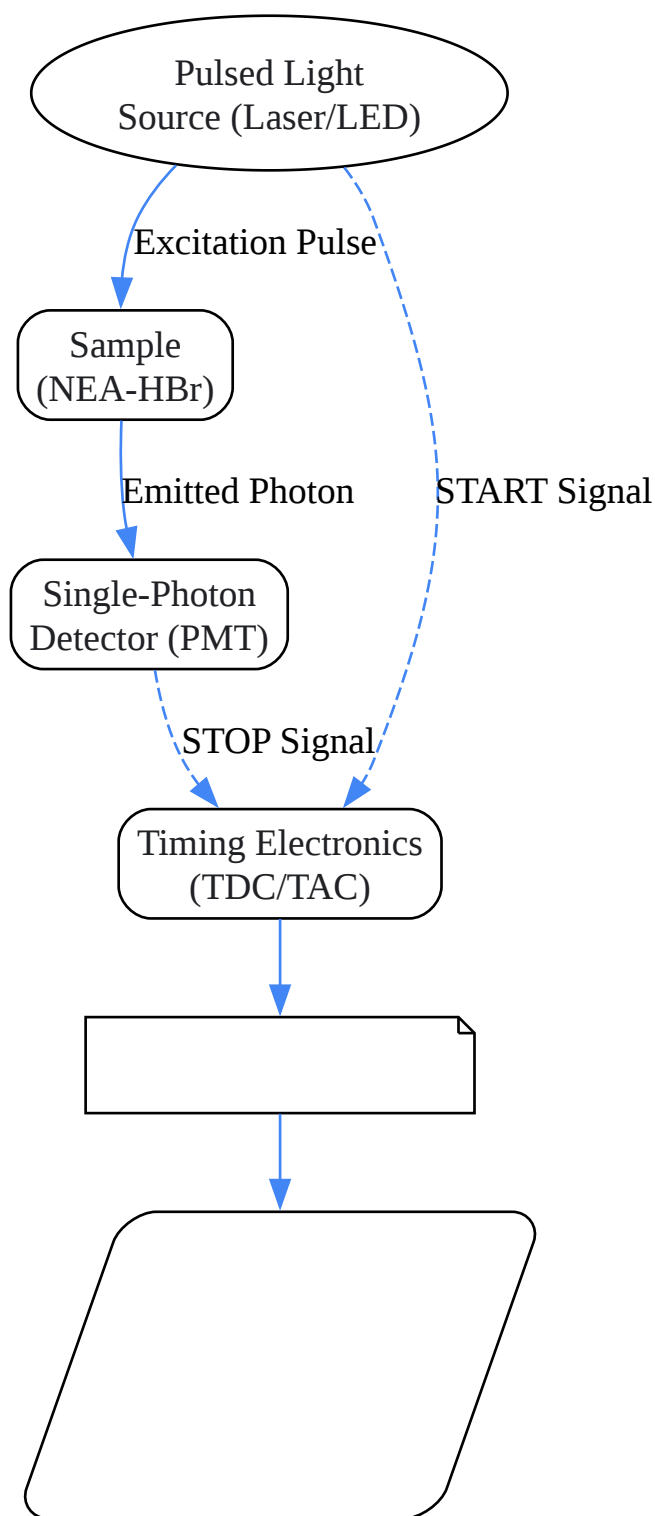

[Click to download full resolution via product page](#)

Caption: Conceptual workflow of a TCSPC experiment.

Part 3: Environmental Sensitivity - NEA as a Probe

The most valuable feature of aminonaphthalene probes is their sensitivity to the environment, a phenomenon known as solvatochromism.

Solvatochromism

Solvatochromism is the change in a substance's absorption or emission spectrum as the polarity of the solvent is changed. For molecules like NEA, the excited state (S_1) has a larger dipole moment than the ground state (S_0). In a polar solvent, the surrounding solvent molecules will reorient themselves to stabilize the more polar excited state. This stabilization lowers the energy of the S_1 state more than the S_0 state, resulting in a red-shift (a shift to longer wavelengths) in the fluorescence emission.

This effect makes NEA a powerful probe. A significant red-shift in its emission spectrum upon binding to a protein, for example, indicates that the binding site is a polar, solvent-accessible environment. Conversely, a blue-shift suggests binding within a non-polar, hydrophobic pocket.

Expected Photophysical Properties of NEA in Various Solvents

Based on extensive data for the parent compound 1-Naphthylamine, we can predict the behavior of NEA.^[9] The following table presents illustrative, expected data to guide experimental work. It is anticipated that as solvent polarity increases, a significant red-shift in emission will be observed, accompanied by a decrease in the fluorescence quantum yield.

Solvent	Dielectric Constant (ϵ)	Expected λ_{abs} (nm)	Expected λ_{em} (nm)	Expected Stokes Shift (cm^{-1})	Expected Φ_F
Cyclohexane	2.02	~320	~385	~5600	~0.40
Dioxane	2.21	~321	~400	~6700	~0.35
Acetonitrile	37.5	~323	~430	~8500	~0.25
Ethanol	24.5	~322	~440	~9100	~0.20
Water	80.1	~325	~470	~10800	~0.10

Disclaimer: This is a table of expected trends based on analogous compounds. These values must be determined empirically following the protocols in Part 2.

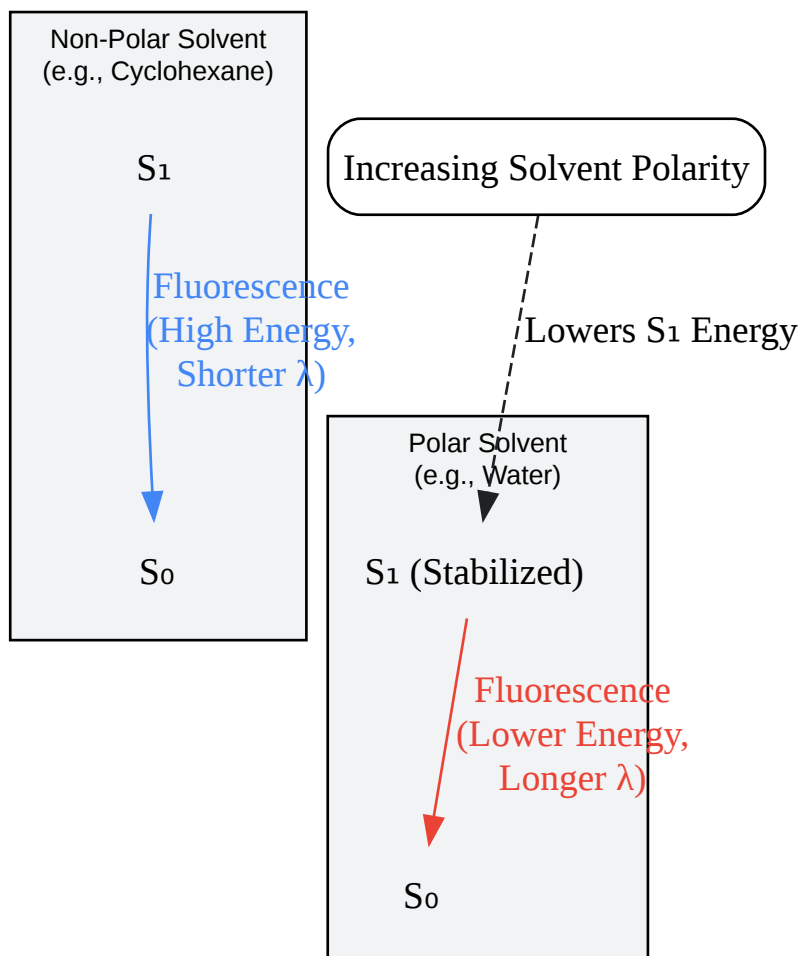

[Click to download full resolution via product page](#)

Need Custom Synthesis?

BenchChem offers custom synthesis for rare earth carbides and specific isotopic labeling.

Email: info@benchchem.com or [Request Quote Online](#).

Sources

- 1. agilent.com [agilent.com]
- 2. horiba.com [horiba.com]

- 3. edinst.com [edinst.com]
- 4. chem.uci.edu [chem.uci.edu]
- 5. pdf.benchchem.com [pdf.benchchem.com]
- 6. Time-correlated single photon counting (TCSPC) [uniklinikum-jena.de]
- 7. photon-force.com [photon-force.com]
- 8. lup.lub.lu.se [lup.lub.lu.se]
- 9. researchgate.net [researchgate.net]
- To cite this document: BenchChem. [photophysical properties of N-Ethyl-1-naphthylamine Hydrobromide]. BenchChem, [2026]. [Online PDF]. Available at: [https://www.benchchem.com/product/b1461567#photophysical-properties-of-n-ethyl-1-naphthylamine-hydrobromide]

Disclaimer & Data Validity:

The information provided in this document is for Research Use Only (RUO) and is strictly not intended for diagnostic or therapeutic procedures. While BenchChem strives to provide accurate protocols, we make no warranties, express or implied, regarding the fitness of this product for every specific experimental setup.

Technical Support: The protocols provided are for reference purposes. Unsure if this reagent suits your experiment? [[Contact our Ph.D. Support Team for a compatibility check](#)]

Need Industrial/Bulk Grade? [Request Custom Synthesis Quote](#)

BenchChem

Our mission is to be the trusted global source of essential and advanced chemicals, empowering scientists and researchers to drive progress in science and industry.

Contact

Address: 3281 E Guasti Rd

Ontario, CA 91761, United States

Phone: (601) 213-4426

Email: info@benchchem.com