

Spectroscopic Characterization of 3,4-Dichlorophenylacetylene: A Technical Guide

Author: BenchChem Technical Support Team. **Date:** May 2026

Compound of Interest

Compound Name: 3,4-Dichlorophenylacetylene

CAS No.: 556112-20-0

Cat. No.: B1461692

[Get Quote](#)

Introduction

3,4-Dichlorophenylacetylene is a halogenated aromatic alkyne of significant interest in synthetic chemistry and materials science. Its rigid structure and reactive acetylene moiety make it a valuable building block for the synthesis of complex organic molecules, including pharmaceuticals, agrochemicals, and conjugated polymers. Accurate structural elucidation and purity assessment of this compound are paramount for its effective application. This technical guide provides an in-depth analysis of the key spectroscopic data—Nuclear Magnetic Resonance (NMR), Infrared (IR), and Mass Spectrometry (MS)—for **3,4-Dichlorophenylacetylene**, offering field-proven insights into data acquisition and interpretation for researchers, scientists, and drug development professionals.

While comprehensive experimental spectra for this specific compound are not readily available in public databases, this guide leverages advanced predictive algorithms and comparative analysis with structurally analogous compounds to provide a robust and scientifically grounded characterization. This approach mirrors the problem-solving methodologies employed in industrial research and development when encountering novel chemical entities.

I. Nuclear Magnetic Resonance (NMR)

Spectroscopy: Probing the Core Structure

NMR spectroscopy is the cornerstone of molecular structure determination in organic chemistry. For **3,4-Dichlorophenylacetylene**, both ^1H and ^{13}C NMR provide unambiguous information about the arrangement of atoms within the molecule.

^1H NMR Spectroscopy: A Window into the Aromatic System

The ^1H NMR spectrum of **3,4-Dichlorophenylacetylene** is characterized by signals in the aromatic and acetylenic regions. The 3,4-dichloro substitution pattern on the benzene ring results in a distinct splitting pattern for the three aromatic protons.

Predicted ^1H NMR Data (500 MHz, CDCl_3)

| Proton Label | Predicted Chemical Shift (ppm) | Predicted Multiplicity | Predicted Coupling Constant (J) in Hz |
|--------------|--------------------------------|------------------------|---------------------------------------|
| H-2 | 7.55 | d | J = 2.0 Hz |
| H-5 | 7.42 | d | J = 8.3 Hz |
| H-6 | 7.28 | dd | J = 8.3, 2.0 Hz |
| Acetylenic-H | 3.05 | s | - |

Causality and Interpretation:

- Aromatic Protons (H-2, H-5, H-6): The chemical shifts of aromatic protons are influenced by the electronic effects of the substituents. The two chlorine atoms are electron-withdrawing, which generally deshields the aromatic protons, causing them to resonate at a lower field (higher ppm) compared to unsubstituted benzene (7.34 ppm)[1]. The alkyne group also exhibits anisotropic effects that influence the surrounding protons. H-2 is expected to be the most downfield-shifted aromatic proton due to its proximity to the deshielding alkyne and a chlorine atom. The observed splitting pattern—a doublet for H-2, a doublet for H-5, and a doublet of doublets for H-6—is characteristic of a 1,2,4-trisubstituted benzene ring.

- **Acetylenic Proton:** The acetylenic proton signal appears as a sharp singlet around 3.05 ppm. This upfield shift compared to aromatic protons is a hallmark of terminal alkynes.

Experimental Protocol for ^1H NMR Data Acquisition:

- **Sample Preparation:** Dissolve approximately 5-10 mg of **3,4-Dichlorophenylacetylene** in ~0.7 mL of deuterated chloroform (CDCl_3). CDCl_3 is a standard solvent for non-polar to moderately polar organic compounds and its residual proton signal at 7.26 ppm provides a convenient internal reference.
- **Instrumentation:** Utilize a 400 MHz or higher field NMR spectrometer. A higher field strength provides better signal dispersion and resolution, which is crucial for resolving the coupling patterns in the aromatic region.
- **Acquisition Parameters:**
 - **Pulse Sequence:** A standard single-pulse experiment (e.g., 'zg30') is sufficient.
 - **Number of Scans:** 16-32 scans should provide an excellent signal-to-noise ratio.
 - **Relaxation Delay (d1):** A delay of 1-2 seconds is typically adequate.
- **Data Processing:** Process the raw data with a Fourier transform, followed by phase and baseline correction. Reference the spectrum to the residual CDCl_3 signal at 7.26 ppm.

Visualization of ^1H NMR Assignments:

Caption: Structure of **3,4-Dichlorophenylacetylene** with proton assignments.

^{13}C NMR Spectroscopy: Mapping the Carbon Skeleton

The proton-decoupled ^{13}C NMR spectrum provides a signal for each unique carbon atom in the molecule, offering a direct count of non-equivalent carbons and information about their chemical environment.

Predicted ^{13}C NMR Data (125 MHz, CDCl_3)

| Carbon Label | Predicted Chemical Shift (ppm) |
|--------------|--------------------------------|
| C-1 | 133.5 |
| C-2 | 132.8 |
| C-3 | 132.5 |
| C-4 | 130.4 |
| C-5 | 129.9 |
| C-6 | 122.3 |
| C≡CH | 83.2 |
| C≡CH | 77.4 |

Causality and Interpretation:

- **Aromatic Carbons (C1-C6):** The six aromatic carbons are chemically non-equivalent and are expected to appear in the typical aromatic region of 120-150 ppm[2]. The carbons directly attached to the chlorine atoms (C-3 and C-4) and the alkyne group (C-1) will have their chemical shifts significantly influenced by these substituents.
- **Alkyne Carbons:** The two sp-hybridized carbons of the alkyne group are predicted to resonate between 70 and 90 ppm[3]. The carbon attached to the aromatic ring (C≡CH) will be further downfield than the terminal acetylenic carbon (C≡CH). It is important to note that quaternary carbons, such as the alkyne carbon attached to the ring, often exhibit lower intensity signals in proton-decoupled spectra.

Experimental Protocol for ¹³C NMR Data Acquisition:

- **Sample Preparation:** Use the same sample prepared for ¹H NMR. A higher concentration (20-50 mg) may be beneficial due to the lower natural abundance of ¹³C.
- **Instrumentation:** A 100 or 125 MHz NMR spectrometer is standard.
- **Acquisition Parameters:**

- Pulse Sequence: A standard proton-decoupled pulse sequence (e.g., 'zgpg30') is used to simplify the spectrum to single lines for each carbon.
- Number of Scans: A larger number of scans (e.g., 1024 or more) is typically required to achieve a good signal-to-noise ratio.
- Relaxation Delay (d1): A 2-second delay is a good starting point.
- Data Processing: Similar to ^1H NMR, the data is processed with a Fourier transform, phasing, and baseline correction. The spectrum is referenced to the CDCl_3 triplet centered at 77.16 ppm[4].

Visualization of NMR Acquisition Workflow:

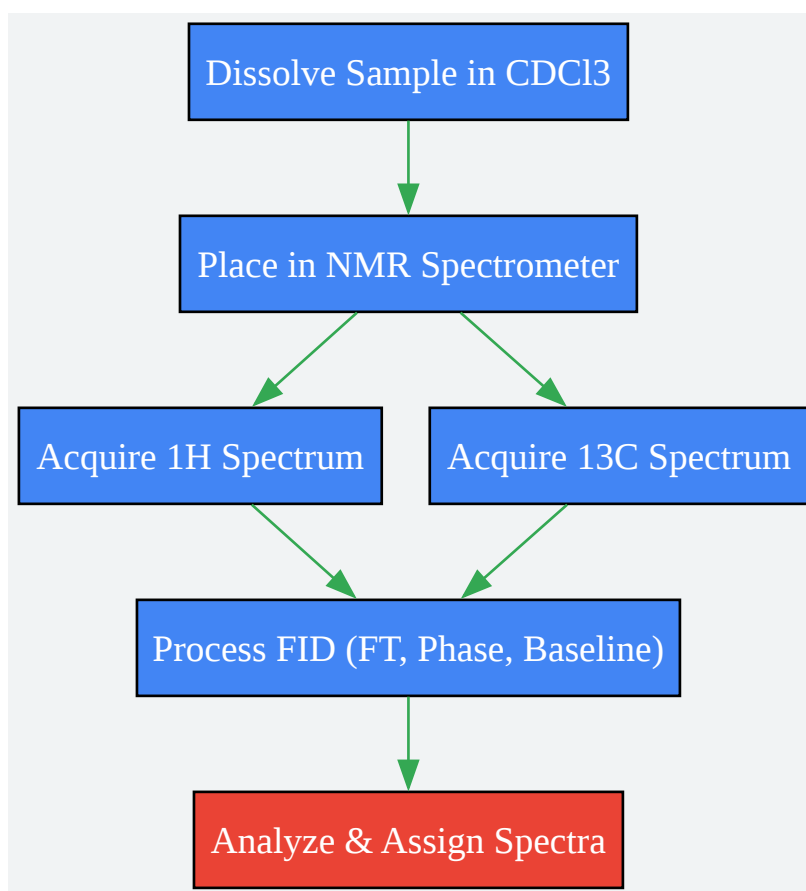

[Click to download full resolution via product page](#)

Caption: Standard workflow for NMR data acquisition and analysis.

II. Infrared (IR) Spectroscopy: Identifying Functional Groups

IR spectroscopy is a rapid and powerful technique for identifying the functional groups present in a molecule by detecting their characteristic vibrational frequencies.

Predicted IR Absorption Frequencies

| Wavenumber (cm ⁻¹) | Vibration Type | Functional Group |
|--------------------------------|-------------------------|---------------------------------|
| ~3300 | C-H Stretch | Terminal Alkyne (\equiv C-H) |
| ~3080 | C-H Stretch | Aromatic (Ar-H) |
| ~2120 | C \equiv C Stretch | Alkyne |
| ~1580, 1470 | C=C Stretch | Aromatic Ring |
| ~880, 820 | C-H Bend (out-of-plane) | Aromatic (substituted) |
| ~1100-1000 | C-Cl Stretch | Aryl Halide |

Causality and Interpretation:

- \equiv C-H Stretch: The most diagnostic peak for a terminal alkyne is the sharp, strong absorption around 3300 cm⁻¹ due to the stretching of the sp-hybridized C-H bond[5].
- C \equiv C Stretch: The carbon-carbon triple bond stretch appears as a sharp, but often weak, absorption around 2120 cm⁻¹. Its intensity can be variable.
- Aromatic C-H and C=C Stretches: Aromatic C-H stretching vibrations are typically observed just above 3000 cm⁻¹[6]. The characteristic C=C stretching vibrations of the benzene ring usually appear as a pair of bands in the 1600-1450 cm⁻¹ region.
- C-Cl Stretch: The carbon-chlorine stretching vibrations for aryl chlorides are found in the fingerprint region, typically between 1100 and 1000 cm⁻¹.

Experimental Protocol for IR Data Acquisition (ATR):

- Instrumentation: A Fourier-Transform Infrared (FT-IR) spectrometer equipped with an Attenuated Total Reflectance (ATR) accessory is ideal for solid samples.
- Sample Preparation: Place a small amount of the solid **3,4-Dichlorophenylacetylene** directly onto the ATR crystal.
- Data Acquisition:
 - Background Scan: First, acquire a background spectrum of the clean, empty ATR crystal. This is crucial to subtract any atmospheric (CO₂, H₂O) or instrumental signals.
 - Sample Scan: Apply pressure to ensure good contact between the sample and the crystal, then acquire the sample spectrum. Typically, 16-32 scans are co-added to improve the signal-to-noise ratio.
- Data Processing: The instrument software automatically ratios the sample spectrum to the background spectrum to generate the final absorbance or transmittance spectrum.

III. Mass Spectrometry (MS): Determining Molecular Weight and Fragmentation

Mass spectrometry provides the molecular weight of a compound and offers structural clues based on its fragmentation pattern. For **3,4-Dichlorophenylacetylene**, the presence of two chlorine atoms creates a highly characteristic isotopic pattern.

Predicted Mass Spectrometry Data (Electron Ionization - EI)

| m/z | Ion | Interpretation |
|-------------|---|---------------------------------|
| 170/172/174 | [C ₈ H ₄ Cl ₂] ⁺ | Molecular Ion (M ⁺) |
| 135/137 | [C ₈ H ₄ Cl] ⁺ | Loss of a Cl atom |
| 100 | [C ₈ H ₄] ⁺ | Loss of two Cl atoms |
| 74/76 | [C ₆ H ₂ Cl] ⁺ | Fragmentation of the ring |
| 50 | [C ₄ H ₂] ⁺ | Smaller fragments |

Causality and Interpretation:

- **Molecular Ion (M^+):** The molecular ion peak is expected at an m/z corresponding to the molecular weight of the compound (171.02 g/mol). Due to the natural abundance of chlorine isotopes ($^{35}\text{Cl} \approx 75\%$, $^{37}\text{Cl} \approx 25\%$), a distinctive pattern will be observed for ions containing chlorine. For a molecule with two chlorine atoms, the M^+ peak will appear at m/z 170 (containing two ^{35}Cl atoms), an $M+2$ peak at m/z 172 (one ^{35}Cl and one ^{37}Cl), and an $M+4$ peak at m/z 174 (two ^{37}Cl atoms). The expected relative intensity ratio of these peaks is approximately 9:6:1, which is a definitive indicator of the presence of two chlorine atoms.
- **Fragmentation Pattern:** Under electron ionization, the molecule will fragment in a predictable manner.
 - **Loss of Chlorine:** A common fragmentation pathway for halogenated aromatic compounds is the loss of a halogen atom. The loss of a chlorine radical will result in a fragment ion at m/z 135/137.
 - **Loss of Acetylene:** The loss of acetylene (C_2H_2) from the molecular ion or subsequent fragments is also a plausible pathway for phenylacetylenes[2].

Experimental Protocol for MS Data Acquisition (GC-MS):

- **Instrumentation:** A Gas Chromatograph coupled to a Mass Spectrometer (GC-MS) with an electron ionization (EI) source is a standard setup for the analysis of volatile and semi-volatile organic compounds.
- **Sample Preparation:** Prepare a dilute solution of the compound (~1 mg/mL) in a volatile organic solvent such as dichloromethane or ethyl acetate.
- **GC Conditions:**
 - **Injection:** Inject 1 μL of the solution into the GC.
 - **Column:** A standard non-polar column (e.g., DB-5ms) is suitable.
 - **Temperature Program:** A temperature gradient (e.g., starting at 50°C and ramping to 250°C) is used to ensure the compound elutes as a sharp peak.

- MS Conditions:
 - Ionization Mode: Electron Ionization (EI) at 70 eV is standard.
 - Mass Range: Scan a mass range from m/z 40 to 300 to ensure capture of the molecular ion and all significant fragments.

Visualization of Key MS Fragmentation:

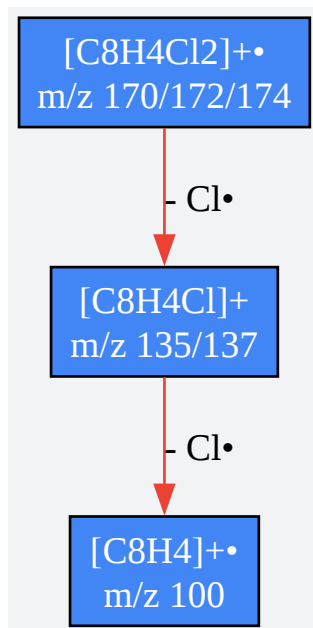

[Click to download full resolution via product page](#)

Caption: Primary fragmentation pathway for **3,4-Dichlorophenylacetylene** in EI-MS.

Conclusion

The spectroscopic characterization of **3,4-Dichlorophenylacetylene** can be effectively achieved through a combination of NMR, IR, and MS techniques. The predicted data, based on established spectroscopic principles and comparison with analogous structures, provides a clear and consistent picture of its molecular structure. The ^1H and ^{13}C NMR spectra confirm the 1,2,4-trisubstituted aromatic ring and the terminal alkyne. The IR spectrum provides definitive evidence for the key functional groups, particularly the acetylenic C-H and C \equiv C bonds. Finally, mass spectrometry confirms the molecular weight and reveals a characteristic isotopic pattern that unambiguously points to the presence of two chlorine atoms. This comprehensive

spectroscopic profile serves as a reliable reference for the identification and quality control of **3,4-Dichlorophenylacetylene** in research and development settings.

References

- Royal Society of Chemistry. (2018). Cross-coupling reactivity of 1,1-dichloroalkenes under palladium catalysis: Domino synthesis of diarylalkynes.
- Abraham, R. J., et al. (n.d.). Proton chemical shifts in NMR. Part 14. Proton chemical shifts, ring currents and π electron effects in condensed aromatic hydrocarbons and substituted benzenes. RSC Publishing.
- Chemistry LibreTexts. (2023, January 29). Interpreting C-13 NMR Spectra. Retrieved from [\[Link\]](#)
- Doc Brown's Chemistry. (n.d.). ¹³C nmr spectrum of 1,1-dichloroethane. Retrieved from [\[Link\]](#)
- University of Colorado Boulder. (n.d.). Table of Characteristic IR Absorptions. Retrieved from [\[Link\]](#)
- Michigan State University. (n.d.). Infrared Spectroscopy. Retrieved from [\[Link\]](#)
- Chemistry LibreTexts. (2023, August 29). Organic Compounds Containing Halogen Atoms. Retrieved from [\[Link\]](#)
- RACO. (n.d.). Synthesis, Biological activity and Mass Spectral Fragmentation Patterns of some New Fused Phthalazine-1,4-dione Derivatives. Retrieved from [\[Link\]](#)
- YouTube. (2022, October 7). chemical shift of functional groups in ¹³C NMR spectroscopy. Retrieved from [\[Link\]](#)

Need Custom Synthesis?

BenchChem offers custom synthesis for rare earth carbides and specific isotopic labeling.

Email: info@benchchem.com or [Request Quote Online](#).

Sources

- [1. 3,4-Dichloronitrobenzene\(99-54-7\) 13C NMR spectrum \[chemicalbook.com\]](#)
- [2. raco.cat \[raco.cat\]](#)
- [3. 4,4'-Dichloro-trans-stilbene | C14H10Cl2 | CID 5352400 - PubChem \[pubchem.ncbi.nlm.nih.gov\]](#)
- [4. 13C nmr spectrum of 1,1-dichloroethane C2H4Cl2 CH3CHCl2 analysis of chemical shifts ppm interpretation of C-13 chemical shifts ppm of 1,1-dichloroethane C13 13-C nmr doc brown's advanced organic chemistry revision notes \[docbrown.info\]](#)
- [5. Download NMR Predict - Mestrelab \[mestrelab.com\]](#)
- [6. 3,4-Dichlorophenylacetylene 97 556112-20-0 \[sigmaaldrich.com\]](#)
- [To cite this document: BenchChem. \[Spectroscopic Characterization of 3,4-Dichlorophenylacetylene: A Technical Guide\]. BenchChem, \[2026\]. \[Online PDF\]. Available at: \[https://www.benchchem.com/product/b1461692/docs#spectroscopic-characterization-of-3-4-dichlorophenylacetylene-a-technical-guide\]](#)

Disclaimer & Data Validity:

The information provided in this document is for Research Use Only (RUO) and is strictly not intended for diagnostic or therapeutic procedures. While BenchChem strives to provide accurate protocols, we make no warranties, express or implied, regarding the fitness of this product for every specific experimental setup.

Technical Support: The protocols provided are for reference purposes. Unsure if this reagent suits your experiment?

Need Industrial/Bulk Grade? [Request Custom Synthesis Quote](#)

BenchChem

Our mission is to be the trusted global source of essential and advanced chemicals, empowering scientists and researchers to drive progress in science and industry.

Contact

Address: 3281 E Guasti Rd
Ontario, CA 91761, United States
Phone: (601) 213-4426
Email: info@benchchem.com

Contact our Ph.D. Support Team for a compatibility check