

Application Notes and Protocols for Acteoside in In Vivo Animal Models

Author: BenchChem Technical Support Team. **Date:** April 2026

Compound of Interest

Compound Name: *Reptoside*

Cat. No.: *B1461693*

[Get Quote](#)

Disclaimer: Due to the limited availability of specific in vivo data for **Reptoside**, these application notes and protocols have been developed based on comprehensive research on Acteoside, a structurally and functionally similar phenylethanoid glycoside. The information provided herein serves as a guide for researchers and professionals in drug development interested in the therapeutic potential of this class of compounds.

Introduction

Acteoside, also known as verbascoside, is a natural phenylpropanoid glycoside that has garnered significant scientific interest for its diverse pharmacological activities. Extensive research in various in vivo animal models has demonstrated its potent neuroprotective and anti-inflammatory properties, suggesting its therapeutic potential for a range of disorders, including neurodegenerative diseases and inflammatory conditions. These notes provide a summary of key findings and detailed protocols for the application of Acteoside in preclinical research.

Data Presentation: Efficacy of Acteoside in Animal Models

The following tables summarize the quantitative data from various in vivo studies, showcasing the therapeutic efficacy of Acteoside across different animal models.

Table 1: Neuroprotective Effects of Acteoside

Animal Model	Disease/Injury Model	Species	Acteoside Dosage & Administration	Key Findings
Parkinson's Disease	Rotenone-induced	Rat	Oral administration	Significantly attenuated parkinsonism symptoms and inhibited rotenone-induced α -synuclein and caspase-3 upregulation.[1]
Parkinson's Disease	6-hydroxydopamine (6-OHDA)-induced	Zebrafish	Pretreatment	Prevented 6-OHDA-stimulated movement disorders and dopaminergic neuron death.[2]
Parkinson's Disease	Rotenone-induced	Drosophila melanogaster	Treatment	Exerted significant neuroprotection effects against rotenone-induced injury.[3] [4]
Glaucoma	Spontaneous model	DBA/2J Mouse	18 mg/mL in drinking water (gavage)	Decreased intraocular pressure, improved retinal wave amplitudes, and increased retinal thickness and cell numbers

				in the ganglion cell layer.[5][6]
Alzheimer's Disease	Amyloid β peptide 1-42 (A β 1-42)-infused	Rat	Not specified	Ameliorated cognitive deficits and decreased amyloid deposition.[7]
Cerebral Ischemia-Reperfusion	Focal cerebral ischemia	Rat	Not specified	Reduced infarct volume, brain edema, and improved neurological deficits.[8]

Table 2: Anti-inflammatory Effects of Acteoside

Animal Model	Disease/Injury Model	Species	Acteoside Dosage & Administration	Key Findings
Colitis	Dextran sulphate sodium (DSS)-induced	Mouse	120 or 600 μ g/mouse/day (intraperitoneal)	Significantly ameliorated colitis, with improved histological scores.[9][10]
Colitis	Chemically induced	Mouse	Oral administration	Ameliorated intestinal inflammation and oxidative stress. [11]
Osteoarthritis	Surgery-induced	Rat	Treatment	Markedly reduced the production of inflammatory cytokines (IL-1 β , IL-6, IL-12, TNF- α , IFN- γ) in synovial fluid.[12] [13]
Acute Lung Injury	Lipopolysaccharide (LPS)-induced	Mouse	30 and 60 mg/kg (intraperitoneal)	Significantly decreased lung wet-to-dry weight ratio and myeloperoxidase activity.[14]

Table 3: Pharmacokinetics and Toxicity of Acteoside

Species	Administration Route	Key Pharmacokinetic Parameters	Acute Toxicity (LD50)
Rat	Oral (100 mg/kg)	Cmax: 0.13 µg/mL, Bioavailability: 0.12% [15]	Oral: >5000 mg/kg[16]
Rat	Intravenous (3 mg/kg)	Cmax: 48.6 µg/mL[15]	Intraperitoneal: >5000 mg/kg[16]
Dog	Oral (10, 20, 40 mg/kg)	Tmax: 30-45 min, T1/2: ~90 min, Dose-proportional exposure	Not specified

Experimental Protocols

The following are detailed methodologies for key experiments cited in the application of Acteoside.

Protocol 1: Evaluation of Neuroprotective Effects in a Rat Model of Parkinson's Disease

1. Animal Model:

- Species: Male Sprague-Dawley rats.
- Induction of Parkinsonism: Administer Rotenone (e.g., 2.5 mg/kg, intraperitoneally) daily for a specified period (e.g., 4 weeks) to induce progressive neurodegeneration.

2. Acteoside Administration:

- Dosage: Based on dose-response studies, a typical oral dose is in the range of 30-100 mg/kg/day.
- Vehicle: Dissolve Acteoside in a suitable vehicle such as saline or distilled water.

- Administration: Administer orally via gavage daily, either concurrently with or as a pre-treatment to Rotenone administration.

3. Behavioral Assessment:

- Open Field Test: To assess locomotor activity and anxiety-like behavior.
- Rotarod Test: To evaluate motor coordination and balance.
- Cylinder Test: To measure forelimb akinesia.

4. Endpoint Analysis:

- Immunohistochemistry: Sacrifice animals at the end of the treatment period and collect brain tissue. Perform immunohistochemical staining for tyrosine hydroxylase (TH) to quantify the loss of dopaminergic neurons in the substantia nigra. Also, stain for α -synuclein to assess protein aggregation.
- Western Blot: Analyze protein levels of key markers such as caspase-3 (apoptosis), and MAP2 (neuronal integrity) in brain tissue homogenates.^[1]

Protocol 2: Assessment of Anti-inflammatory Effects in a Mouse Model of Colitis

1. Animal Model:

- Species: BALB/c mice.
- Induction of Colitis: Administer 3-5% Dextran Sulphate Sodium (DSS) in the drinking water for 5-7 days to induce acute colitis. For chronic colitis models, multiple cycles of DSS administration can be employed.

2. Acteoside Administration:

- Dosage: 120 or 600 μ g/mouse/day .^{[9][10]}
- Administration: Administer intraperitoneally daily during and/or after DSS exposure.

3. Clinical Assessment:

- Disease Activity Index (DAI): Monitor daily for changes in body weight, stool consistency, and presence of blood in the stool.
- Colon Length: At the end of the study, measure the length of the colon as an indicator of inflammation.

4. Endpoint Analysis:

- Histology: Collect colon tissue, fix in formalin, and embed in paraffin. Stain sections with Hematoxylin and Eosin (H&E) to assess mucosal damage, inflammatory cell infiltration, and crypt architecture.
- Cytokine Analysis: Isolate mesenteric lymph nodes (MLNs) and culture the cells. Stimulate with anti-CD3 and measure the levels of pro-inflammatory cytokines (e.g., IFN- γ , TNF- α , IL-6) in the supernatant using ELISA or multiplex bead assays.[\[9\]](#)

Signaling Pathways and Experimental Workflows

The following diagrams, generated using the DOT language, illustrate the key signaling pathways modulated by Acteoside and a typical experimental workflow.

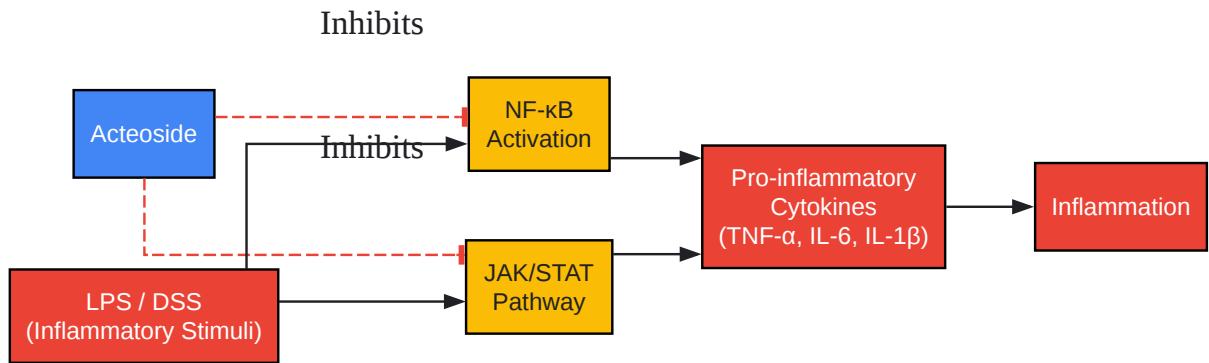
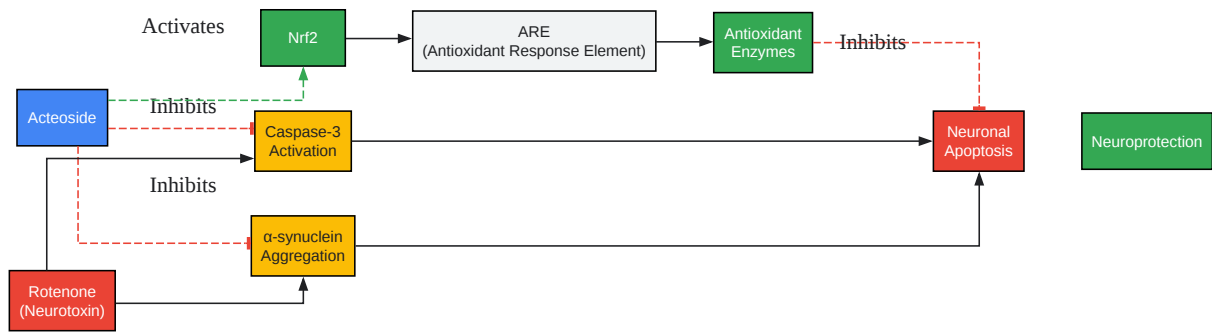

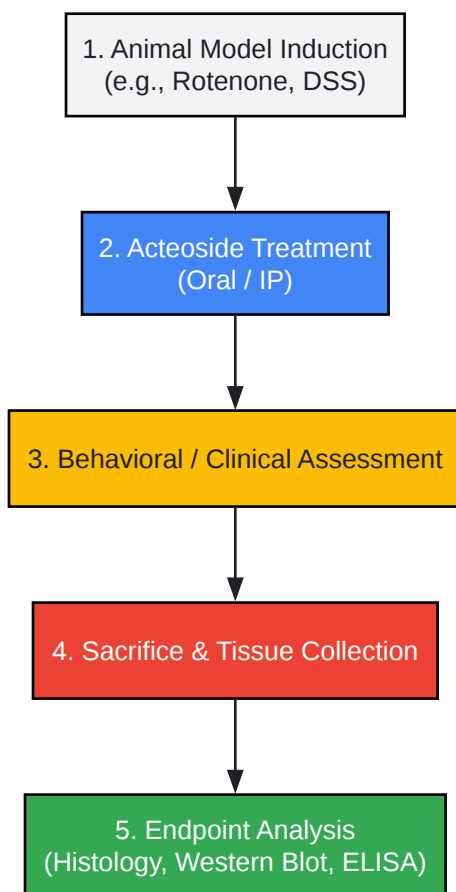

[Click to download full resolution via product page](#)

Need Custom Synthesis?

BenchChem offers custom synthesis for rare earth carbides and specific isotopic labeling.

Email: info@benchchem.com or [Request Quote Online](#).

References

- [1. Acteoside Binds to Caspase-3 and Exerts Neuroprotection in the Rotenone Rat Model of Parkinson's Disease - PMC \[pmc.ncbi.nlm.nih.gov\]](#)
- [2. Acteoside protects against 6-OHDA-induced dopaminergic neuron damage via Nrf2-ARE signaling pathway - PubMed \[pubmed.ncbi.nlm.nih.gov\]](#)
- [3. researchgate.net \[researchgate.net\]](#)
- [4. Acteoside exerts neuroprotection effects in the model of Parkinson's disease via inducing autophagy: Network pharmacology and experimental study - PubMed](#)

[pubmed.ncbi.nlm.nih.gov]

- 5. Neuroprotective effects of acteoside in a glaucoma mouse model by targeting Serta domain-containing protein 4 - PMC [pmc.ncbi.nlm.nih.gov]
- 6. Neuroprotective effects of acteoside in a glaucoma mouse model by targeting Serta domain-containing protein 4 - PubMed [pubmed.ncbi.nlm.nih.gov]
- 7. Acteoside and Isoacteoside Protect Amyloid β Peptide Induced Cytotoxicity, Cognitive Deficit and Neurochemical Disturbances In Vitro and In Vivo [mdpi.com]
- 8. Acteoside Attenuates Oxidative Stress and Neuronal Apoptosis in Rats with Focal Cerebral Ischemia–Reperfusion Injury [jstage.jst.go.jp]
- 9. In vivo treatment with the herbal phenylethanoid acteoside ameliorates intestinal inflammation in dextran sulphate sodium-induced colitis - PMC [pmc.ncbi.nlm.nih.gov]
- 10. academic.oup.com [academic.oup.com]
- 11. Acteoside, the Main Bioactive Compound in Osmanthus fragrans Flowers, Palliates Experimental Colitis in Mice by Regulating the Gut Microbiota - PubMed [pubmed.ncbi.nlm.nih.gov]
- 12. Acteoside inhibits inflammatory response via JAK/STAT signaling pathway in osteoarthritic rats - PMC [pmc.ncbi.nlm.nih.gov]
- 13. researchgate.net [researchgate.net]
- 14. Effects of acteoside on lipopolysaccharide-induced inflammation in acute lung injury via regulation of NF- κ B pathway in vivo and in vitro - PubMed [pubmed.ncbi.nlm.nih.gov]
- 15. The pharmacokinetic property and pharmacological activity of acteoside: A review - PMC [pmc.ncbi.nlm.nih.gov]
- 16. Multifaceted Biological Properties of Verbascoside/Acteoside: Antimicrobial, Cytotoxic, Anti-Inflammatory, and Immunomodulatory Effects - PMC [pmc.ncbi.nlm.nih.gov]
- To cite this document: BenchChem. [Application Notes and Protocols for Acteoside in In Vivo Animal Models]. BenchChem, [2026]. [Online PDF]. Available at: [https://www.benchchem.com/product/b1461693/docs#application-notes-and-protocols-for-acteoside-in-in-vivo-animal-models]

Disclaimer & Data Validity:

The information provided in this document is for Research Use Only (RUO) and is strictly not intended for diagnostic or therapeutic procedures. While BenchChem strives to provide

accurate protocols, we make no warranties, express or implied, regarding the fitness of this product for every specific experimental setup.

Technical Support: The protocols provided are for reference purposes. Unsure if this reagent suits your experiment?

Need Industrial/Bulk Grade? [Request Custom Synthesis Quote](#)

BenchChem

Our mission is to be the trusted global source of essential and advanced chemicals, empowering scientists and researchers to drive progress in science and industry.

Contact

Address: 3281 E Guasti Rd

Ontario, CA 91761, United States

Phone: (601) 213-4426

Email: info@benchchem.com

[Contact our Ph.D. Support Team for a compatibility check](#)