

Spectral Characterization and Photochemical Dynamics of 2-Azidoanthracene: A Technical Guide

Author: BenchChem Technical Support Team. **Date:** April 2026

Compound of Interest

Compound Name:	2-Azidoanthracene
CAS No.:	58399-84-1
Cat. No.:	B14605330

[Get Quote](#)

Executive Summary

2-Azidoanthracene (2N3-AN) is a highly versatile, photoactive aromatic compound utilized extensively in click chemistry, polymer functionalization, and the photochemical generation of nitrogen gas layers. As a Senior Application Scientist, understanding the spectral signatures of 2N3-AN is critical for validating its synthesis and monitoring its photolytic decomposition. This whitepaper provides an in-depth, self-validating framework for the spectral characterization of 2N3-AN, detailing the causality behind its UV-Vis, FT-IR, and ^1H NMR profiles.

Chemical Causality & Orthogonal Spectral Validation

A robust analytical workflow requires orthogonal techniques. UV-Vis spectroscopy confirms the extended π -conjugation, Infrared (IR) spectroscopy definitively proves the presence of the intact azide functional group, and Nuclear Magnetic Resonance (NMR) maps the precise regiochemistry of the anthracene core.

UV-Visible Spectroscopy & Photolysis Dynamics

Unsubstituted anthracene absorbs strongly in the UV region. However, the addition of the 2-azido group extends the conjugated system. The azide moiety ($-N_3$) exerts an inductive effect that lowers the HOMO-LUMO gap of the aromatic core.

This electronic perturbation results in a distinct bathochromic (red) shift, producing a new, highly diagnostic absorption peak at 394 nm (1)[1]. Because this peak extends into the near-UV region, 2N3-AN is highly susceptible to photolysis using inexpensive 365 nm or 405 nm diode lasers. During photolysis, the 394 nm peak rapidly decays, and the emergence of clear isosbestic points at 360 nm and 405 nm confirms a clean, single-step photochemical conversion from the azide to a reactive nitrene intermediate (2)[2].

Table 1: UV-Vis Absorption Data (in Chloroform)

Parameter	Value / Observation	Mechanistic Cause
λ_{max} (Primary)	~394 nm	Inductive effect of $-N_3$ conjugated to the anthracene ring.
Isosbestic Points	360 nm, 405 nm	Single-step photolysis without intermediate buildup.

| Photoproduct Absorption | Broad (Visible Region) | Formation of complex brown nitrene dimers/insertion products. |

Infrared (FT-IR) Vibrational Analysis

Infrared spectroscopy provides the most definitive confirmation of the intact azide moiety. The linear, pseudo-cumulenic structure of the azide group ($-N=N^+=N^-$) exhibits a highly characteristic asymmetric stretching vibration.

For 2N3-AN, this stretch manifests as a strong, sharp absorption band at 2109–2116 cm^{-1} (3) [3]. Because very few other functional groups absorb in this specific region (the "IR transparent window"), the presence of this peak is the gold standard for validating the ground-state molecule.

Table 2: Key FT-IR Assignments (KBr Pellet)

Wavenumber (cm ⁻¹)	Vibrational Mode	Diagnostic Significance
2109 – 2116	-N ₃ Asymmetric Stretch	Confirms intact azide group; disappears upon photolysis.

| ~1600, 1450 | C=C Aromatic Stretch | Confirms the structural integrity of the anthracene core.

Nuclear Magnetic Resonance (¹H NMR)

Proton NMR elucidates the precise regiochemistry of the azide substitution. The extended, planar π -system of the anthracene core generates a massive diamagnetic ring current, heavily deshielding the attached protons. In DMSO-d₆, the meso protons (positions 9 and 10) experience the combined anisotropic effects of the adjacent rings and appear furthest downfield as distinct singlets at 8.58 ppm and 8.52 ppm ([Synthesis Journal](glucose sensors)) [3].

Table 3: ¹H NMR Chemical Shifts (300/400 MHz, DMSO-d₆)

Chemical Shift (δ , ppm)	Multiplicity & Integration	Assignment / Environment
8.58	Singlet, 1H	Meso proton (H-9 or H-10), highly deshielded.
8.52	Singlet, 1H	Meso proton (H-10 or H-9), highly deshielded.
8.17	Doublet (J = 8.7 Hz), 3H	Alpha/Beta aromatic protons.
7.79	Singlet, 1H	Proton adjacent to the -N ₃ group (H-1).

| 7.52, 7.28, 7.13 | Doublets, 1H each | Remaining aromatic protons on the substituted ring. |

Standardized Experimental Protocols

To ensure reproducibility and prevent artifactual data, the following self-validating protocols must be strictly adhered to.

Step 1: Sample Preparation (Strict Low-Light)

- Causality: The azide moiety is intrinsically photolabile. Ambient laboratory lighting contains sufficient near-UV photons to trigger premature nitrogen extrusion, compromising the spectral baseline.
- Protocol: Dissolve purified 2N3-AN in HPLC-grade chloroform (for UV-Vis) or DMSO-d₆ (for NMR) in amber vials or under red-light conditions to ensure the ground-state molecule remains intact prior to analysis (1)[1].

Step 2: UV-Vis and Photolysis Monitoring

- Protocol: Transfer the chloroform solution to a 1 cm path length quartz cuvette. Record the steady-state baseline using a dual-beam spectrophotometer. To monitor photodynamics, irradiate the sample with a 365 nm LED source (e.g., 5-9 mW/cm²) and collect spectra at 1-second intervals (2)[2].
- Validation: The emergence of isosbestic points confirms a controlled reaction without side-product interference.

Step 3: FT-IR Spectroscopy

- Protocol: Prepare a solid-state sample by triturating 1-2 mg of 2N3-AN with 100 mg of anhydrous KBr. Press into a translucent pellet under 10 tons of pressure. Scan from 4000 to 400 cm⁻¹ at a resolution of 4 cm⁻¹.
- Validation: Confirm the presence of the 2109–2116 cm⁻¹ asymmetric stretch. The absence of broad O-H stretching (~3300 cm⁻¹) validates sample dryness.

Step 4: ¹H NMR Spectroscopy

- Protocol: Transfer the DMSO-d₆ solution to a standard 5 mm NMR tube. Acquire spectra on a 400 MHz spectrometer at 298 K using a standard proton pulse sequence with 16-64 scans to ensure a high signal-to-noise ratio.

- Validation: Integrate the signals to confirm the 9-proton count corresponding to the 2-substituted anthracene core.

Visualizing Workflows and Pathways

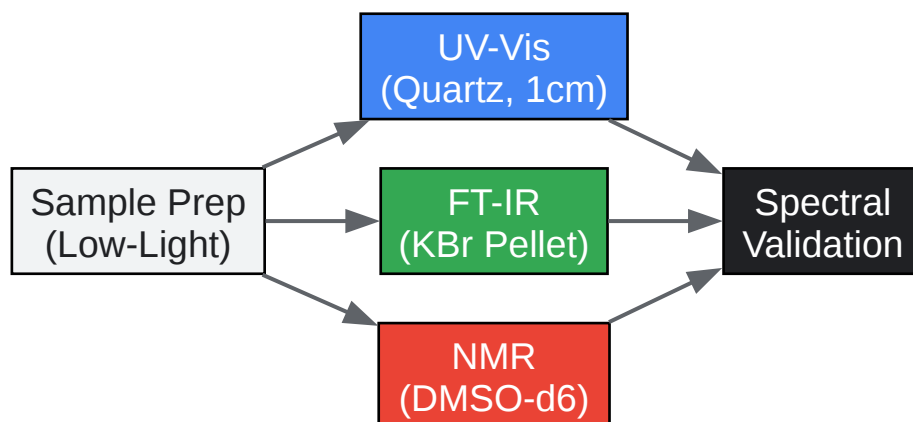

[Click to download full resolution via product page](#)

Self-validating experimental workflow for the spectral characterization of **2-Azidoanthracene**.

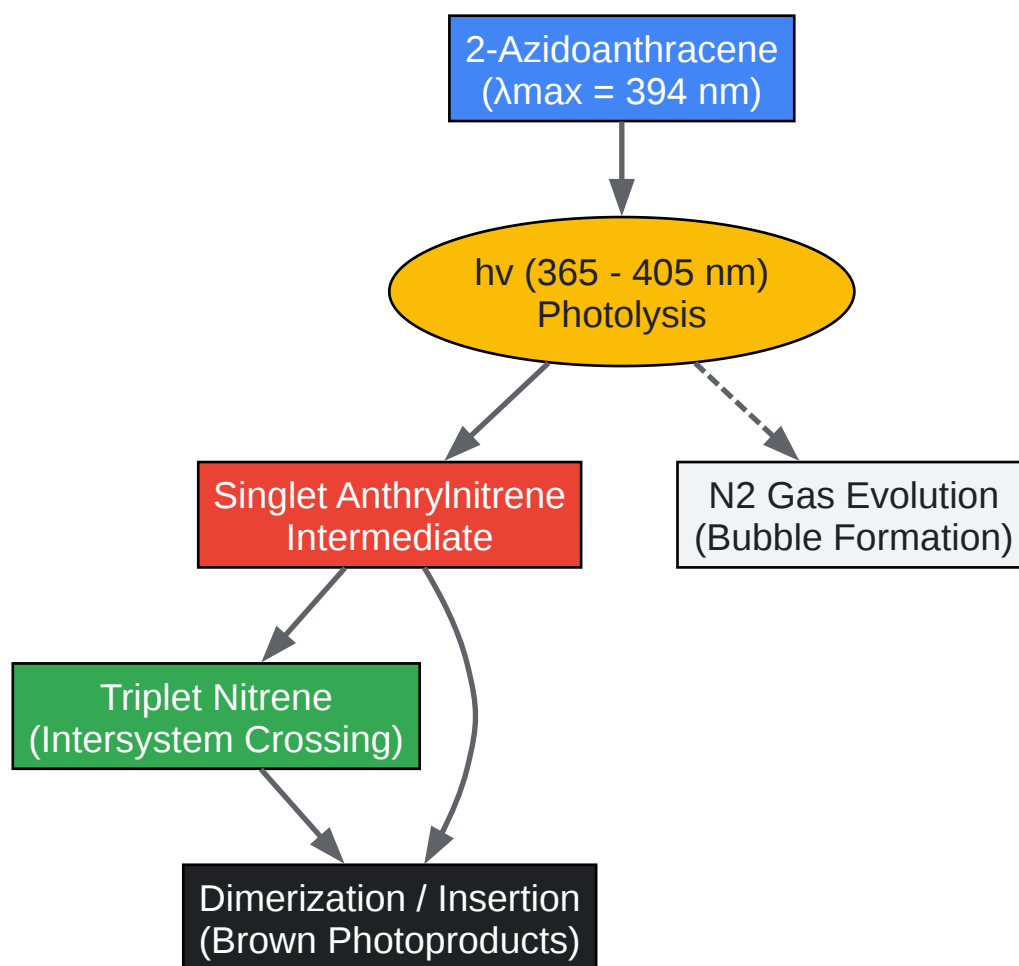

[Click to download full resolution via product page](#)

Photochemical decomposition pathway of **2-Azidoanthracene** upon UV irradiation.

References

- Generating Stable Nitrogen Bubble Layers on Poly(methyl methacrylate) Films by Photolysis of **2-Azidoanthracene** Source: Langmuir (ACS Publications) URL:[1](#)
- One-Pot Preparation of Aryl Azides from Aromatic Amines Source: SYNTHESIS Journal URL:[3](#)
- Photochemical Bubble Generation from Polymer Films: Dependence on Molecular Structure and Application for Ultrasound Imaging Source: SCILTP URL:[2](#)

Need Custom Synthesis?

BenchChem offers custom synthesis for rare earth carbides and specific isotopic labeling.

Email: info@benchchem.com or [Request Quote Online](#).

Sources

- [1. pubs.acs.org](https://pubs.acs.org) [pubs.acs.org]
- [2. media.sciltp.com](https://media.sciltp.com) [media.sciltp.com]
- [3. portal.tpu.ru](https://portal.tpu.ru) [portal.tpu.ru]
- To cite this document: BenchChem. [Spectral Characterization and Photochemical Dynamics of 2-Azidoanthracene: A Technical Guide]. BenchChem, [2026]. [Online PDF]. Available at: [<https://www.benchchem.com/product/b14605330/docs#spectral-characterization-and-photochemical-dynamics-of-2-azidoanthracene-a-technical-guide>]

Disclaimer & Data Validity:

The information provided in this document is for Research Use Only (RUO) and is strictly not intended for diagnostic or therapeutic procedures. While BenchChem strives to provide accurate protocols, we make no warranties, express or implied, regarding the fitness of this product for every specific experimental setup.

Technical Support: The protocols provided are for reference purposes. Unsure if this reagent suits your experiment?

Need Industrial/Bulk Grade? [Request Custom Synthesis Quote](#)

BenchChem

Our mission is to be the trusted global source of essential and advanced chemicals, empowering scientists and researchers to drive progress in science and industry.

Contact

Address: 3281 E Guasti Rd

Ontario, CA 91761, United States

Phone: (601) 213-4426

Email: info@benchchem.com

Contact our Ph.D. Support Team for a compatibility check