

Technical Support Center: Complex Twinning in Microcline

Author: BenchChem Technical Support Team. **Date:** May 2026

Compound of Interest

Compound Name:	Microcline
CAS No.:	60958-71-6
Cat. No.:	B14602288

[Get Quote](#)

This technical support center provides troubleshooting guides and frequently asked questions (FAQs) for researchers, scientists, and drug development professionals encountering complex twinning in microcline during their experiments.

Frequently Asked Questions (FAQs)

Q1: What is complex twinning in microcline?

A1: Complex twinning in microcline refers to the intergrowth of two different types of polysynthetic twins within a single crystal.^[1] This typically involves the Albite twin law, with a twin plane of {010}, and the Pericline twin law, which has a twin axis of^[2].^[3]^[4] The combination of these two twin laws, often intersecting at nearly 90°, produces a characteristic cross-hatched or "tartan" pattern when viewed under a polarizing microscope.^[1]^[5]

Q2: Why does this complex twinning occur in microcline?

A2: This distinctive twinning is commonly the result of a structural transformation.^[1] At high temperatures, potassium feldspar exists as the monoclinic polymorph, sanidine or orthoclase. As it cools slowly, it undergoes a phase transition to the lower-temperature, triclinic polymorph,

microcline.[1][6] This change in symmetry induces the formation of both Albite and Pericline twins to relieve internal strain.[1]

Q3: What is the significance of observing "tartan" twinning?

A3: The presence of "tartan" twinning is a key diagnostic feature for identifying microcline.[1][5] The texture and scale of the twinning (e.g., fine versus coarse lamellae) can also provide insights into the cooling history and thermal state of the host rock.[7][8]

Q4: Can microcline exist without this twinning?

A4: Yes, while "tartan" twinning is characteristic, microcline can also be untwinned or show only one of the twin laws.[7][9] The absence of visible twinning does not rule out the mineral being microcline, and other analytical methods may be needed for definitive identification.

Troubleshooting Guides & Experimental Protocols

This section provides detailed methodologies and troubleshooting for common analytical techniques used to resolve complex twinning in microcline.

Polarized Light Optical Microscopy (PLOM)

Experimental Protocol:

- **Sample Preparation:** Prepare a standard petrographic thin section of the rock or mineral sample, typically 30 μm thick.
- **Initial Observation (Plane-Polarized Light - PPL):**
 - Observe the mineral under PPL to assess its clarity, color (typically colorless), and the presence of any inclusions or alteration.[10]
 - Note the cleavage; microcline has two good cleavages intersecting at approximately 90.4°. [5]
- **Crossed-Polarized Light (XPL) Analysis:**
 - Engage the analyzer to view the sample under XPL.

- Identify microcline by its characteristic first-order gray to white interference colors.[10]
- Look for the distinctive "tartan" or cross-hatched twinning pattern. The two sets of twin lamellae will extinguish at different angles.[1][5]
- Extinction Angle Measurement:
 - Rotate the stage to determine the extinction angles of the different twin sets relative to the cleavage planes. This can be challenging due to the fine and complex nature of the twinning.[9]

Troubleshooting:

- Q: Why is the "tartan" twinning pattern indistinct or "blurry"?
 - A: The twin lamellae may be extremely fine, requiring high magnification to resolve.[7] A "wavy" or uneven extinction can also result from very fine, sub-microscopic twinning.[7] Additionally, the thin section may be too thick, or the crystal may be oriented in a way that does not clearly show the cross-hatching.
- Q: One set of twins is visible, but not the other. Why?
 - A: The crystal may be cut in an orientation that makes one set of twins parallel or nearly parallel to the microscope stage, making them difficult to see.[11] It is also possible that one twin law is poorly developed in that particular crystal.[7]
- Q: How can I differentiate microcline from plagioclase feldspar, which also shows twinning?
 - A: Plagioclase typically shows only one set of polysynthetic twins (Albite law), which appear as parallel stripes.[9] In contrast, microcline's "tartan" pattern is due to two intersecting sets of twins (Albite and Pericline).[9]

X-ray Diffraction (XRD)

Experimental Protocol:

- Sample Preparation: The sample should be finely ground to a powder (ideally <10 μm) to ensure random orientation of the crystallites.[12]

- Data Acquisition:
 - Mount the powdered sample in a standard holder.
 - Run the sample in a powder X-ray diffractometer over a specified 2θ range (e.g., 5-65°).
- Data Analysis:
 - Identify the mineral phase by comparing the resulting diffraction pattern to a database (e.g., ICDD).
 - For twinned microcline, peak splitting or broadening may be observed. The separation of certain peaks can be used to determine the degree of triclinicity (deviation from monoclinic symmetry), which is related to the twinning.
 - Rietveld refinement can be used for quantitative analysis of mixtures containing microcline and to refine its lattice parameters.[\[13\]](#)

Troubleshooting:

- Q: My diffraction peaks are broad or show asymmetry. Is this due to twinning?
 - A: It can be. The presence of multiple twin domains with slightly different orientations can lead to peak broadening and asymmetry. However, small crystallite size and lattice strain can cause similar effects. Careful analysis of peak shapes is required.
- Q: How can I resolve overlapping peaks from different twin domains?
 - A: High-resolution diffraction data and specialized software for peak deconvolution may be necessary. For complex cases, single-crystal XRD is more suitable for separating the diffraction patterns of individual twin domains.[\[14\]](#)[\[15\]](#)
- Q: The XRD pattern matches both microcline and orthoclase. How can I distinguish them?
 - A: While their patterns are similar, subtle differences exist. Microcline (triclinic) will show splitting of certain peaks that are single in orthoclase (monoclinic). For example, the (131) and (1-31) reflections are separated in microcline but overlap in orthoclase.

Electron Backscatter Diffraction (EBSD)

Experimental Protocol:

- **Sample Preparation:** This is a critical step. The sample surface must be exceptionally well-polished and free from mechanical damage, as the EBSD signal originates from the top few nanometers of the surface.[\[16\]](#)[\[17\]](#)
 - Cut and mount the sample in a puck.
 - Grind the sample using progressively finer abrasive papers.[\[18\]](#)
 - Mechanically polish using diamond suspensions (e.g., 9 μm down to 1 μm).
 - Perform a final chemo-mechanical polish using a colloidal silica suspension (e.g., 0.05 μm) for several hours to remove the damaged surface layer.[\[18\]](#)[\[19\]](#)
 - Apply a thin carbon coat to prevent charging in the SEM if the sample is non-conductive.
- **Data Acquisition:**
 - Place the prepared sample in an SEM equipped with an EBSD detector.
 - Tilt the sample to approximately 70°.
 - Collect EBSD patterns (Kikuchi bands) from a grid of points across the area of interest.
- **Data Analysis:**
 - The EBSD software indexes each pattern to determine the crystal orientation at that point.
 - Generate orientation maps to visualize the twin domains. Different colors can be assigned to different crystallographic orientations, clearly delineating the Albite and Pericline twins.
 - Analyze the misorientation angles and axes between adjacent domains to confirm the twin laws.

Troubleshooting:

- Q: I am getting poor quality or un-indexed Kikuchi patterns. What is the problem?
 - A: This is most often due to inadequate sample preparation.[16] A damaged or deformed surface layer will prevent the formation of clear diffraction patterns. Re-polishing, particularly with colloidal silica, is recommended. Charging of non-conductive samples can also degrade pattern quality.[20]
- Q: The EBSD map shows many randomly mis-indexed points ("checkerboard" pattern). How can I fix this?
 - A: This can be an artifact of systematic mis-indexing, especially in materials with low symmetry like feldspars.[21] Ensure the correct crystal structure file is being used for indexing. Adjusting the indexing parameters (e.g., number of bands used) may help. Post-processing routines can be used to clean up the data by removing isolated mis-indexed pixels.
- Q: Why is it difficult to differentiate between different feldspar phases with similar crystal structures?
 - A: Phases with similar crystal structures and lattice parameters can be challenging for automated indexing routines.[22] Combining EBSD with chemical analysis (e.g., Energy Dispersive X-ray Spectroscopy - EDS) can help differentiate phases based on their elemental composition.[22]

Transmission Electron Microscopy (TEM)

Experimental Protocol:

- Sample Preparation:
 - Prepare an electron-transparent foil from the area of interest. This is commonly done using a Focused Ion Beam (FIB) instrument, which allows for precise site-specific sample extraction.[23]
- Imaging:
 - Use bright-field and dark-field imaging to visualize the twin lamellae and their boundaries.

- High-Resolution TEM (HRTEM) can be used to image the crystal lattice directly at the twin boundaries.
- Diffraction:
 - Obtain Selected Area Electron Diffraction (SAED) patterns from individual twin domains and across twin boundaries. The splitting of diffraction spots will reveal the precise crystallographic relationship between the twinned regions.
- Low-Dose Techniques:
 - Feldspars can be sensitive to the electron beam, leading to amorphization.[23][24] It is crucial to use low-dose techniques, such as using a lower accelerating voltage or a sensitive detector, and minimizing exposure time to limit radiation damage.[25][26][27]

Troubleshooting:

- Q: My sample is becoming damaged or amorphous under the electron beam. What can I do?
 - A: This is a common issue with beam-sensitive materials like feldspars.[24] Reduce the electron dose by using a lower beam current, spreading the beam, or using a more sensitive camera with shorter exposure times.[25] Cryo-TEM (cooling the sample with liquid nitrogen) can also significantly reduce beam damage.
- Q: It is difficult to distinguish the twin boundaries clearly in the TEM image.
 - A: Use diffraction contrast imaging. By tilting the sample, you can find a condition where one set of twin domains is strongly diffracting (appearing dark in a bright-field image) while the other is not, which enhances the contrast between them.
- Q: How do I confirm the specific twin law using TEM?
 - A: This is done through analysis of SAED patterns taken across a twin boundary. The pattern will show two superimposed diffraction patterns. By indexing these patterns, you can determine the precise rotation axis or mirror plane that relates them, thus confirming the twin law.

Quantitative Data Summary

Parameter	Typical Value / Description	Source
Twin Laws	Albite Law (Twin Plane: {010}) & Pericline Law (Twin Axis:[2])	[3][4]
Twinning Pattern	"Tartan" or "Gridiron" cross-hatching	[1][5]
Intersection Angle	Lamellae are often nearly at right angles.	[4]
Lamellae Width	Highly variable; can range from sub-micrometer to several micrometers.	[7][28][29]
Crystal System	Triclinic	[5]
Cleavage	Perfect on {001}, Good on {010}; intersecting at ~90.4°	[5]
Birefringence	Low, up to first-order white (approx. 0.007)	[5]
2V Angle	65-88°, Biaxial (-)	[9]

Visualizations

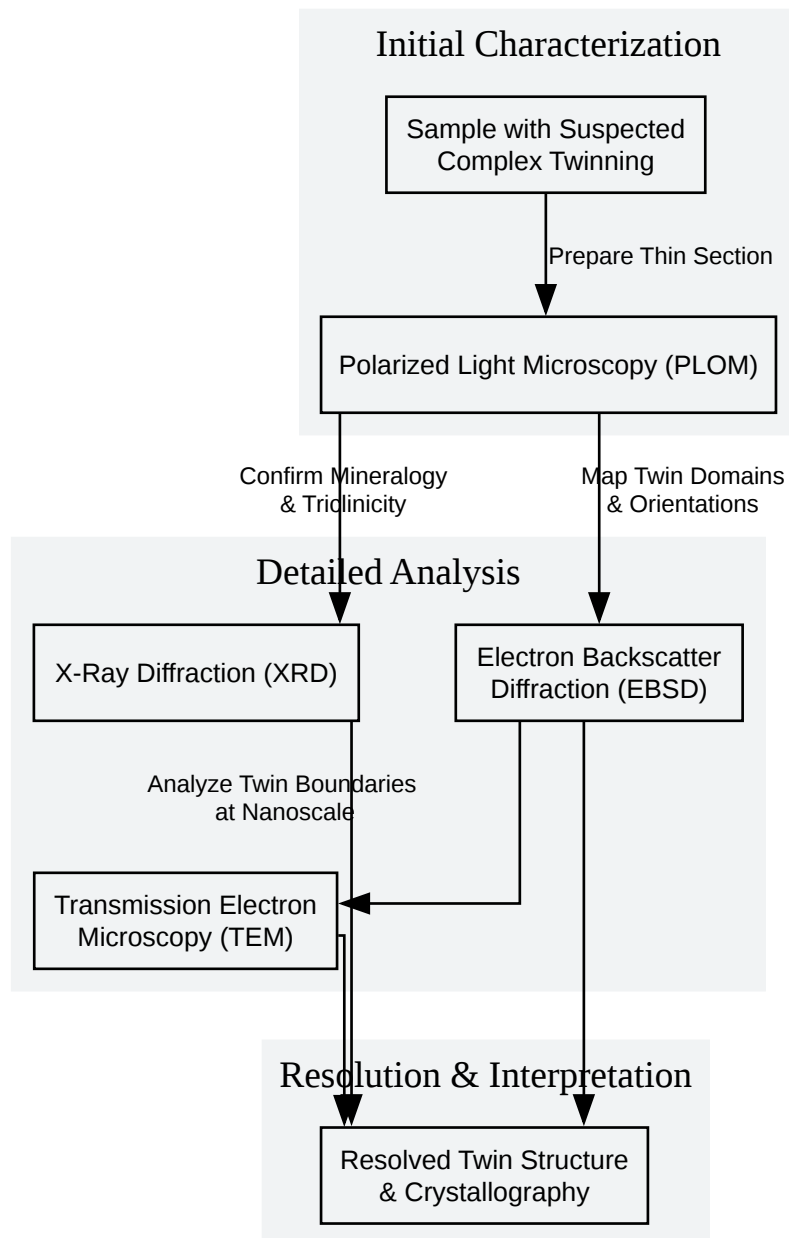

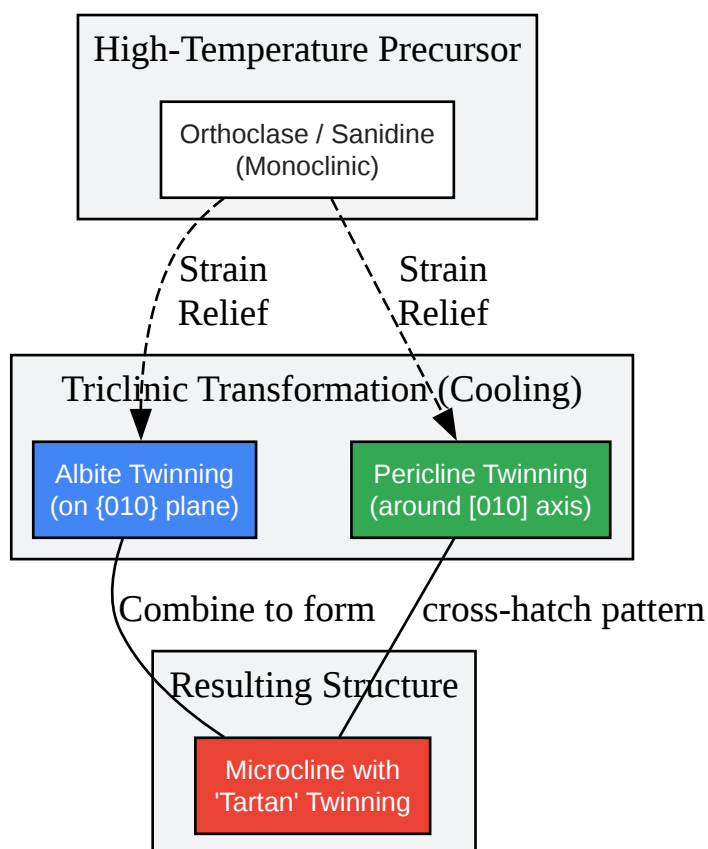

[Click to download full resolution via product page](#)

Need Custom Synthesis?

BenchChem offers custom synthesis for rare earth carbides and specific isotopic labeling.

Email: info@benchchem.com or [Request Quote Online](#).

References

- [1. Twinning, Polymorphism, Polytypism, Pseudomorphism \[www2.tulane.edu\]](http://www2.tulane.edu)
- [2. researchgate.net \[researchgate.net\]](http://researchgate.net)
- [3. s20f9447fef29b6fb.jimcontent.com \[s20f9447fef29b6fb.jimcontent.com\]](http://s20f9447fef29b6fb.jimcontent.com)
- [4. bpb-us-e1.wpmucdn.com \[bpb-us-e1.wpmucdn.com\]](http://bpb-us-e1.wpmucdn.com)
- [5. Microcline - Wikipedia \[en.wikipedia.org\]](http://en.wikipedia.org)
- [6. ruff.net \[ruff.net\]](http://ruff.net)

- [7. msaweb.org \[msaweb.org\]](https://www.msaweb.org)
- [8. researchgate.net \[researchgate.net\]](https://www.researchgate.net)
- [9. Microcline \[science.smith.edu\]](https://science.smith.edu)
- [10. K-feldspar \[sites.und.edu\]](https://sites.und.edu)
- [11. rruff.net \[rruff.net\]](https://www.ruff.net)
- [12. icdd.com \[icdd.com\]](https://www.icdd.com)
- [13. researchgate.net \[researchgate.net\]](https://www.researchgate.net)
- [14. rigaku.com \[rigaku.com\]](https://www.rigaku.com)
- [15. chem.purdue.edu \[chem.purdue.edu\]](https://chem.purdue.edu)
- [16. azonano.com \[azonano.com\]](https://www.azonano.com)
- [17. High-Quality EBSD Sample Preparation | Learn & Share | Leica Microsystems \[leica-microsystems.com\]](https://www.leica-microsystems.com)
- [18. cfamm.ucr.edu \[cfamm.ucr.edu\]](https://cfamm.ucr.edu)
- [19. scispace.com \[scispace.com\]](https://www.scispace.com)
- [20. nanoimages.com \[nanoimages.com\]](https://www.nanoimages.com)
- [21. researchgate.net \[researchgate.net\]](https://www.researchgate.net)
- [22. researchgate.net \[researchgate.net\]](https://www.researchgate.net)
- [23. researchgate.net \[researchgate.net\]](https://www.researchgate.net)
- [24. Thermo Fisher advanced TEM solutions for beam sensitive materials – ScienceOpen \[scienceopen.com\]](https://www.scienceopen.com)
- [25. Analysis of complex, beam-sensitive materials by transmission electron microscopy and associated techniques - PMC \[pmc.ncbi.nlm.nih.gov\]](https://pubmed.ncbi.nlm.nih.gov)
- [26. Analysis of complex, beam-sensitive materials by transmission electron microscopy and associated techniques - PubMed \[pubmed.ncbi.nlm.nih.gov\]](https://pubmed.ncbi.nlm.nih.gov)
- [27. Frontiers | Editorial: Recent advances and challenges in electron microscopy characterizations of radiation-sensitive nanoparticles \[frontiersin.org\]](https://www.frontiersin.org)
- [28. researchgate.net \[researchgate.net\]](https://www.researchgate.net)
- [29. researchgate.net \[researchgate.net\]](https://www.researchgate.net)
- To cite this document: BenchChem. [Technical Support Center: Complex Twinning in Microcline]. BenchChem, [2026]. [Online PDF]. Available at:

[<https://www.benchchem.com/product/b14602288/docs#technical-support-center-complex-twinning-in-microcline>]

Disclaimer & Data Validity:

The information provided in this document is for Research Use Only (RUO) and is strictly not intended for diagnostic or therapeutic procedures. While BenchChem strives to provide accurate protocols, we make no warranties, express or implied, regarding the fitness of this product for every specific experimental setup.

Technical Support: The protocols provided are for reference purposes. Unsure if this reagent suits your experiment?

Need Industrial/Bulk Grade? [Request Custom Synthesis Quote](#)

BenchChem

Our mission is to be the trusted global source of essential and advanced chemicals, empowering scientists and researchers to drive progress in science and industry.

Contact

Address: 3281 E Guasti Rd
Ontario, CA 91761, United States
Phone: (601) 213-4426
Email: info@benchchem.com

[Contact our Ph.D. Support Team for a compatibility check](#)