

Validating Thiourea Formation via TLC Monitoring: A Comparative Technical Guide

Author: BenchChem Technical Support Team. **Date:** May 2026

Compound of Interest

Compound Name: *1,4-Diethoxy-2-isothiocyanatobenzene*

CAS No.: 99855-24-0

Cat. No.: B1460915

[Get Quote](#)

Executive Summary

In drug discovery and organic synthesis, the transformation of isothiocyanates and amines into thioureas is a fundamental ligation strategy. While High-Performance Liquid Chromatography (HPLC) and Nuclear Magnetic Resonance (NMR) offer definitive structural characterization, Thin Layer Chromatography (TLC) remains the most efficient tool for real-time reaction monitoring.

This guide provides a rigorous, self-validating protocol for monitoring thiourea formation. It contrasts TLC's utility against instrumental alternatives and details a specific visualization strategy using UV fluorescence combined with Grote's Reagent to ensure unambiguous confirmation of the thiocarbonyl (

) moiety.

Mechanistic & Chromatographic Basis[1][2]

The Reaction & Polarity Shift

The synthesis typically involves the nucleophilic addition of a primary or secondary amine to an isothiocyanate.

Chemical Equation:

Chromatographic Behavior:

- Isothiocyanates (Starting Material 1): Generally non-polar, exhibiting high Retention Factors ().
- Amines (Starting Material 2): Polar and basic. On standard silica, they often interact strongly with silanol groups, resulting in low values or "streaking."
- Thioureas (Product): Possess intermediate polarity. The formation of the thiourea bridge introduces hydrogen bond donors () and a polar thiocarbonyl group, typically resulting in an value lower than the isothiocyanate but distinct from the amine.

Diagram 1: Reaction Pathway & Polarity Logic

The following diagram illustrates the reaction flow and the corresponding chromatographic shift expected during monitoring.

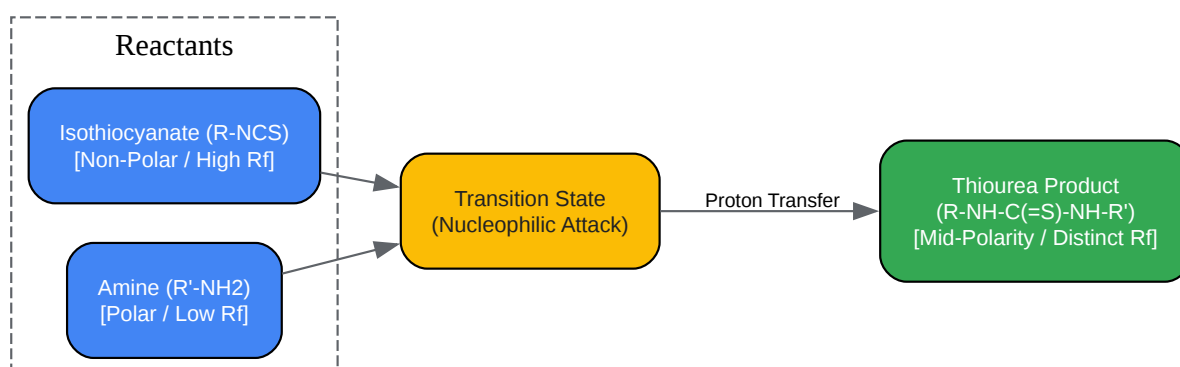

[Click to download full resolution via product page](#)

Figure 1: Mechanistic flow from reactants to product, highlighting the polarity shift critical for TLC separation.

Comparative Analysis: TLC vs. Alternatives

While HPLC is superior for purity assays, TLC is the optimal choice for kinetic monitoring due to throughput and specific staining capabilities.

Table 1: Performance Matrix for Reaction Monitoring

| Feature | TLC (Recommended) | HPLC-MS | 1H NMR |
|-----------------------|--|---|--|
| Primary Utility | Kinetic monitoring; Qualitative ID | Quantitative purity; Mass confirmation | Structural elucidation |
| Throughput | High (Multiple reactions/plate) | Low (Serial injection, 10-30 min/run) | Low (Requires workup/deuterated solvent) |
| Cost Efficiency | <\$1 per run | >\$20 per run (Solvent + Column wear) | High (Instrument time + Solvents) |
| Detection Specificity | High (via Grote's Reagent) | High (via Mass Spec) | High (via Chemical Shift) |
| Limitation | Resolution limits; Co- elution risk | "Ghost peaks" from gradient artifacts | Cannot monitor crude mixtures easily |

Detailed Experimental Protocol

Phase 1: System Selection

- Stationary Phase: Silica Gel 60

(Aluminum or Glass backed). The fluorescence indicator is critical for visualizing the aromatic isothiocyanates.

- Mobile Phase Strategy:
 - Standard Start: Hexane : Ethyl Acetate (3:1).
 - For Polar Thioureas: Dichloromethane (DCM) : Methanol (95:5).
 - Note: If the amine streaks, add 1% Triethylamine () to the mobile phase to neutralize silica acidity.

Phase 2: The "Three-Spot" Validation

Never run a reaction spot in isolation. Use the "Co-spot" technique to detect subtle shifts.

- Lane 1: Starting Isothiocyanate (SM).
- Lane 2: Co-spot (SM + Reaction Mixture).
- Lane 3: Reaction Mixture (RM).

Interpretation: If Lane 2 shows two distinct spots (dumbbell shape) and Lane 3 shows a single new spot, conversion is occurring. If Lane 2 shows a single merged spot, the solvent system is not resolving the product from the reactant; adjust polarity.

Phase 3: Visualization Workflow

Thiourea formation provides a unique chemical handle () for specific staining.

Step A: Non-Destructive UV (254 nm)[1]

- Observe the plate under UV light.[1][2][3][4][5]
- Observation: Isothiocyanates and Thioureas (especially aromatic) will quench fluorescence, appearing as dark spots against a bright green background.
- Action: Circle these spots with a pencil.[1][2][5]

Step B: Specific Staining (Grote's Reagent) Grote's reagent is a specific colorimetric test for thiocarbonyl groups (

) and is superior to Iodine for this application.

- Preparation: Mix 0.5g sodium nitroprusside, 0.5g hydroxylamine HCl, and 1g in 10mL water. Add 2 drops of bromine. Filter and dilute to 25mL [1].
- Application: Dip or spray the plate.[4]
- Result: Thiourea derivatives typically turn blue to purple-red. Isothiocyanates do not typically generate this intense color response immediately or appear distinct.

Diagram 2: Visualization Decision Tree

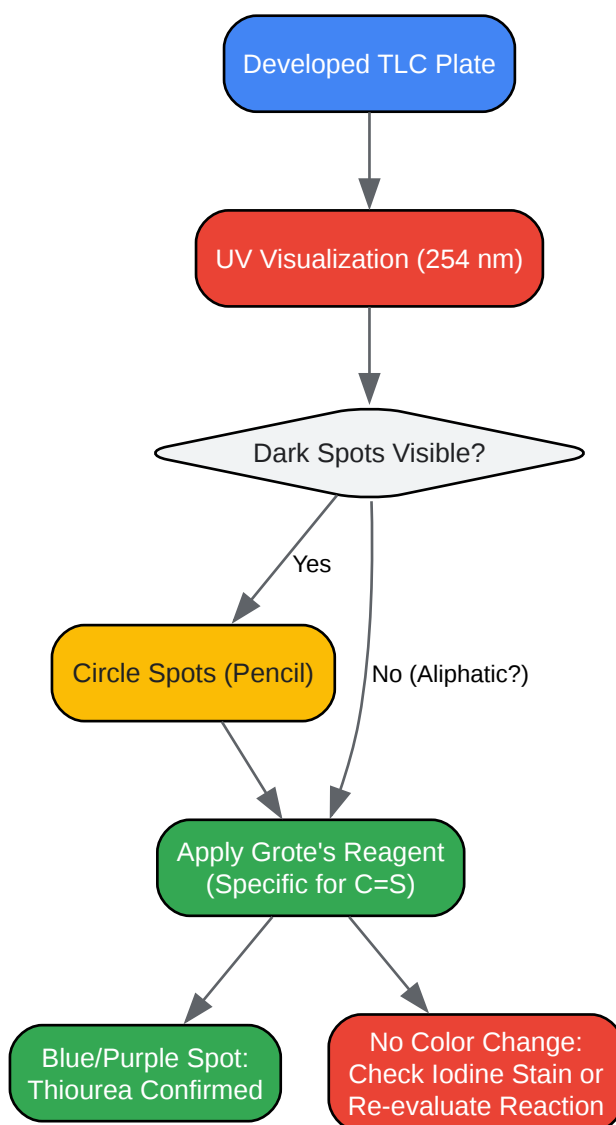

[Click to download full resolution via product page](#)

Figure 2: Step-by-step decision tree for confirming thiourea presence using UV and chemical staining.

Troubleshooting & Expert Insights

The "Ghost" Spot (Decomposition)

Symptom: The product spot smears or shows a tail in 2D TLC. Cause: Thioureas can be unstable on acidic silica, sometimes reverting to isothiocyanates or hydrolyzing to ureas.

Solution: Run a 2D TLC. Spot the reaction mixture in the corner. Run solvent vertically. Dry.

Rotate plate 90° and run again. If the spot appears on the diagonal, the compound is stable. If

off-diagonal spots appear, the compound is decomposing on the silica. Switch to neutral alumina plates or HPLC.

Overlapping Rf Values

Symptom: Product and Isothiocyanate have identical

in Hex/EtOAc. Solution: Switch solvent selectivity. Move to a DCM/MeOH or Toluene/Acetone system. The change in solvation mechanism (dipole-dipole vs. H-bonding) often resolves species that co-elute in simple non-polar systems.

False Negatives with UV

Symptom: Reaction involves aliphatic isothiocyanates (e.g., butyl isothiocyanate) and aliphatic amines. No UV activity. Solution: Skip UV. Rely entirely on Iodine (

) chamber (turns brown) or Grote's Reagent (turns blue/purple). Aliphatic thioureas are invisible to 254 nm UV unless a chromophore is present.

References

- ResearchGate.How can I check for the presence of a "NCS (isothiocyanates)" group on TLC? (Discussion on Grote's Reagent preparation and utility). [[Link](#)]
- Chemistry LibreTexts.TLC Visualization Methods. (Comprehensive guide on UV and chemical staining mechanisms).[1] [[Link](#)]
- Triclinic Labs.Analytical Chromatographic Separation Services (TLC, HPLC, GC).[6] (Comparison of TLC and HPLC for industrial applications). [[Link](#)]
- Royal Society of Chemistry (RSC).Selective oxidation of thiourea with H₂O₂ catalyzed by [RuIII(edta)(H₂O)]⁻.[7] (Mechanistic studies involving thiourea detection). [[Link](#)]

Need Custom Synthesis?

BenchChem offers custom synthesis for rare earth carbides and specific isotopic labeling.

Email: info@benchchem.com or [Request Quote Online](#).

Sources

- [1. chem.libretexts.org](https://chem.libretexts.org) [chem.libretexts.org]
- [2. people.chem.umass.edu](https://people.chem.umass.edu) [people.chem.umass.edu]
- [3. theory.labster.com](https://theory.labster.com) [theory.labster.com]
- [4. epfl.ch](https://epfl.ch) [epfl.ch]
- [5. faculty.fiu.edu](https://faculty.fiu.edu) [faculty.fiu.edu]
- [6. Separations Analysis \(TLC, HPLC, GC\) Services](https://triclincilabs.com) [triclincilabs.com]
- [7. Selective oxidation of thiourea with H₂O₂ catalyzed by \[RuIII\(edta\)\(H₂O\)\]⁻: kinetic and mechanistic studies - Dalton Transactions \(RSC Publishing\)](https://pubs.rsc.org) [pubs.rsc.org]
- To cite this document: BenchChem. [Validating Thiourea Formation via TLC Monitoring: A Comparative Technical Guide]. BenchChem, [2026]. [Online PDF]. Available at: [<https://www.benchchem.com/product/b1460915/docs#validating-thiourea-formation-via-tlc-monitoring-a-comparative-technical-guide>]

Disclaimer & Data Validity:

The information provided in this document is for Research Use Only (RUO) and is strictly not intended for diagnostic or therapeutic procedures. While BenchChem strives to provide accurate protocols, we make no warranties, express or implied, regarding the fitness of this product for every specific experimental setup.

Technical Support: The protocols provided are for reference purposes. Unsure if this reagent suits your experiment?

Need Industrial/Bulk Grade? [Request Custom Synthesis Quote](#)

BenchChem

Our mission is to be the trusted global source of essential and advanced chemicals, empowering scientists and researchers to drive progress in science and industry.

Contact

Address: 3281 E Guasti Rd

Ontario, CA 91761, United States

Phone: (601) 213-4426

Email: info@benchchem.com

[Contact our Ph.D. Support Team for a compatibility check](#)