

# Technical Support Center: Polyvinyl Acetate Synthesis

**Author:** BenchChem Technical Support Team. **Date:** April 2026

## Compound of Interest

Compound Name: Vinyl acetate

CAS No.: 9003-20-7

Cat. No.: B146075

[Get Quote](#)

This technical support center provides troubleshooting guidance and frequently asked questions (FAQs) for researchers, scientists, and drug development professionals working on the synthesis of poly**vinyl acetate** (PVAc). The focus of this guide is to address common challenges, with a particular emphasis on minimizing polymer branching.

## Troubleshooting Guide

This section addresses specific issues that may arise during poly**vinyl acetate** synthesis, offering potential causes and solutions.

Problem	Potential Cause	Recommended Solution
<p>High Polydispersity Index (PDI &gt; 2.0) in Free Radical Polymerization</p>	<p>Uncontrolled termination and chain transfer reactions are inherent to conventional free-radical polymerization.</p>	<p>- Optimize Initiator Concentration: A higher initiator concentration can lead to a higher rate of initiation and the formation of shorter polymer chains, which can sometimes help in reducing the PDI. However, an excessively high concentration can also lead to more termination events. Systematic optimization is key.[1][2] - Implement Controlled Radical Polymerization (CRP): Techniques like RAFT or ATRP provide better control over the polymerization process, leading to polymers with a narrow molecular weight distribution (PDI &lt; 1.5).[3]</p>
<p>Significant Polymer Branching</p>	<p>Chain transfer to the polymer is a common side reaction in vinyl acetate polymerization, where a growing radical abstracts a hydrogen atom from an existing polymer chain, creating a new radical site on the backbone, which then initiates the growth of a branch.[4] This is more prevalent at higher monomer conversions.</p>	<p>- Limit Monomer Conversion: Terminate the reaction at a lower monomer conversion to reduce the probability of chain transfer to the polymer.[4] - Use a Chain Transfer Agent (CTA): A CTA can help regulate the molecular weight and reduce branching by terminating growing chains and initiating new ones.[5] - Employ Controlled Radical Polymerization (CRP): CRP techniques, such as RAFT, are effective in minimizing</p>

branching by controlling the growth of polymer chains.[\[6\]](#)[\[7\]](#)

Runaway Reaction/Poor Thermal Control

Vinyl acetate polymerization is highly exothermic. In bulk or solution polymerization, poor heat dissipation can lead to an uncontrolled increase in temperature and reaction rate, a phenomenon known as the gel effect.[\[8\]](#)[\[9\]](#)

- Ensure Adequate Heat Removal: Use a reaction setup with efficient heat transfer, such as a well-stirred reactor with a cooling jacket. - Use a Semi-Batch or Continuous Process: Adding the monomer gradually (semi-batch) can help to control the reaction rate and temperature.[\[10\]](#) - Perform Polymerization in Emulsion or Suspension: These methods use a continuous phase (typically water) that acts as an efficient heat sink, providing better temperature control.[\[10\]](#)  
[\[11\]](#)

Low Polymer Yield

- Insufficient Initiator: The amount of initiator may not be enough to achieve the desired conversion. - Presence of Inhibitors: Residual inhibitors in the monomer can quench radicals and prevent polymerization. - Low Reaction Temperature: The temperature may be too low for the initiator to decompose at an effective rate.

- Increase Initiator Concentration: Incrementally increase the amount of initiator. - Purify the Monomer: Ensure the vinyl acetate monomer is free of inhibitors before use. - Increase Reaction Temperature: Raise the temperature to the optimal range for your chosen initiator (e.g., ~60-80°C for AIBN or benzoyl peroxide).[\[9\]](#)

Inconsistent Results in Emulsion Polymerization

Emulsion polymerizations are complex systems sensitive to variations in agitation speed, surfactant concentration, and the rate of monomer addition.

- Maintain Consistent Agitation: Use a calibrated overhead stirrer to ensure reproducible mixing. - Control Monomer Feed Rate: In semi-batch

These factors can affect particle nucleation and growth, leading to batch-to-batch variability.

processes, a consistent and controlled monomer feed rate is crucial for uniform particle growth.[12] - Optimize Surfactant/Protective Colloid Concentration: The type and concentration of stabilizer are critical for particle stability and size control.[11][13]

---

## Frequently Asked Questions (FAQs)

Q1: What is the primary mechanism of branching in polyvinyl acetate synthesis?

A1: The primary mechanism for branching in the free-radical polymerization of vinyl acetate is chain transfer to the polymer.[4] In this process, a growing polymer radical abstracts a hydrogen atom from the backbone or the acetate group of a "dead" (fully formed) polymer chain. This creates a new radical site on the previously inactive polymer, from which a new polymer chain (a branch) can grow. This is more likely to occur at higher monomer conversions when the concentration of polymer is high.[4]

Q2: How can I quantify the degree of branching in my PVAc sample?

A2: Nuclear Magnetic Resonance (NMR) spectroscopy, specifically <sup>13</sup>C NMR, is a powerful technique for quantifying branching in PVAc.[4] By analyzing the integrals of specific peaks in the spectrum that correspond to the carbons at the branch points, you can determine the mole percent of branched units in your polymer.[4] Size Exclusion Chromatography coupled with a multi-angle light scattering detector (SEC-MALS) can also be used to determine the branching ratio by comparing the radius of gyration of the branched polymer to that of a linear equivalent of the same molecular weight.

Q3: What are the main differences between conventional free-radical polymerization and controlled radical polymerization (CRP) for PVAc synthesis?

A3:

- **Control over Polymerization:** In conventional free-radical polymerization, initiation, propagation, and termination occur continuously and uncontrollably, leading to a broad distribution of polymer chain lengths and a higher degree of branching.[14] CRP techniques, such as Atom Transfer Radical Polymerization (ATRP) and Reversible Addition-Fragmentation chain Transfer (RAFT) polymerization, introduce a dynamic equilibrium between active propagating radicals and dormant species.[15] This allows for the simultaneous growth of all polymer chains, providing excellent control over molecular weight, a narrow molecular weight distribution (low PDI), and minimized branching.[3][15]
- **Polymer Architecture:** CRP allows for the synthesis of well-defined polymer architectures, such as block copolymers, which is challenging with conventional free-radical methods.[16]

Q4: What is the role of an initiator and how does its concentration affect the final polymer?

A4: An initiator is a thermally or photochemically unstable compound that decomposes to form free radicals, which in turn initiate the polymerization of monomer units.[14] Common initiators for **vinyl acetate** polymerization include azobisisobutyronitrile (AIBN) and benzoyl peroxide. The concentration of the initiator has a significant impact on the final polymer:

- **Higher Initiator Concentration:** Generally leads to a higher polymerization rate and lower average molecular weight, as more polymer chains are initiated simultaneously.[2][17]
- **Lower Initiator Concentration:** Results in a slower polymerization rate and higher average molecular weight.[17]

Q5: How does temperature influence the synthesis of PVAc?

A5: Temperature is a critical parameter in PVAc synthesis:

- **Rate of Polymerization:** Higher temperatures increase the rate of initiator decomposition and the rate of propagation, leading to a faster overall polymerization rate.[9]
- **Branching:** Increased temperature can also increase the rate of chain transfer to the polymer, potentially leading to a higher degree of branching.[4]
- **Molecular Weight:** Generally, higher temperatures result in lower molecular weight polymers due to the increased rate of initiation and termination reactions.

## Experimental Protocols

### Protocol 1: Conventional Free-Radical Solution

### Polymerization of Vinyl Acetate

This protocol describes a standard laboratory-scale free-radical polymerization of **vinyl acetate** in a solvent.

Materials:

- **Vinyl acetate** (inhibitor removed)
- Azobisisobutyronitrile (AIBN)
- Toluene (or another suitable solvent)
- Methanol (for precipitation)
- Round-bottom flask with a reflux condenser and magnetic stirrer
- Nitrogen or Argon inlet
- Heating mantle with temperature control

Procedure:

- **Monomer Purification:** Pass **vinyl acetate** through a column of activated alumina to remove the inhibitor (hydroquinone).
- **Reaction Setup:** Assemble a round-bottom flask with a reflux condenser and a magnetic stir bar. The setup should have an inlet for an inert gas.
- **Deoxygenation:** Add **vinyl acetate** and toluene to the flask. Bubble nitrogen or argon through the solution for 20-30 minutes to remove dissolved oxygen, which can inhibit the polymerization.
- **Initiator Addition:** Dissolve the desired amount of AIBN in the monomer/solvent mixture.

- **Polymerization:** Heat the reaction mixture to 60-70°C with constant stirring under a positive pressure of inert gas. The reaction time will depend on the desired conversion but is typically several hours.
- **Termination and Precipitation:** Cool the reaction mixture to room temperature. Pour the viscous solution into a large excess of cold methanol with vigorous stirring to precipitate the **polyvinyl acetate**.
- **Purification:** Filter the precipitated polymer and wash it with fresh methanol to remove any unreacted monomer and initiator fragments.
- **Drying:** Dry the polymer in a vacuum oven at a low temperature (e.g., 40°C) until a constant weight is achieved.

## Protocol 2: RAFT Polymerization of Vinyl Acetate

This protocol provides a method for the controlled polymerization of **vinyl acetate** using the RAFT technique to achieve a polymer with low polydispersity and minimal branching.

Materials:

- **Vinyl acetate** (inhibitor removed)
- AIBN (initiator)
- RAFT agent (e.g., a xanthate or dithiobenzoate suitable for **vinyl acetate**)
- Ampule or Schlenk tube
- Vacuum line
- Oil bath

Procedure:

- **Preparation of Reaction Mixture:** In an ampule or Schlenk tube, combine the purified **vinyl acetate**, AIBN, and the RAFT agent in the desired molar ratios.[\[18\]](#)

- Degassing: Subject the contents of the ampule to at least three freeze-pump-thaw cycles to thoroughly remove all dissolved oxygen.[18]
- Sealing: Seal the ampule under vacuum.[18]
- Polymerization: Place the sealed ampule in a preheated oil bath at the desired temperature (typically 60°C for AIBN). Allow the polymerization to proceed for the planned duration to reach the target conversion.
- Isolation: After the specified time, remove the ampule from the oil bath and cool it to terminate the polymerization. Open the ampule and dissolve the contents in a suitable solvent (e.g., THF).
- Purification: Precipitate the polymer by adding the solution to a non-solvent like hexane or methanol. Filter and dry the polymer under vacuum.

## Data Presentation

### Table 1: Effect of Initiator to Monomer Ratio on PVAc Molecular Weight and Conversion (Solution Polymerization)

Initiator/Monomer (I/M) Ratio (by weight)	Monomer/Solvent (M/S) Ratio (by weight)	Reaction Time (min)	Conversion (%)	Viscosity-Average Molecular Weight (Mv)
0.0025	70/30	180	75.8	105,000
0.010	70/30	180	85.2	65,000
0.050	70/30	180	92.5	32,000

Data adapted from a study on the effect of initiator-monomer ratio in the polymerization of vinyl acetate.[17]

## Table 2: Comparison of Branching in Bulk vs. Emulsion Polymerization of Vinyl Acetate

Polymerization Method	Final Conversion (%)	Mole Percent Branches
Bulk Polymerization	~20	0.13 - 0.23
Emulsion Polymerization	>95	0.61 - 0.75

Data from a <sup>13</sup>C NMR study on chain transfer to polymer in free-radical polymerization of vinyl acetate.[4] This table illustrates that the higher instantaneous conversion within the polymer particles in emulsion polymerization leads to a significantly higher level of branching.

# Visualizations

## Free-Radical Polymerization and Branching Pathway

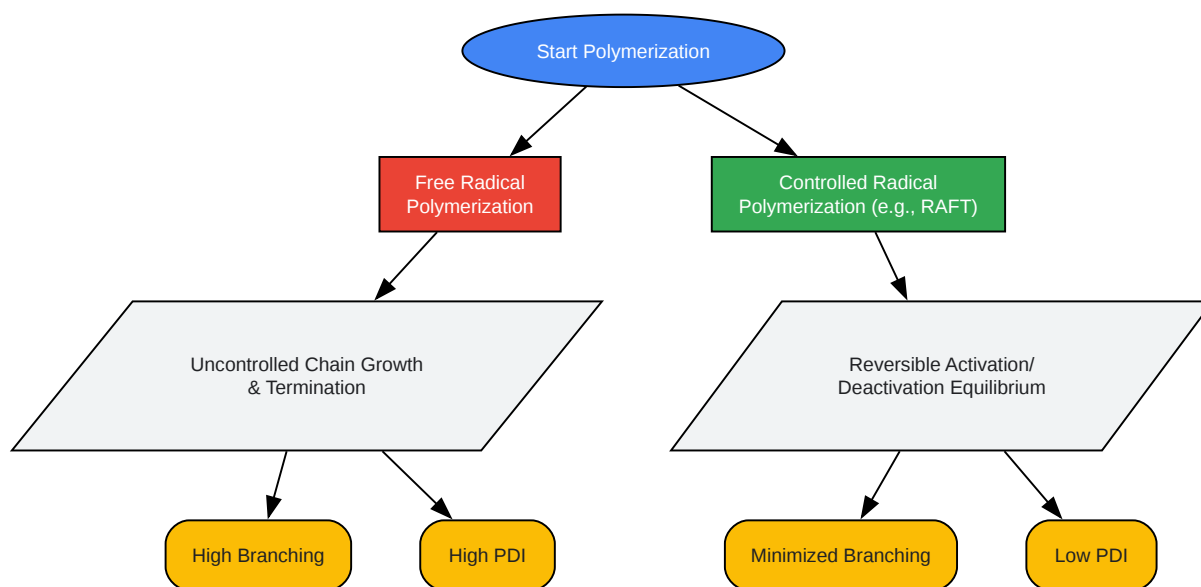
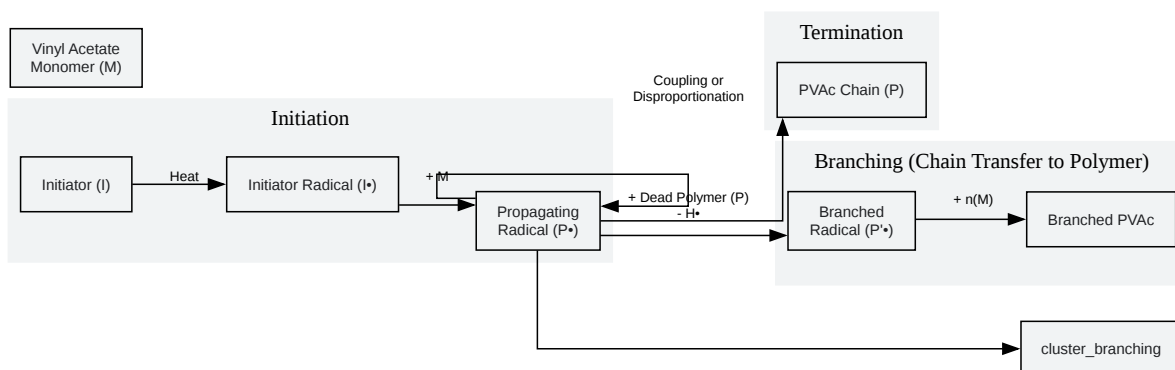

[Click to download full resolution via product page](#)

### Need Custom Synthesis?

BenchChem offers custom synthesis for rare earth carbides and specific isotopic labeling.

Email: [info@benchchem.com](mailto:info@benchchem.com) or [Request Quote Online](#).

## References

- 1. The Influence of Initiator Concentration on Selected Properties on Poly-N-Vinylcaprolactam Nanoparticles - PMC [[pmc.ncbi.nlm.nih.gov](https://pubmed.ncbi.nlm.nih.gov)]
- 2. [researchgate.net](https://researchgate.net) [[researchgate.net](https://researchgate.net)]
- 3. [pubs.acs.org](https://pubs.acs.org) [[pubs.acs.org](https://pubs.acs.org)]
- 4. [pubs.acs.org](https://pubs.acs.org) [[pubs.acs.org](https://pubs.acs.org)]
- 5. [researchgate.net](https://researchgate.net) [[researchgate.net](https://researchgate.net)]
- 6. [research.manchester.ac.uk](https://research.manchester.ac.uk) [[research.manchester.ac.uk](https://research.manchester.ac.uk)]
- 7. [researchgate.net](https://researchgate.net) [[researchgate.net](https://researchgate.net)]
- 8. [icheme.org](https://icheme.org) [[icheme.org](https://icheme.org)]
- 9. [researchgate.net](https://researchgate.net) [[researchgate.net](https://researchgate.net)]
- 10. Emulsion polymerization of vinyl acetate: safe optimization of a hazardous complex process - PubMed [[pubmed.ncbi.nlm.nih.gov](https://pubmed.ncbi.nlm.nih.gov)]
- 11. [diva-portal.org](https://diva-portal.org) [[diva-portal.org](https://diva-portal.org)]
- 12. [mdpi.com](https://mdpi.com) [[mdpi.com](https://mdpi.com)]
- 13. How to Minimize Settling in Polyvinyl Acetate Dispersions? [[eureka.patsnap.com](https://eureka.patsnap.com)]
- 14. [pslc.ws](https://pslc.ws) [[pslc.ws](https://pslc.ws)]
- 15. [researchgate.net](https://researchgate.net) [[researchgate.net](https://researchgate.net)]
- 16. Synthesis of poly(vinyl acetate) block copolymers by successive RAFT and ATRP with a bromoxanthate iniferter - Chemical Communications (RSC Publishing) [[pubs.rsc.org](https://pubs.rsc.org)]
- 17. [bipublication.com](https://bipublication.com) [[bipublication.com](https://bipublication.com)]
- 18. RAFT Polymerization Procedures [[sigmaaldrich.com](https://sigmaaldrich.com)]
- To cite this document: BenchChem. [Technical Support Center: Polyvinyl Acetate Synthesis]. BenchChem, [2026]. [Online PDF]. Available at:

[\[https://www.benchchem.com/product/b146075/docs#technical-support-center-polyvinyl-acetate-synthesis\]](https://www.benchchem.com/product/b146075/docs#technical-support-center-polyvinyl-acetate-synthesis)

### Disclaimer & Data Validity:

The information provided in this document is for Research Use Only (RUO) and is strictly not intended for diagnostic or therapeutic procedures. While BenchChem strives to provide accurate protocols, we make no warranties, express or implied, regarding the fitness of this product for every specific experimental setup.

**Technical Support:** The protocols provided are for reference purposes. Unsure if this reagent suits your experiment?

**Need Industrial/Bulk Grade?** [Request Custom Synthesis Quote](#)

## BenchChem

Our mission is to be the trusted global source of essential and advanced chemicals, empowering scientists and researchers to drive progress in science and industry.

### Contact

Address: 3281 E Guasti Rd  
Ontario, CA 91761, United States  
Phone: (601) 213-4426  
Email: [info@benchchem.com](mailto:info@benchchem.com)

[Contact our Ph.D. Support Team for a compatibility check](#)