

Core Concepts: The Electrophilic Nature of the Isocyanate Group

Author: BenchChem Technical Support Team. **Date:** December 2025

Compound of Interest

Compound Name: Cyclohexyl isocyanate

Cat. No.: B146478

[Get Quote](#)

The isocyanate functional group ($-N=C=O$) is a cornerstone of addition chemistry, renowned for its potent electrophilic character. This reactivity is fundamental to its widespread use in the synthesis of polyurethanes, pharmaceuticals, and agrochemicals. The electrophilicity of an isocyanate is dictated by the unique electronic structure of the cumulene system, where a central carbon atom is double-bonded to two highly electronegative atoms: nitrogen and oxygen.

Electronic Structure and Resonance

The high electrophilicity of the isocyanate's central carbon is a direct result of bond polarization. The electronegative oxygen and nitrogen atoms withdraw electron density, inducing a significant partial positive charge ($\delta+$) on the carbon. This electronic state is best described by its principal resonance contributors, which highlight the electron-deficient nature of the carbon, making it a prime target for nucleophilic attack.

From a molecular orbital (MO) perspective, the Lowest Unoccupied Molecular Orbital (LUMO) of the isocyanate group is predominantly localized on the central carbon atom. This low-energy, accessible orbital readily accepts electron density from an incoming nucleophile, facilitating a rapid reaction.

Cyclohexyl Isocyanate: An Aliphatic Electrophile

Cyclohexyl isocyanate ($C_6H_{11}NCO$) is an aliphatic isocyanate. Unlike aromatic isocyanates where the NCO group is attached to an aryl ring, the cyclohexyl group is a saturated alkyl

substituent. This structural difference has significant implications for its reactivity:

- **Electronic Effects:** The cyclohexyl group is weakly electron-donating through induction (+I effect), which slightly reduces the partial positive charge on the isocyanate carbon compared to aromatic isocyanates that feature electron-withdrawing aryl groups. Consequently, aliphatic isocyanates like **cyclohexyl isocyanate** are generally less reactive than their aromatic counterparts (e.g., phenyl isocyanate).
- **Steric Effects:** The bulky, non-planar cyclohexane ring presents a greater steric hindrance to the approach of a nucleophile compared to a less bulky alkyl group (e.g., methyl isocyanate). This steric factor can significantly influence the rate of reaction, particularly with larger nucleophiles.

Reactivity and Reaction Mechanisms

Isocyanates are highly versatile electrophiles that react with a wide array of nucleophiles, particularly compounds containing active hydrogen atoms.[1] The general mechanism involves the nucleophilic attack on the electron-deficient isocyanate carbon, followed by proton transfer to the nitrogen atom.

Key reactions involving **cyclohexyl isocyanate** include:

- **Reaction with Alcohols:** Forms a urethane (carbamate) linkage. This is the foundational reaction for polyurethane synthesis.[1]
- **Reaction with Amines:** Forms a urea derivative. This reaction is typically much faster than the reaction with alcohols.[2]
- **Reaction with Water:** Initially forms an unstable carbamic acid, which then decomposes to yield a primary amine (cyclohexylamine) and carbon dioxide gas.[1] The newly formed amine can then react with another molecule of **cyclohexyl isocyanate** to form a disubstituted urea.
- **Reaction with Thiols:** In the presence of a base catalyst, thiols react to form thiocarbamates. [3]

Quantitative Analysis of Cyclohexyl Isocyanate

Reactivity

The reactivity of **cyclohexyl isocyanate** can be quantified through kinetic and thermodynamic measurements. While extensive kinetic data for this specific isocyanate is less common than for industrial diisocyanates, the following table summarizes available data from the literature. The reactions generally follow second-order kinetics.^{[4][5]}

Parameter	Reactant	Catalyst	Solvent	Conditions	Value	Reference
Second-Order Rate Constant (k_2)	Butan-1-ol	None	CCl_4	50 °C	2.08×10^{-5} $\text{L mol}^{-1} \text{s}^{-1}$	[4]
Second-Order Rate Constant (k_2)	Butan-1-ol	None (Light-assisted)	CCl_4	50 °C	5.42×10^{-3} $\text{L mol}^{-1} \text{s}^{-1}$	[4]
Second-Order Rate Constant (k_2)	Butan-1-ol	Ferrocene	CCl_4	50 °C	6.37×10^{-5} $\text{L mol}^{-1} \text{s}^{-1}$	[4]
Second-Order Rate Constant (k_2)	Butan-1-ol	Ferrocene (Light-assisted)	CCl_4	50 °C	0.219 L $\text{mol}^{-1} \text{s}^{-1}$	[4]
Estimated Rate Constant (k)	Hydroxyl Radical	None (Vapor Phase)	N/A	25 °C	1.0×10^{-11} cm^3 molecule^{-1} s^{-1}	[6]
Standard Enthalpy of Reaction ($\Delta_r H^\circ$)	Aniline	None	Dioxane	Liquid Phase	-98.4 ± 1.1 kJ/mol	

Visualized Workflows and Mechanisms

General Nucleophilic Addition Pathway

The fundamental reaction pathway for an isocyanate involves the attack of a nucleophile (containing an active hydrogen, H-Nu) on the electrophilic carbon of the isocyanate group.

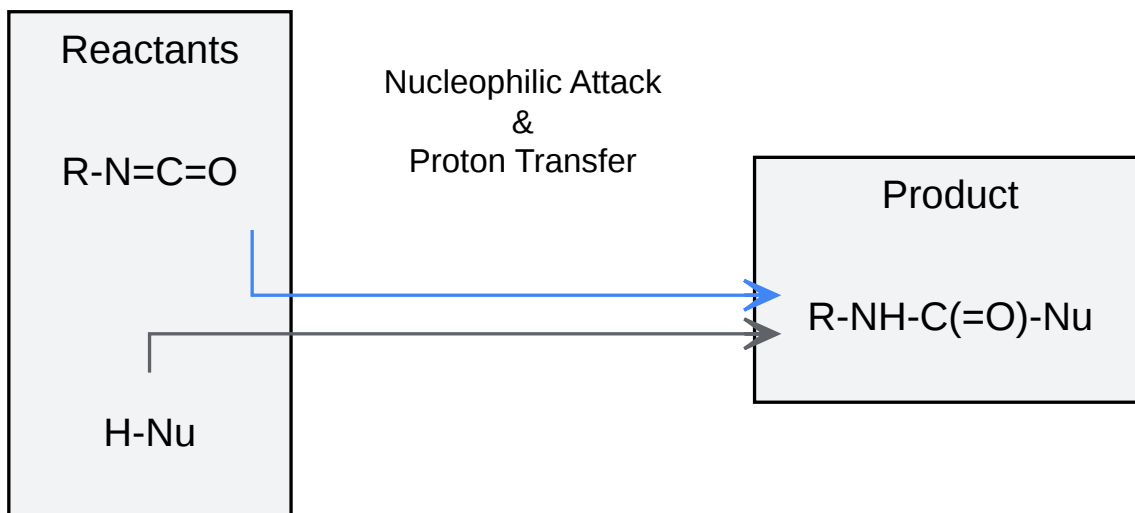

[Click to download full resolution via product page](#)

Caption: General reaction mechanism of an isocyanate with a nucleophile.

Logical Workflow for Kinetic Analysis via In-Situ FTIR

In-situ Fourier Transform Infrared (FTIR) spectroscopy is a powerful technique for real-time monitoring of isocyanate reactions by tracking the disappearance of the characteristic $N=C=O$ stretching vibration.

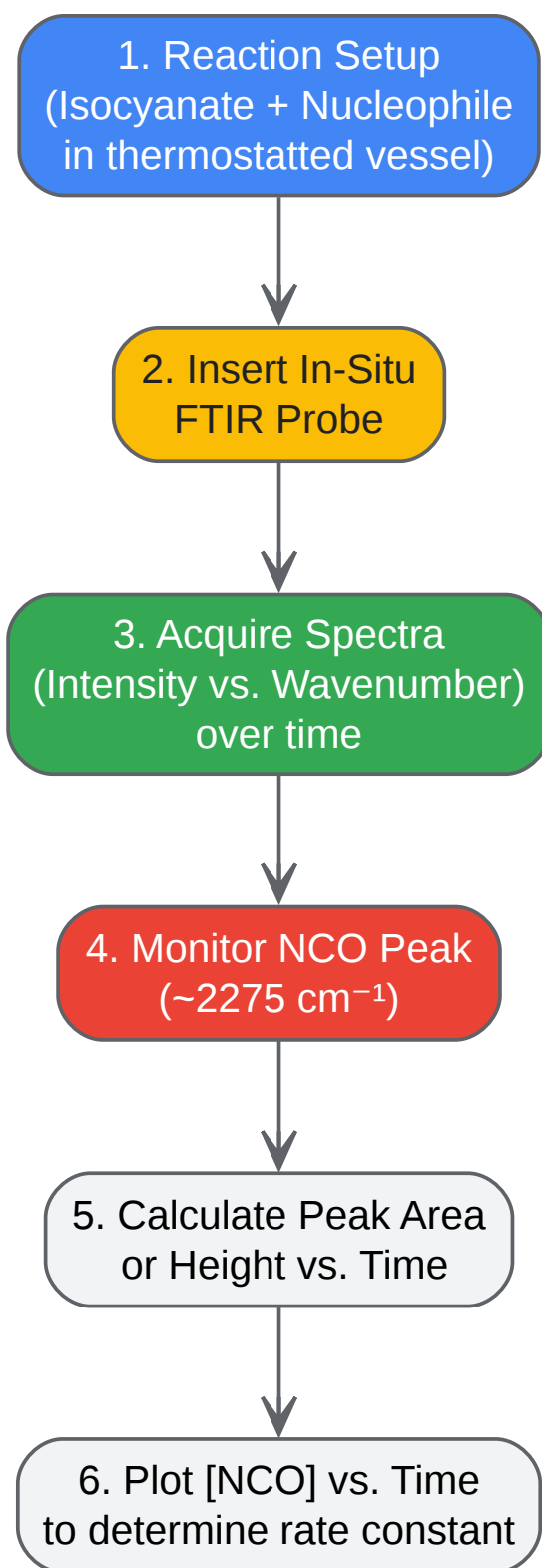

[Click to download full resolution via product page](#)

Caption: Experimental workflow for monitoring isocyanate reaction kinetics using FTIR.

Experimental Workflow for NCO Content Determination

The determination of the isocyanate content (%NCO) is a critical quality control measure, often performed by back-titration.

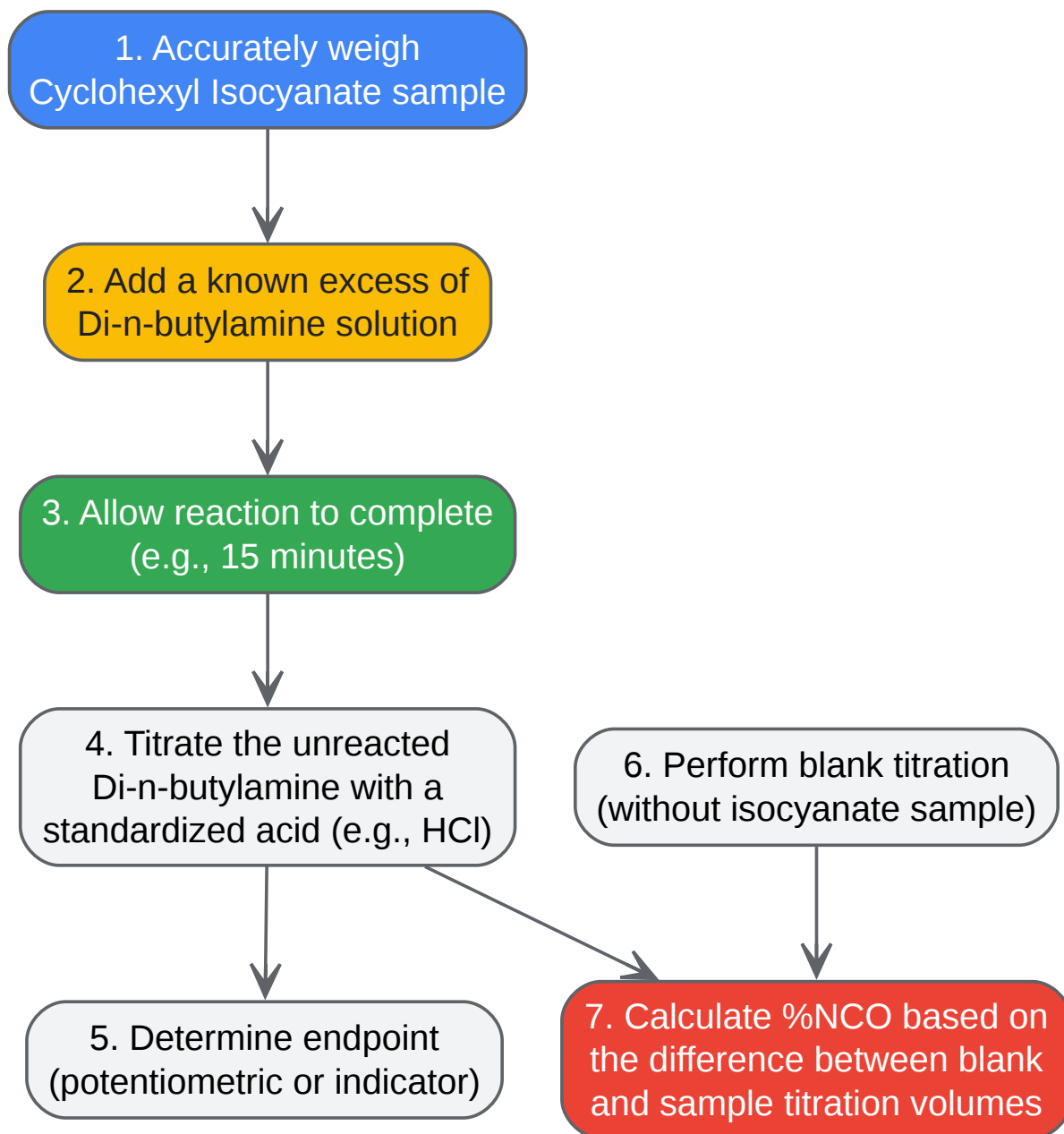

[Click to download full resolution via product page](#)

Caption: Workflow for determining isocyanate content via back-titration.

Key Experimental Protocols

Protocol for In-Situ FTIR Kinetic Monitoring

This protocol describes the real-time monitoring of the reaction between **cyclohexyl isocyanate** and an alcohol (e.g., 1-butanol).

- **System Setup:** A jacketed glass reactor is equipped with a mechanical stirrer, a temperature probe, and an inlet for inert gas (e.g., nitrogen). The reactor temperature is maintained using a circulating bath.
- **FTIR Probe:** An Attenuated Total Reflectance (ATR) FTIR probe is inserted directly into the reaction vessel. A background spectrum of the solvent is collected.
- **Reagent Preparation:** Prepare stock solutions of **cyclohexyl isocyanate** and the chosen alcohol in a dry, inert solvent (e.g., anhydrous toluene or carbon tetrachloride).
- **Reaction Initiation:** Charge the reactor with the alcohol solution and allow it to reach thermal equilibrium. Initiate the reaction by adding the **cyclohexyl isocyanate** solution.
- **Data Acquisition:** Immediately begin collecting mid-IR spectra at regular intervals (e.g., every 60 seconds).
- **Data Analysis:** The concentration of the isocyanate group is monitored by measuring the area or height of its characteristic sharp absorption peak between 2250 and 2285 cm^{-1} . The disappearance of this peak over time is used to calculate the reaction rate. A plot of $1/[\text{NCO}]$ versus time for a second-order reaction will yield a straight line whose slope is the rate constant, k .

Protocol for NCO Content Determination via Titration

This method determines the weight percentage of NCO groups in a sample of **cyclohexyl isocyanate**.

- **Reagent Preparation:**
 - **Titrant:** Standardized 0.5 M hydrochloric acid (HCl) in a suitable solvent (e.g., isopropanol).

- Reaction Solution: A solution of di-n-butylamine in dry toluene (e.g., 130 g per liter).
- Sample Preparation: Accurately weigh approximately 2 g of the **cyclohexyl isocyanate** sample into a 250 mL Erlenmeyer flask.
- Reaction: Using a volumetric pipette, add exactly 25.00 mL of the di-n-butylamine-toluene solution to the flask. Add a magnetic stir bar, stopper the flask, and stir gently for 15 minutes at room temperature to ensure complete reaction between the isocyanate and the amine.
- Titration: Add 150 mL of a solvent like 2-propanol to the flask. Immerse a pH electrode (for potentiometric titration) and titrate the solution with the standardized 0.5 M HCl solution.
- Blank Determination: Repeat steps 3 and 4 without adding the **cyclohexyl isocyanate** sample. This determines the initial amount of di-n-butylamine.
- Calculation: The NCO content is calculated using the following formula: $\%NCO = [(V_{\text{blank}} - V_{\text{sample}}) * N_{\text{acid}} * 4.202] / W_{\text{sample}}$ Where:
 - V_{blank} = Volume of HCl used for the blank (mL)
 - V_{sample} = Volume of HCl used for the sample (mL)
 - N_{acid} = Normality of the HCl titrant (mol/L)
 - 4.202 = A constant combining the molecular weight of the NCO group (42.02 g/mol) and a conversion factor.
 - W_{sample} = Weight of the sample (g)

Conclusion

Cyclohexyl isocyanate serves as a quintessential example of an aliphatic isocyanate, whose electrophilicity is moderated by the electronic and steric properties of the cyclohexyl group. Its reactivity towards nucleophiles, particularly alcohols and amines, is central to its application in polymer and synthetic chemistry. A thorough understanding of its electrophilic nature, quantified by kinetic data and characterized through established analytical protocols like FTIR spectroscopy and titrimetric analysis, is crucial for researchers and developers in optimizing reaction conditions, ensuring product quality, and designing novel materials and molecules.

Need Custom Synthesis?

BenchChem offers custom synthesis for rare earth carbides and specific isotopic labeling.

Email: info@benchchem.com or [Request Quote Online](#).

References

- 1. Isocyanate - Wikipedia [en.wikipedia.org]
- 2. poliuretanos.net [poliuretanos.net]
- 3. researchgate.net [researchgate.net]
- 4. Photoassisted reaction between alcohols and isocyanates - Journal of the Chemical Society, Chemical Communications (RSC Publishing) [pubs.rsc.org]
- 5. Kinetic studies of the reactions between isocyanates and carboxylic acids | Semantic Scholar [semanticscholar.org]
- 6. Cyclohexyl isocyanate | C7H11NO | CID 18502 - PubChem [pubchem.ncbi.nlm.nih.gov]
- To cite this document: BenchChem. [Core Concepts: The Electrophilic Nature of the Isocyanate Group]. BenchChem, [2025]. [Online PDF]. Available at: [https://www.benchchem.com/product/b146478#understanding-the-electrophilicity-of-cyclohexyl-isocyanate]

Disclaimer & Data Validity:

The information provided in this document is for Research Use Only (RUO) and is strictly not intended for diagnostic or therapeutic procedures. While BenchChem strives to provide accurate protocols, we make no warranties, express or implied, regarding the fitness of this product for every specific experimental setup.

Technical Support: The protocols provided are for reference purposes. Unsure if this reagent suits your experiment? [[Contact our Ph.D. Support Team for a compatibility check](#)]

Need Industrial/Bulk Grade? [Request Custom Synthesis Quote](#)

BenchChem

Our mission is to be the trusted global source of essential and advanced chemicals, empowering scientists and researchers to drive progress in science and industry.

Contact

Address: 3281 E Guasti Rd

Ontario, CA 91761, United States

Phone: (601) 213-4426

Email: info@benchchem.com