

# Precision Profiling: MS/MS Fragmentation Guide for Atorvastatin Precursors

**Author:** BenchChem Technical Support Team. **Date:** April 2026

## Compound of Interest

**Compound Name:** (S)-tert-Butyl 6-cyano-5-hydroxy-3-oxohexanoate  
**CAS No.:** 312745-90-7  
**Cat. No.:** B1458446

[Get Quote](#)

Content Type: Publish Comparison Guide Audience: Researchers, Analytical Scientists, and Drug Development Professionals Version: 2.0 (High-Resolution MS Focus)[1]

## Executive Summary: The Isobaric Challenge

In the generic development of Atorvastatin Calcium, the distinction between synthesis precursors, active pharmaceutical ingredients (API), and degradation products is complicated by isobaric interferences and structurally homologous fragmentation patterns.

This guide moves beyond standard pharmacopeial monographs to provide a mechanistic MS/MS comparison of Atorvastatin's key precursors (Paal-Knorr intermediates) and its critical impurities.[1] We focus on the "Decision Tree" logic required to distinguish the Lactone form (m/z 541) from the Desfluoro impurity (m/z 541) and characterize the Amine side-chain precursor (m/z 274), ensuring strict control over the Paal-Knorr condensation step.[1]

## Comparative Analysis: Ionization & Instrumentation

For trace-level precursor analysis, Electrospray Ionization (ESI) in positive mode (ESI+) is the industry standard due to the basic nitrogen atoms in the pyrrole and amide moieties. While APCI is an alternative for non-polar intermediates, ESI+ provides superior sensitivity for the polar amine side chains.

Feature	Triple Quadrupole (QqQ)	Q-TOF / Orbitrap (HRMS)	Recommendation
Primary Use	Quantitative (MRM)	Qualitative (Structure Elucidation)	Use Q-TOF for R&D/Pathway mapping; QqQ for QC release.[1]
Mass Accuracy	Unit Resolution (0.7 Da)	< 5 ppm	Crucial: HRMS is required to distinguish Desfluoro (-F, +H) from Lactone (-H <sub>2</sub> O) if mass resolution is < 20k.[1]
Sensitivity	High (pg/mL range)	Medium-High	QqQ is preferred for trace "genotoxic" precursor quantitation. [1]

## Deep Dive: Fragmentation Pathways

### A. The Synthesis Precursors (Paal-Knorr Intermediates)

Controlling the stoichiometry of the Paal-Knorr reaction is vital.[1] Residual precursors must be monitored.

#### 1. The Amine Intermediate (TBIN)[1]

- Chemical Name: (4R,6R)-tert-Butyl-6-(2-aminoethyl)-2,2-dimethyl-1,3-dioxane-4-acetate[1][2][3][4][5][6]
- Formula: C<sub>14</sub>H<sub>27</sub>NO<sub>4</sub>[1][2][6]

- Precursor Ion [M+H]<sup>+</sup>: m/z 274.2[1]

Fragmentation Pattern: The fragmentation is dominated by the instability of the protecting groups (tert-butyl ester and acetonide).

- m/z 218: Loss of isobutene (C<sub>4</sub>H<sub>8</sub>, -56 Da) from the tert-butyl ester.[1]
- m/z 160: Secondary loss of acetone (C<sub>3</sub>H<sub>6</sub>, -58 Da) from the acetonide ring.
- Diagnostic Utility: The transition 274 → 218 is highly specific for monitoring unreacted amine side chains.

## 2. The Diketone Intermediate

- Chemical Name: 4-Fluoro- $\alpha$ -(2-methyl-1-oxopropyl)- $\gamma$ -oxo-N, $\beta$ -diphenylbenzenebutanamide[1]
- Formula: C<sub>26</sub>H<sub>23</sub>FNO<sub>3</sub>[1]
- Precursor Ion [M+H]<sup>+</sup>: m/z 416.2[1]

Fragmentation Pattern: This molecule contains the amide bond responsible for the signature fragmentation of the final drug.

- m/z 323: Loss of Aniline (C<sub>6</sub>H<sub>5</sub>NH<sub>2</sub>, -93 Da).[1] This confirms the presence of the intact amide backbone.
- m/z 297: Loss of Phenyl Isocyanate (C<sub>6</sub>H<sub>5</sub>NCO, -119 Da).[1]

## B. The API: Atorvastatin Calcium[5][7]

- Precursor Ion [M+H]<sup>+</sup>: m/z 559.3[1]
- Core Mechanism: Protonation occurs on the amide nitrogen or the pyrrole ring, triggering cleavage of the amide side chain.

Key Diagnostic Ions:

- m/z 466.2:  $[M+H - \text{Aniline}]^+$ . The most abundant product ion, formed by inductive cleavage of the amide bond.
- m/z 440.2:  $[M+H - \text{Phenyl Isocyanate}]^+$ .<sup>[1]</sup> A competitive pathway involving a 4-membered transition state.<sup>[1]</sup>
- m/z 422.2:  $[m/z 440 - \text{H}_2\text{O}]^+$ . Dehydration of the m/z 440 fragment.

## C. The Isobaric Trap: Lactone vs. Desfluoro

Both compounds appear at m/z 541, but their origins and toxicological implications differ.

- Atorvastatin Lactone (ATL): Formed by acid-catalyzed cyclization (Degradant).<sup>[1]</sup>
- Desfluoro-Atorvastatin (DesF): Formed by defluorination during synthesis (Process Impurity).<sup>[1]</sup>

Differentiation Strategy (MS3): Standard MS2 (m/z 541 → 448) is identical for both (loss of aniline).<sup>[1]</sup> You must use MS3 or high-resolution fragments to distinguish them.

Compound	Precursor	MS2 Fragment	MS3 Fragment (from 448)	Mechanism
Lactone	541	448	m/z 388	Loss of H <sub>2</sub> O + CO <sub>2</sub> (Lactone ring opening/decarbonylation)
Desfluoro	541	448	m/z 412	Sequential loss of 2 x H <sub>2</sub> O (Open acid chain dehydration)

## Visualized Pathways (Graphviz)<sup>[1]</sup>

### Diagram 1: Atorvastatin Fragmentation Pathway

This diagram illustrates the primary cleavage points for the API.

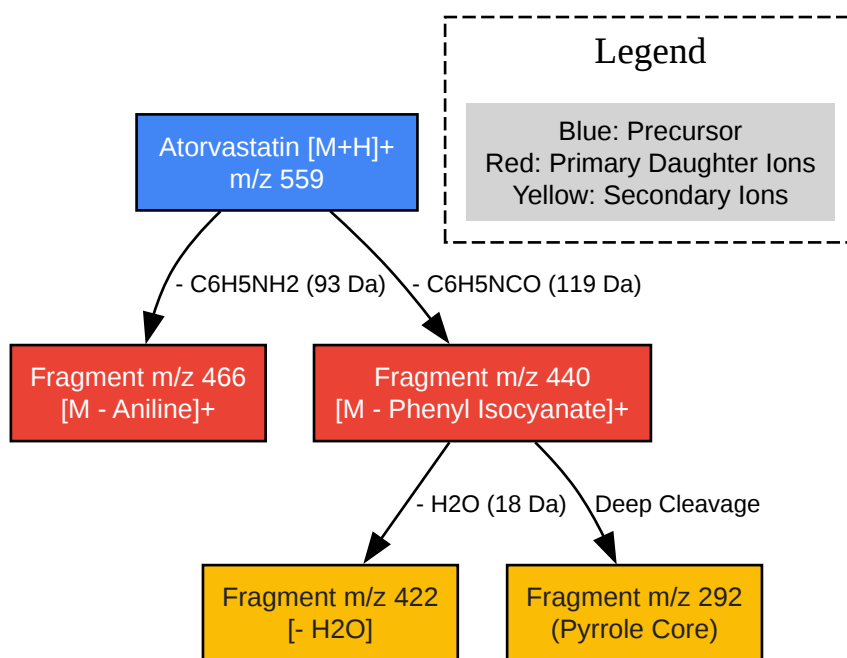

[Click to download full resolution via product page](#)

Caption: Primary ESI<sup>+</sup> fragmentation pathway of Atorvastatin showing competitive loss of aniline and phenyl isocyanate.[1]

## Diagram 2: The m/z 541 Decision Tree

A logic flow for distinguishing isobaric impurities.

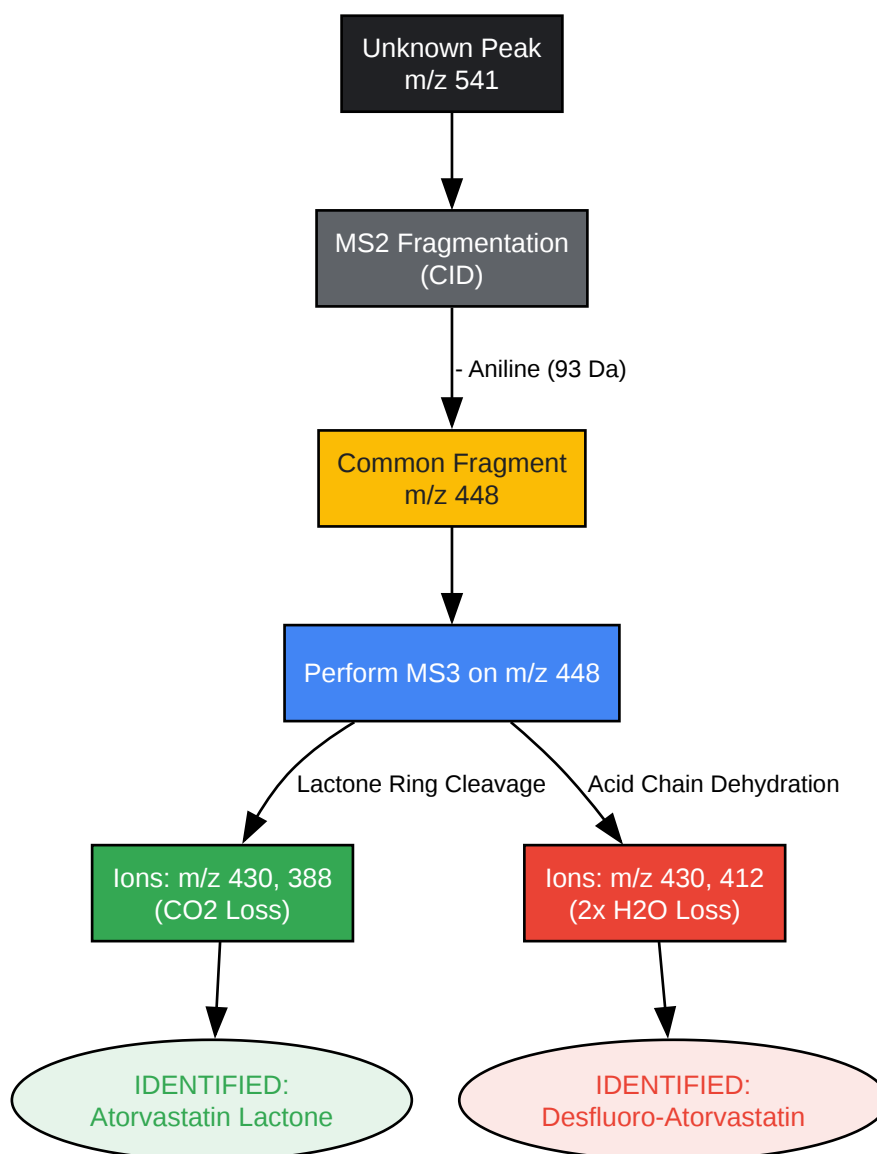

[Click to download full resolution via product page](#)

Caption: MS3 workflow to distinguish Atorvastatin Lactone from Desfluoro-Atorvastatin (both m/z 541).

## Experimental Protocol: Impurity Profiling Workflow

Objective: Simultaneous detection of Amine precursor, Diketone precursor, and Lactone impurity.

### 1. Sample Preparation:

- Solvent: Acetonitrile:Water (50:[1]50) with 0.1% Formic Acid.[7]
- Concentration: 10 µg/mL (for qualitative ID); 10 ng/mL (for trace quantitation).
- Stability Warning: Maintain samples at 4°C. Atorvastatin acid converts to lactone at room temperature in acidic media.

## 2. LC Conditions:

- Column: C18 Phenyl-Hexyl (Provides better selectivity for aromatic impurities than standard C18).[1]
- Mobile Phase A: 0.1% Formic Acid in Water.[7]
- Mobile Phase B: 0.1% Formic Acid in Acetonitrile.
- Gradient: 5% B to 95% B over 10 mins.

## 3. MS Parameters (ESI+):

- Capillary Voltage: 3.5 kV.
- Source Temp: 350°C.
- Collision Energy (CE):
  - Stepped CE (15, 30, 45 eV) is recommended to capture both fragile (water loss) and backbone (aniline loss) fragments in a single run.

## 4. Data Processing:

- Extract Ion Chromatograms (EIC) for:
  - m/z 274.2 (Amine Precursor)[1]
  - m/z 416.2 (Diketone Precursor)[1]
  - m/z 559.3 (Atorvastatin)[1]

- m/z 541.3 (Lactone/Desfluoro window)[1]

## References

- Shandilya, D., et al. (2017).[8] Prediction of the Fragmentation Pathway of Atorvastatin by Using High Resolution Collision Induced Dissociation (HR-MS/MS) Spectral Information. Open Access Library Journal.[8] [[Link](#)]
- Mornar, A., et al. (2010).[9] Separation, Characterization, and Quantification of Atorvastatin and Related Impurities by Liquid Chromatography-Electrospray Ionization Mass Spectrometry. Analytical Letters. [[Link](#)]
- Vukkum, P., et al. (2013). Stress Degradation Behavior of Atorvastatin Calcium and Development of a Suitable Stability-Indicating LC Method. Scientia Pharmaceutica. [[Link](#)]
- PubChem Compound Summary. (2025). Atorvastatin Acetonide tert-Butyl Ester (Intermediate).[1][5] National Center for Biotechnology Information. [[Link](#)][1]
- Koterawsa, K., et al. (2022).[10] Analysis of Impurities in Atorvastatin Using Single Quadrupole Mass Spectrometer. Shimadzu Application News. [[Link](#)](Note: Link directs to general resource as specific App Note is dynamic).

### Need Custom Synthesis?

BenchChem offers custom synthesis for rare earth carbides and specific isotopic labeling.

Email: [info@benchchem.com](mailto:info@benchchem.com) or [Request Quote Online](#).

## Sources

- 1. Atorvastatin Acetonide tert-Butyl Ester | C<sub>40</sub>H<sub>47</sub>FN<sub>2</sub>O<sub>5</sub> | CID 10168503 - PubChem [[pubchem.ncbi.nlm.nih.gov](https://pubchem.ncbi.nlm.nih.gov)]
- 2. (4R,6R)-tert-Butyl-6-(2-aminoethyl)-2,2-dimethyl-1,3-dioxane-4-acetate | C<sub>14</sub>H<sub>27</sub>NO<sub>4</sub> | CID 2734288 - PubChem [[pubchem.ncbi.nlm.nih.gov](https://pubchem.ncbi.nlm.nih.gov)]
- 3. The Asymmetric Synthesis of tert-Butyl (4R,6R)-6-(2-aminoethyl)-2,2-dimethyl-1,3-dioxane-4-acetate: An Important Intermediate of HMG-CoA Reductase Inhibitor [[internationaljournals.srg.org](https://internationaljournals.srg.org)]

- [4. chemscene.com \[chemscene.com\]](#)
- [5. researchgate.net \[researchgate.net\]](#)
- [6. \(4R,6R\)-tert-Butyl-6-\(2-aminoethyl\)-2,2-dimethyl-1,3-dioxane-4-acetate | 125995-13-3 \[chemicalbook.com\]](#)
- [7. mdpi.com \[mdpi.com\]](#)
- [8. Prediction of the Fragmentation Pathway of Atorvastatin by Using High Resolution Collision Induced Dissociation \(HR-MS/MS\) Spectral Information \[scirp.org\]](#)
- [9. waters.com \[waters.com\]](#)
- [10. lcms.cz \[lcms.cz\]](#)
- To cite this document: BenchChem. [Precision Profiling: MS/MS Fragmentation Guide for Atorvastatin Precursors]. BenchChem, [2026]. [Online PDF]. Available at: [\[https://www.benchchem.com/product/b1458446/docs#precision-profiling-ms-ms-fragmentation-guide-for-atorvastatin-precursors\]](https://www.benchchem.com/product/b1458446/docs#precision-profiling-ms-ms-fragmentation-guide-for-atorvastatin-precursors)

---

#### Disclaimer & Data Validity:

The information provided in this document is for Research Use Only (RUO) and is strictly not intended for diagnostic or therapeutic procedures. While BenchChem strives to provide accurate protocols, we make no warranties, express or implied, regarding the fitness of this product for every specific experimental setup.

**Technical Support:** The protocols provided are for reference purposes. Unsure if this reagent suits your experiment?

**Need Industrial/Bulk Grade?** [Request Custom Synthesis Quote](#)

## BenchChem

Our mission is to be the trusted global source of essential and advanced chemicals, empowering scientists and researchers to drive progress in science and industry.

#### Contact

Address: 3281 E Guasti Rd  
Ontario, CA 91761, United States  
Phone: (601) 213-4426  
Email: [info@benchchem.com](mailto:info@benchchem.com)

Contact our Ph.D. Support Team for a compatibility check