

Technical Support Center: Isoxazole Synthesis & Stability

Author: BenchChem Technical Support Team. **Date:** May 2026

Compound of Interest

Compound Name: (3-Isobutylisoxazol-5-yl)methanol

CAS No.: 71502-42-6

Cat. No.: B1338110

[Get Quote](#)

Status: Online | Tier: Advanced Research Support | Topic: Reactant Decomposition

Welcome to the Isoxazole Synthesis Support Hub

User Context: You are encountering yield loss due to reactant decomposition during isoxazole scaffold construction. System Overview: Isoxazoles are critical pharmacophores (e.g., Valdecoxib, Leflunomide), but their synthesis is plagued by the thermodynamic instability of key intermediates—specifically nitrile oxides and 1,3-dicarbonyls.

This guide treats your chemical reaction as a "system" that requires debugging. Below are the three most common "Error Codes" (failure modes) and their corresponding patch protocols.

Ticket #001: Nitrile Oxide Dimerization (The "Furoxan" Error)

Severity: Critical Symptoms: Low yield of isoxazole; isolation of a crystalline byproduct (furoxan); reaction mixture turns milky/opaque rapidly.

Root Cause Analysis

In [3+2] cycloadditions (Huisgen reaction), the nitrile oxide intermediate is a "hot" species. It possesses a high dipole moment and is electrophilic. If the dipolarophile (alkyne/alkene) is not immediately available or if the local concentration of the nitrile oxide is too high, it self-reacts via a diradical stepwise mechanism to form a furoxan (1,2,5-oxadiazole-2-oxide) dimer.

Key Mechanic: Dimerization is second-order with respect to nitrile oxide concentration (), whereas cycloaddition is first-order with respect to the nitrile oxide (). Therefore, keeping low is the only way to favor the product.

Visualizing the Pathway Competition

The following diagram illustrates the kinetic competition you must manage.

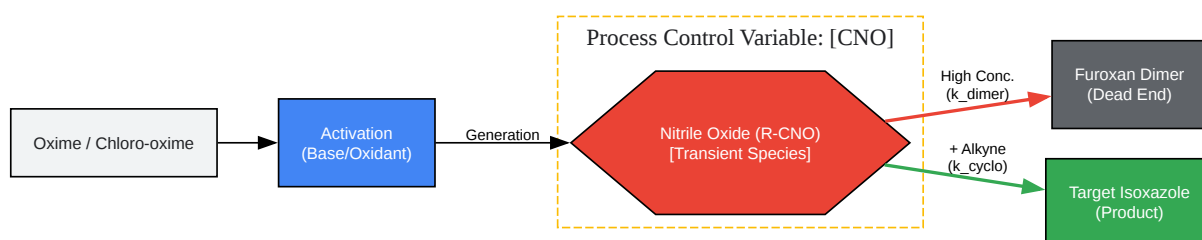

[Click to download full resolution via product page](#)

Figure 1: Kinetic competition between productive cycloaddition and destructive dimerization.

Resolution Protocol: The "In Situ" Slow-Release Patch

Do not isolate nitrile oxides. Generate them in the presence of the dipolarophile using a slow-release oxidant.

Reagents:

- Substrate: Aldoxime (1.0 equiv)

- Dipolarophile: Alkyne (1.1–1.5 equiv)
- Oxidant: Chloramine-T (trihydrate)
- Solvent: Ethanol or MeOH (Green chemistry compatible)

Step-by-Step:

- Dissolution: Dissolve the aldoxime and the alkyne in Ethanol (0.1 M concentration relative to aldoxime).
- Catalyst Prep: No base is needed if using Chloramine-T, as it acts as both halogenating agent and base.
- Addition: Add Chloramine-T (1.1 equiv) in three equal portions over 30 minutes at Room Temperature (RT).
 - Why? This keeps the instantaneous
low, favoring the first-order reaction with the alkyne over the second-order dimerization.
- Reflux: Heat to 60°C for 2–4 hours to drive the cycloaddition.
- Workup: Remove solvent, wash with water (removes sulfonamide byproduct), and extract with EtOAc.

Ticket #002: 1,3-Dicarbonyl Fragmentation (The "Retro-Claisen" Error)

Severity: High Symptoms: Disappearance of starting material but no isoxazole formation; formation of simple esters or ketones; low regioselectivity.

Root Cause Analysis

In the condensation method (Hydroxylamine + 1,3-Dicarbonyl), the reaction environment is often acidic (using

) or basic (using

).

- **Retro-Claisen Cleavage:** 1,3-dicarbonyls are susceptible to nucleophilic attack at the carbonyl carbon. Strong bases or prolonged heating can cleave the C-C bond between the carbonyls, destroying the scaffold before the isoxazole forms.
- **Regio-scrambling:** Unsymmetrical diketones possess two electrophilic sites. Standard conditions often yield a 50:50 mixture of regioisomers (3,5- vs 5,3-substituted).

Data Table: Optimization of Condensation Conditions

Parameter	Standard Condition (Risk)	Optimized Condition (Safe Mode)	Mechanism of Improvement
pH Control	Strong Base (NaOEt/NaOH)	Buffered (NaOAc / AcOH)	Prevents anionic retro-Claisen cleavage of the diketone.
Solvent	Refluxing Ethanol	Aqueous Alcohol (RT to 50°C)	Lower temperature reduces thermal decomposition rates.
Reagent	Hydroxylamine HCl	Free Hydroxylamine (generated)	Avoids strong acid catalysis that can degrade sensitive substrates.
Surrogate	-Keto Ester	-Enaminone	Enaminones are less prone to hydrolysis and direct regioselectivity (N attacks C-O, O attacks C-N).

Resolution Protocol: The Enaminone Surrogate Route

If your dicarbonyl decomposes, convert it to an enaminone first. This "masks" the instability and locks regioselectivity.

- Masking: React 1,3-dicarbonyl with DMF-DMA (Dimethylformamide dimethyl acetal) in toluene (Reflux, 2h)

Yields

-enaminone.

- Cyclization: Treat the isolated enaminone with

in Ethanol at Reflux.
- Result: Exclusive formation of the 5-substituted isoxazole with minimal decomposition.

Ticket #003: Thermal Instability & Scale-up (Flow Chemistry)

Severity: Moderate (Safety Hazard on Scale) Symptoms: Exotherms during activation; accumulation of explosive intermediates; degradation due to long residence times in batch.

Root Cause Analysis

Batch reactors suffer from poor heat transfer. Generating exothermic intermediates (like nitrile oxides or chloro-oximes) in bulk creates "hot spots" that accelerate decomposition.

Resolution Protocol: Telescoped Flow Synthesis

Move the process to a continuous flow reactor. This allows you to generate the unstable intermediate and consume it immediately (seconds vs. hours).

Workflow Logic:

- Zone 1 (Generation): Aldehyde +

Oxime (Fast).
- Zone 2 (Chlorination): Oxime + NCS (N-Chlorosuccinimide)

Chloro-oxime.
- Zone 3 (Trapping): Chloro-oxime + Alkyne + Base

Isoxazole.

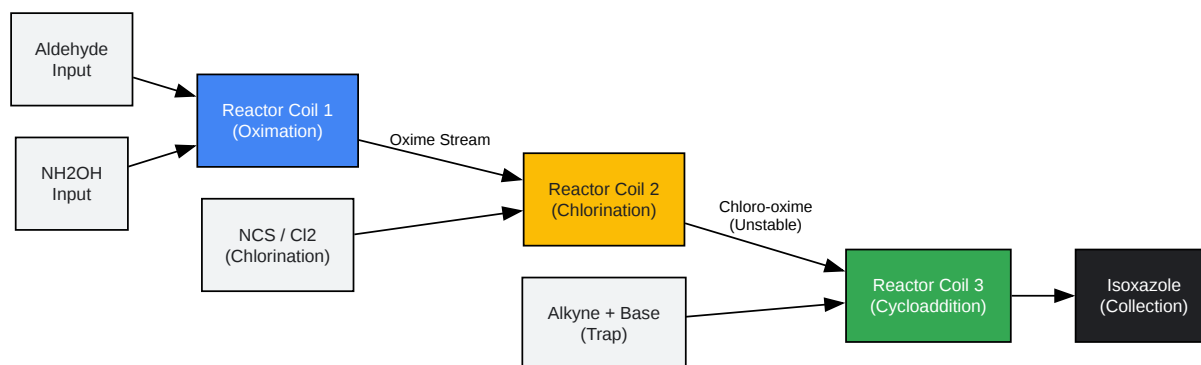

[Click to download full resolution via product page](#)

Figure 2: Telescoped flow synthesis prevents the accumulation of unstable chloro-oxime intermediates.

Frequently Asked Questions (FAQ)

Q: My nitrile oxide reaction works for aryl alkynes but fails for alkyl alkynes. Why? A: Alkyl alkynes are less activated dipolarophiles. The reaction rate is slower, allowing dimerization to dominate. Fix: Increase the equivalents of the alkyne (to 3.0 equiv) or switch to a Copper-Catalyzed (CuAAC-like) protocol using Cu(I) to activate the terminal alkyne (See Hansen et al. in References).

Q: Can I use microwave irradiation to speed up the condensation? A: Use caution. While microwaves accelerate the reaction, they can also accelerate the retro-Claisen cleavage of 1,3-dicarbonyls. If you use MW, use the Enaminone route (Ticket #002), which is thermally stable enough to withstand the rapid heating.

Q: How do I remove the furoxan byproduct if it forms? A: Furoxans are much less polar than isoxazoles. They can usually be separated via column chromatography using a non-polar eluent (e.g., 5% EtOAc in Hexanes). However, prevention is far superior to purification.

References

- Huisgen, R. (1963). 1,3-Dipolar Cycloadditions.[1][2][3][4][5] Past and Future. Angewandte Chemie International Edition. [Link](#)
- Hansen, T. V., Wu, P., & Fokin, V. V. (2005).[6] One-Pot Copper(I)-Catalyzed Synthesis of 3,5-Disubstituted Isoxazoles. The Journal of Organic Chemistry. [Link](#)
- Prieschl, M., et al. (2023).[7] Leveraging flow chemistry for the synthesis of trisubstituted isoxazoles. Journal of Flow Chemistry.[7] [Link](#)
- Pfeiffer, J. Y., & Beauchemin, A. M. (2009).[8] Simple Reaction Conditions for the Formation of Ketonitrones from Ketones and Hydroxylamines. The Journal of Organic Chemistry. [Link](#)
- Tang, S., et al. (2009).[6] Efficient Synthesis of Isoxazoles via Reaction of N-Hydroxyl-4-toluenesulfonamide with α,β -Unsaturated Carbonyl Compounds.[6] Organic Letters.[6] [Link](#)

Need Custom Synthesis?

BenchChem offers custom synthesis for rare earth carbides and specific isotopic labeling.

Email: info@benchchem.com or [Request Quote Online](#).

Sources

- 1. Diazocarbonyl and Related Compounds in the Synthesis of Azoles - PMC [[pmc.ncbi.nlm.nih.gov](https://pubmed.ncbi.nlm.nih.gov)]
- 2. pdf.benchchem.com [pdf.benchchem.com]
- 3. mdpi.com [mdpi.com]
- 4. researchgate.net [researchgate.net]
- 5. researchgate.net [researchgate.net]
- 6. Isoxazole synthesis [organic-chemistry.org]
- 7. researchgate.net [researchgate.net]
- 8. Simple Reaction Conditions for the Formation of Ketonitrones from Ketones and Hydroxylamines [organic-chemistry.org]

- To cite this document: BenchChem. [Technical Support Center: Isoxazole Synthesis & Stability]. BenchChem, [2026]. [Online PDF]. Available at: [<https://www.benchchem.com/product/b1338110/docs#technical-support-center-isoxazole-synthesis-stability>]

Disclaimer & Data Validity:

The information provided in this document is for Research Use Only (RUO) and is strictly not intended for diagnostic or therapeutic procedures. While BenchChem strives to provide accurate protocols, we make no warranties, express or implied, regarding the fitness of this product for every specific experimental setup.

Technical Support: The protocols provided are for reference purposes. Unsure if this reagent suits your experiment?

Need Industrial/Bulk Grade? [Request Custom Synthesis Quote](#)

BenchChem

Our mission is to be the trusted global source of essential and advanced chemicals, empowering scientists and researchers to drive progress in science and industry.

Contact

Address: 3281 E Guasti Rd
Ontario, CA 91761, United States
Phone: (601) 213-4426
Email: info@benchchem.com

[Contact our Ph.D. Support Team for a compatibility check](#)