

Comparative Guide: Reactivity & Stability of Dichlorinated Methoxybiphenyl Isomers

Author: BenchChem Technical Support Team. **Date:** May 2026

Compound of Interest

Compound Name: 1,3-Dichloro-5-(3-methoxyphenyl)benzene
CAS No.: 1375068-81-7
Cat. No.: B1457152

[Get Quote](#)

Executive Summary: Electronic & Steric Landscape

The reactivity of dichlorinated methoxybiphenyls is governed by the competing effects of the methoxy group (+M, -I) and the chlorine atoms (+M, -I, steric bulk).

Feature	Shielded Core (3,5-Cl-4-OMe)	Distal (3',4'-Cl-4-OMe)	Orthogonal (2,4-Cl-4'-OMe)
Electronic State (Ring A)	Electron-Deficient (Inductive withdrawal by 2 Cl)	Electron-Rich (Activated by OMe)	Moderate (Deactivated by Cl, twisted)
Steric Hindrance	High (OMe is flanked)	Low (Planar conformation possible)	High (Biaryl twist prevents planarity)
Primary Metabolic Risk	O-Demethylation (Slowed by steric shield)	Ring Hydroxylation (High risk on Ring A)	Mixed
Key Application	Metabolic Blocker / Lipophilicity Booster	Electronic Tuning / Conjugation	Conformational Locking

Reactivity Profile: Electrophilic Aromatic Substitution (EAS)

In drug synthesis, late-stage functionalization often relies on EAS (e.g., halogenation, nitration). [1] The position of the chlorine atoms dramatically shifts the "soft spot" of the molecule.

Mechanism & Regioselectivity

- **Shielded Core Isomer:** The A-ring is sterically crowded. Although OMe is a strong activator, the 3,5-dichloro substitution forces incoming electrophiles to the B-ring (the non-substituted phenyl ring).[1]
 - Outcome: Reaction occurs almost exclusively at the 4'-position (para to the biaryl bond) of the B-ring.
- **Distal Isomer:** The A-ring (containing OMe) is highly activated. The B-ring is deactivated by dichlorine substitution.
 - Outcome: Reaction occurs at the 3-position (ortho to OMe) on the A-ring.

- Orthogonal Isomer: The 2-chloro substituent forces the two rings out of planarity (dihedral angle $\sim 60-90^\circ$), breaking conjugation. The rings react independently.
 - Outcome: The OMe-bearing ring reacts much faster than the dichloro ring.

Visualizing the Activation Pathways

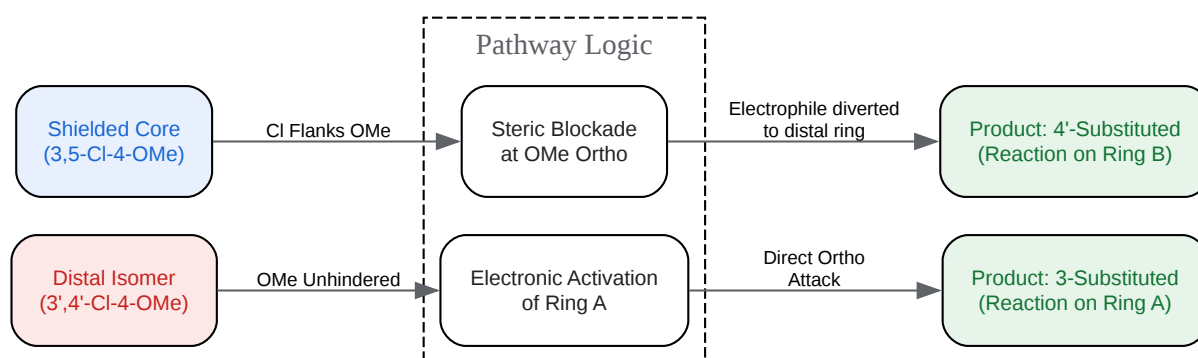

[Click to download full resolution via product page](#)

Figure 1: Divergent regioselectivity driven by steric shielding vs. electronic activation.[1]

Metabolic Stability: CYP450 Oxidation

For drug development professionals, the metabolic fate of these isomers is the most critical differentiator.

Comparative Metabolic Soft Spots

Isomer	Primary Metabolite	CYP450 Mechanism	Stability Rating
Shielded Core	Stable (Minor O-demethylation)	The 3,5-dichloro pattern sterically hinders the CYP450 heme iron from accessing the methoxy carbon [1],[1]	High
Distal Isomer	Unstable (Ring Hydroxylation)	The electron-rich Ring A is prone to oxidation at the 3-position (ortho to OMe).	Low
Orthogonal	Moderate	The twist prevents conjugation, making the OMe ring susceptible, but the Cl ring resistant.[1]	Medium

Expert Insight: The "Shielded Core" motif is frequently employed in agrochemicals (e.g., Dicamba analogs) and modern kinase inhibitors to extend half-life (

).[1] The chlorine atoms act as "metabolic armor."

Experimental Protocols

Protocol A: Synthesis via Suzuki-Miyaura Cross-Coupling

Objective: To synthesize the "Distal Isomer" (3',4'-dichloro-4-methoxybiphenyl) with high regiocontrol.[1]

Reagents:

- 4-Methoxyphenylboronic acid (1.2 equiv)[1]
- 1-Bromo-3,4-dichlorobenzene (1.0 equiv)[1]
- Pd(dppf)Cl₂ (3 mol%)[1]

- K₂CO₃ (2.0 M aqueous)[1]
- Dioxane[1]

Step-by-Step Workflow:

- Degassing: Charge a reaction vial with the aryl halide and boronic acid. Evacuate and backfill with Argon (3x) to remove O₂ (critical to prevent homocoupling).[1]
- Solvation: Add Dioxane (0.2 M concentration relative to halide).
- Catalyst Addition: Add Pd(dppf)Cl₂. [1] The dppf ligand is chosen for its large bite angle, which accelerates the reductive elimination step for sterically demanding substrates [2].
- Activation: Add K₂CO₃ solution. Heat to 90°C for 12 hours.
- Validation: Monitor via TLC (Hexane/EtOAc 9:1). The product will be less polar than the boronic acid but more polar than the di-halo starting material.
- Purification: Silica gel chromatography.

Protocol B: Metabolic Stability Assay (Microsomal Stability)

Objective: To quantify the intrinsic clearance (

) of the isomers.[1]

- Preparation: Prepare a 10 mM stock of the test isomer in DMSO.
- Incubation: Dilute to 1 μM in phosphate buffer (pH 7.4) containing 0.5 mg/mL liver microsomes (human or rat).[1]
- Initiation: Pre-incubate at 37°C for 5 min. Start reaction by adding NADPH (1 mM final).[1]
- Sampling: Aliquot 50 μL at t=0, 5, 15, 30, and 60 min into cold acetonitrile (to quench protein).
- Analysis: Centrifuge and analyze supernatant via LC-MS/MS.

- Calculation: Plot $\ln(\% \text{ remaining})$ vs. time. Slope =

[1]

◦ [1]

◦ [1]

Synthesis & Functionalization Workflow

The following diagram outlines the decision tree for synthesizing these isomers, highlighting the necessary starting materials to achieve the desired substitution pattern.

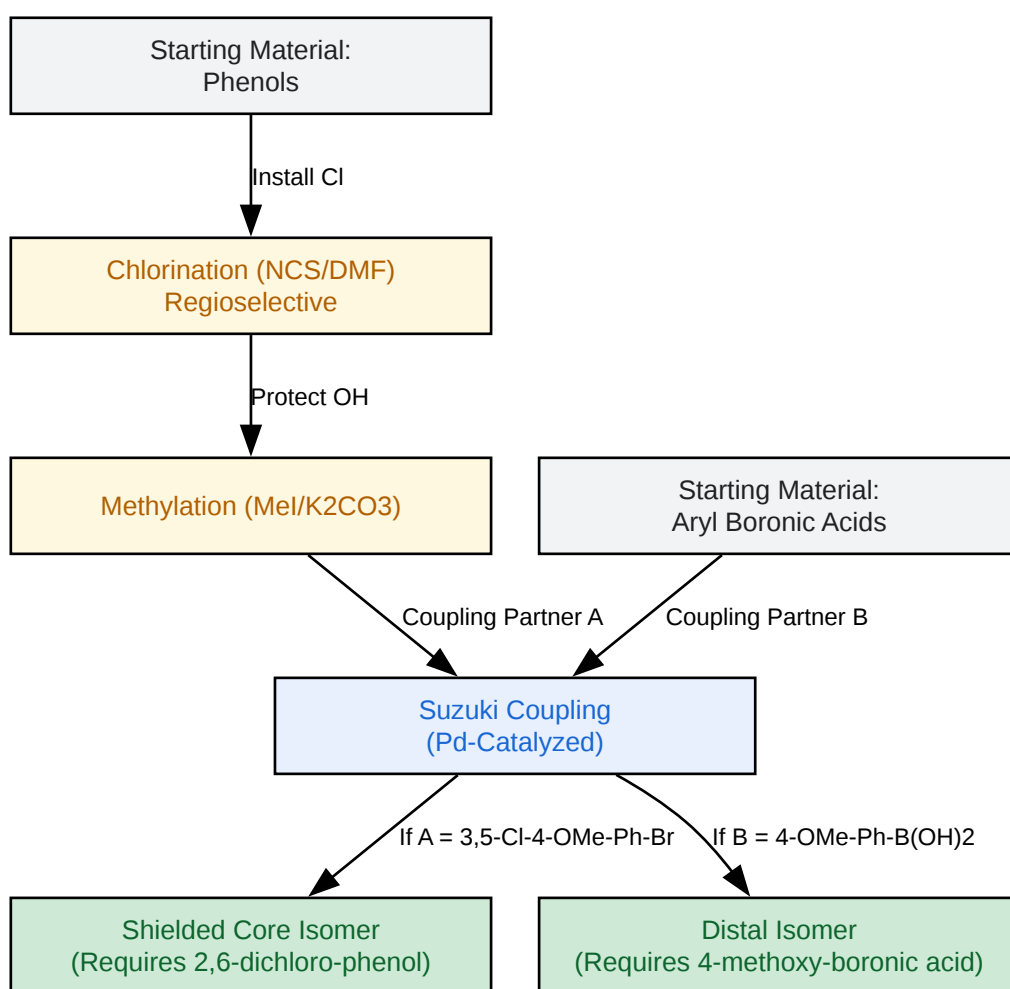

[Click to download full resolution via product page](#)

Figure 2: Retrosynthetic analysis for targeted isomer construction.

References

- Metabolic Stability of Fluorinated Small Molecules. PubMed. (2026). Explores the mechanistic rationale for halogen-induced metabolic stability, relevant to chlorinated analogs.
- Site Selective Chlorination of C(sp³)-H Bonds. Angewandte Chemie. (2021). Discusses copper-catalyzed chlorination and the steric parameters influencing site selectivity.
- Identification of Chlorinated Dimethoxystilbene Isomers. Analytical Chemistry. (2000). Provides mass spectral data for distinguishing isomeric chlorinated methoxy-aromatics. [1]
- BenchChem Technical Guide: Dichloronitrobenzene Isomers. BenchChem. (2025). [2]
Detailed synthesis data on dichlorinated aromatic precursors. [1]

Need Custom Synthesis?

BenchChem offers custom synthesis for rare earth carbides and specific isotopic labeling.

Email: info@benchchem.com or [Request Quote Online](#).

Sources

- 1. TW200427671A - Pyrazolone compounds and thrombopoietin receptor activator - Google Patents [patents.google.com]
- 2. pdf.benchchem.com [pdf.benchchem.com]
- To cite this document: BenchChem. [Comparative Guide: Reactivity & Stability of Dichlorinated Methoxybiphenyl Isomers]. BenchChem, [2026]. [Online PDF]. Available at: [<https://www.benchchem.com/product/b1457152/docs#comparative-guide-reactivity-stability-of-dichlorinated-methoxybiphenyl-isomers>]

Disclaimer & Data Validity:

The information provided in this document is for Research Use Only (RUO) and is strictly not intended for diagnostic or therapeutic procedures. While BenchChem strives to provide accurate protocols, we make no warranties, express or implied, regarding the fitness of this product for every specific experimental setup.

Technical Support: The protocols provided are for reference purposes. Unsure if this reagent suits your experiment?

Need Industrial/Bulk Grade? [Request Custom Synthesis Quote](#)

BenchChem

Our mission is to be the trusted global source of essential and advanced chemicals, empowering scientists and researchers to drive progress in science and industry.

Contact

Address: 3281 E Guasti Rd
Ontario, CA 91761, United States
Phone: (601) 213-4426
Email: info@benchchem.com

[Contact our Ph.D. Support Team for a compatibility check](#)