

# Application Note & Protocols: Strategic Esterification of 5-Chloro-4-hydroxynicotinic Acid

**Author:** BenchChem Technical Support Team. **Date:** April 2026

## Compound of Interest

Compound Name:	5-Chloro-4-hydroxynicotinic acid
CAS No.:	1211591-92-2
Cat. No.:	B1457750

[Get Quote](#)

## Abstract & Introduction

**5-Chloro-4-hydroxynicotinic acid** is a substituted pyridine derivative of significant interest in medicinal chemistry and drug development. Its structural motifs are found in various biologically active compounds. The strategic esterification of its carboxylic acid moiety is a critical step in the synthesis of novel molecular entities, enabling the modulation of physicochemical properties such as solubility, lipophilicity, and metabolic stability. This document provides a comprehensive guide for researchers, detailing two robust protocols for the selective esterification of the carboxylic acid group: the classic Fischer-Speier esterification under acidic conditions and the milder, coupling agent-mediated Steglich esterification. The rationale behind methodological choices, detailed step-by-step protocols, and expected outcomes are presented to ensure reproducible and efficient synthesis.

## Chemical Principles and Method Selection

The molecular structure of **5-Chloro-4-hydroxynicotinic acid** presents two key functional groups: a carboxylic acid and a phenolic hydroxyl group. The primary objective is the selective

esterification of the carboxylic acid. The choice of method depends on the stability of the starting material and the desired reaction conditions (e.g., mild vs. harsh).

## Fischer-Speier Esterification

This method involves the direct reaction of a carboxylic acid with an excess of alcohol under strong acid catalysis (e.g.,  $\text{H}_2\text{SO}_4$ , *p*-TsOH).[1][2][3] The reaction is an equilibrium process, and to drive it towards the product, either the alcohol is used in large excess as the solvent, or water is removed as it is formed.[4][5][6]

- **Mechanism:** The reaction begins with the protonation of the carbonyl oxygen of the carboxylic acid by the strong acid catalyst. This activation increases the electrophilicity of the carbonyl carbon, making it susceptible to nucleophilic attack by the alcohol. A tetrahedral intermediate is formed, followed by proton transfer and the elimination of a water molecule to yield the protonated ester. Final deprotonation regenerates the acid catalyst and provides the ester product.[3][5][7]
- **Applicability:** This is a cost-effective and straightforward method, particularly for simple alkyl esters (e.g., methyl, ethyl). A reliable procedure for the ethyl esterification of the closely related 5-hydroxynicotinic acid has been published in *Organic Syntheses*, demonstrating its viability for this class of compounds.

## Steglich Esterification

For substrates that are sensitive to high temperatures or strong acids, the Steglich esterification offers a mild and highly efficient alternative.[8][9] This reaction utilizes a carbodiimide coupling agent, such as *N,N'*-dicyclohexylcarbodiimide (DCC) or 1-ethyl-3-(3-dimethylaminopropyl)carbodiimide (EDC), in the presence of a nucleophilic catalyst, typically 4-dimethylaminopyridine (DMAP).[10][11]

- **Mechanism:** The carboxylic acid first reacts with the carbodiimide (DCC) to form a highly reactive *O*-acylisourea intermediate. DMAP, being a stronger nucleophile than the alcohol, then intercepts this intermediate to form a reactive *N*-acylpyridinium species ("active ester"). This species readily undergoes nucleophilic attack by the alcohol to form the desired ester, releasing DMAP. The DCC is consumed by abstracting a molecule of water, forming the insoluble dicyclohexylurea (DCU) byproduct.[8][9]

- **Applicability:** The Steglich method is particularly advantageous for sterically hindered substrates or when mild, room-temperature conditions are required.<sup>[10][11]</sup> It avoids the harshness of strong acids and high heat, preserving sensitive functional groups.

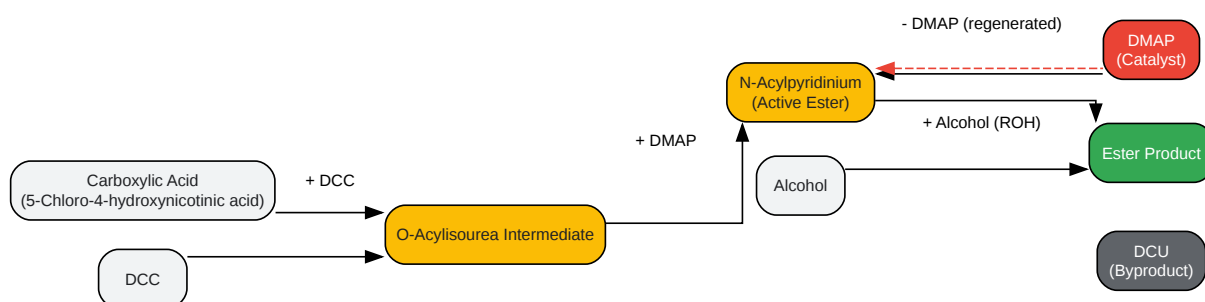

Diagram 1: Steglich Esterification Mechanism

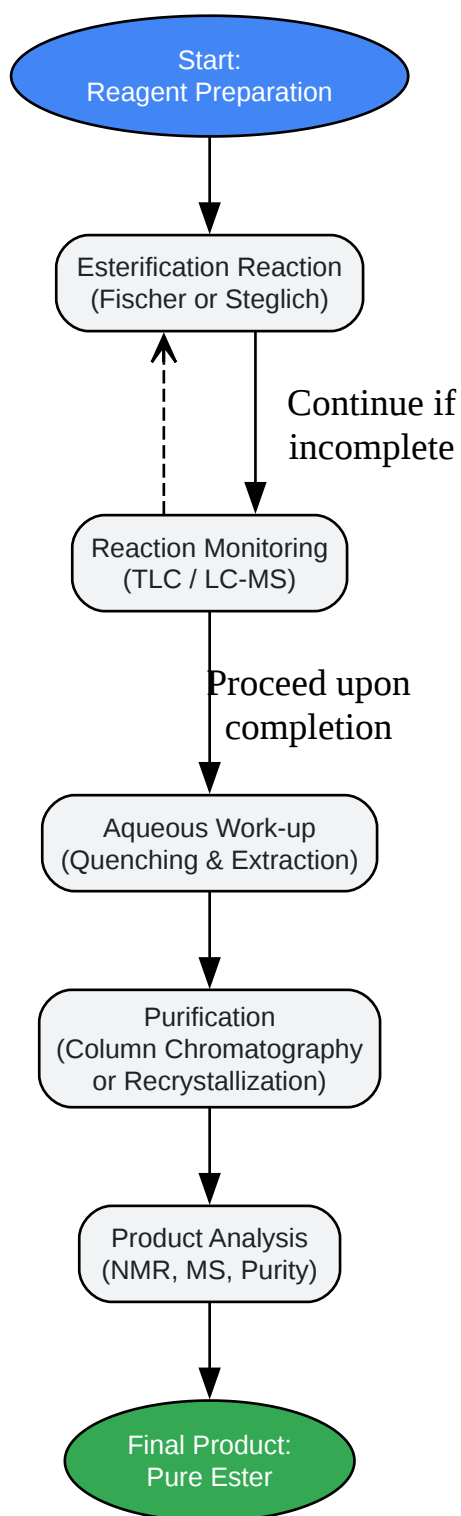

Diagram 2: General Experimental Workflow

[Click to download full resolution via product page](#)

Caption: Diagram 2: General Experimental Workflow.

## Protocol 1: Fischer-Speier Synthesis of Ethyl 5-Chloro-4-hydroxynicotinate

This protocol is adapted from a validated procedure for a structurally similar substrate.

### Materials & Reagents

Reagent/Material	Grade	Supplier Example
5-Chloro-4-hydroxynicotinic acid	≥97%	Sigma-Aldrich
Ethanol (Absolute, 200 proof)	ACS Grade	Fisher Scientific
Sulfuric Acid (H <sub>2</sub> SO <sub>4</sub> ), concentrated	ACS Grade, 95-98%	VWR
Sodium Bicarbonate (NaHCO <sub>3</sub> )	ACS Grade	EMD Millipore
Ethyl Acetate (EtOAc)	HPLC Grade	Thermo Scientific
Brine (Saturated NaCl solution)	-	Lab Prepared
Anhydrous Sodium Sulfate (Na <sub>2</sub> SO <sub>4</sub> )	ACS Grade	J.T.Baker
Round-bottom flask, condenser, heating mantle	-	Standard Labware

### Procedure

- **Reaction Setup:** To a 250 mL round-bottom flask, add **5-Chloro-4-hydroxynicotinic acid** (5.0 g, 28.8 mmol, 1.0 equiv).
- **Reagent Addition:** Add absolute ethanol (100 mL). Stir the resulting suspension. Carefully and slowly add concentrated sulfuric acid (1.6 mL, 30.2 mmol, 1.05 equiv) to the stirring suspension.
- **Reflux:** Equip the flask with a reflux condenser and heat the mixture to reflux (oil bath temperature ~95-100 °C). Maintain reflux for 6-8 hours. The reaction can be monitored by

Thin Layer Chromatography (TLC) until the starting material is consumed.

- **Cooling and Quenching:** After the reaction is complete, allow the mixture to cool to room temperature. Carefully pour the cooled reaction mixture into 200 mL of ice-cold water.
- **Neutralization:** Slowly add a saturated aqueous solution of sodium bicarbonate ( $\text{NaHCO}_3$ ) with stirring until the pH of the solution is neutral (pH ~7-8). Be cautious as  $\text{CO}_2$  evolution will cause foaming.
- **Extraction:** Transfer the neutralized mixture to a separatory funnel. Extract the aqueous layer with ethyl acetate (3 x 75 mL).
- **Washing and Drying:** Combine the organic extracts and wash with brine (1 x 50 mL). Dry the organic layer over anhydrous sodium sulfate ( $\text{Na}_2\text{SO}_4$ ).
- **Solvent Removal:** Filter off the drying agent and concentrate the filtrate under reduced pressure using a rotary evaporator to yield the crude product.
- **Purification:** The crude solid can be purified by recrystallization from an appropriate solvent system (e.g., ethanol/water or ethyl acetate/hexanes) or by flash column chromatography on silica gel to afford the pure ethyl 5-chloro-4-hydroxynicotinate.

## Protocol 2: Steglich Synthesis of a Generic 5-Chloro-4-hydroxynicotinate Ester

This protocol provides a general framework for a mild, room-temperature esterification.

Materials & Reagents

Reagent/Material	Grade	Supplier Example
5-Chloro-4-hydroxynicotinic acid	≥97%	Sigma-Aldrich
Alcohol (R-OH)	Anhydrous	Acros Organics
N,N'-Dicyclohexylcarbodiimide (DCC)	≥99%	TCI America
4-Dimethylaminopyridine (DMAP)	≥99%	Alfa Aesar
Dichloromethane (DCM), anhydrous	DriSolv®	EMD Millipore
Hydrochloric Acid (HCl), 1M solution	-	Lab Prepared
Saturated Sodium Bicarbonate (NaHCO <sub>3</sub> )	-	Lab Prepared
Anhydrous Magnesium Sulfate (MgSO <sub>4</sub> )	ACS Grade	Fisher Scientific

### Reaction Parameters

Parameter	Value
Temperature	0 °C to Room Temperature (~23 °C)
Reaction Time	4 - 18 hours
Solvent	Anhydrous Dichloromethane (DCM)
Stoichiometry	Acid:Alcohol:DCC:DMAP
	1.0 : 1.2 : 1.1 : 0.1 equiv.

### Procedure

- **Reaction Setup:** To a flame-dried round-bottom flask under an inert atmosphere (Nitrogen or Argon), add **5-Chloro-4-hydroxynicotinic acid** (1.0 equiv), the desired alcohol (1.2 equiv), and 4-DMAP (0.1 equiv).
- **Solvent Addition:** Dissolve the components in anhydrous dichloromethane (DCM), using approximately 10-15 mL of solvent per gram of the limiting reagent.
- **Initiation:** Cool the flask to 0 °C in an ice bath. Add a solution of DCC (1.1 equiv) in a minimal amount of anhydrous DCM dropwise to the stirring reaction mixture.
- **Reaction:** Allow the reaction to slowly warm to room temperature and stir for 4-18 hours. The progress is monitored by TLC. A white precipitate of dicyclohexylurea (DCU) will form as the reaction proceeds. [9]5. **Work-up - Filtration:** Upon completion, filter the reaction mixture through a pad of Celite® to remove the precipitated DCU. Wash the filter cake with a small amount of DCM.
- **Work-up - Washing:** Transfer the filtrate to a separatory funnel. Wash sequentially with 1M HCl (2 x volume), saturated NaHCO<sub>3</sub> solution (2 x volume), and brine (1 x volume).
- **Drying and Concentration:** Dry the organic layer over anhydrous magnesium sulfate (MgSO<sub>4</sub>), filter, and concentrate under reduced pressure.
- **Purification:** Purify the resulting crude residue by flash column chromatography on silica gel using an appropriate eluent system (e.g., a gradient of ethyl acetate in hexanes) to isolate the pure ester product.

## Safety and Troubleshooting

- **Safety:** Always work in a well-ventilated fume hood. Wear appropriate personal protective equipment (PPE), including safety glasses, lab coat, and gloves.
  - DCC is a potent skin sensitizer and should be handled with extreme care.
  - Concentrated H<sub>2</sub>SO<sub>4</sub> is highly corrosive. Add it slowly and carefully to ethanol to manage the exothermic reaction.
  - DMAP is toxic and should be handled with caution.

- Troubleshooting:
  - Low Yield (Fischer): Ensure water is effectively excluded or removed. The reaction is an equilibrium; using a large excess of alcohol or a Dean-Stark trap can improve yields. [1][4]
  - \* Low Yield (Steglich): Ensure all reagents and solvents are anhydrous, as water will consume the DCC. If the reaction is slow, a slight increase in the amount of DMAP may be beneficial.
  - Side Reaction (Steglich): A potential side reaction is the formation of an N-acylurea byproduct, which is suppressed by the DMAP catalyst. [9] If this is observed, ensure DMAP is present and active.

## References

- Fiveable. (2025, August 15). Steglich Esterification Definition. Fiveable.
- Wikipedia. (n.d.). Mitsunobu reaction.
- Hughes, D. L., Reamer, R. A., Bergan, J. J., & Grabowski, E. J. J. (1996). The Effect of Acid Strength on the Mitsunobu Esterification Reaction: Carboxyl vs Hydroxyl Reactivity. The Journal of Organic Chemistry. ACS Publications.
- Khmel'nitsky, Y. L., Mozhaev, V. V., Belova, A. B., Sergeeva, M. V., & Martinek, K. (n.d.). The Mitsunobu 1-O-esterification of 1-hydroxy-3-phenyl-1H-quinoxalin-2-one 4-oxide. Heterocycles.
- McCarthy, N., & McCarthy, T. D. (n.d.). Mechanism of the Mitsunobu Reaction: An Ongoing Mystery. The Journal of Organic Chemistry. NIH.
- Tokyo Chemical Industry. (n.d.). Mitsunobu Reaction. TCI Chemicals.
- Organic Chemistry Portal. (n.d.). Steglich Esterification.
- Wikipedia. (n.d.). Steglich esterification.
- Parveen, S., Kaur, N., & Kumar, V. (2023, December 9). Steglich esterification: A versatile synthetic approach toward the synthesis of natural products, their analogues/derivatives. Results in Chemistry. NIH.
- OrgoSolver. (n.d.). Carboxylic Acids + Alcohols → Esters (Fischer Esterification).
- Wikipedia. (n.d.). Fischer–Speier esterification.
- Chemistry LibreTexts. (2023, January 22). Fischer Esterification.
- Master Organic Chemistry. (2022, November 16). Fischer Esterification - Carboxylic Acid to Ester Under Acidic Conditions.
- Thomson, R. J., & Simmons, E. M. (2020, March 8). From 5-Hydroxynicotinic Acid to Nitrogenous (4+3)-Cycloadducts. Organic Syntheses.
- Chemistry Steps. (2021, November 18). Fischer Esterification.

- Organic Chemistry Portal. (n.d.). Fischer Esterification.
- Clark, J. (n.d.). The mechanism for the esterification reaction. Chemguide.
- BenchChem. (n.d.). Application Note and Protocols: Synthesis of Isonicotinate Esters from Isonicotinic Acid.
- OperaChem. (2024, January 5). Fischer Esterification-Typical Procedures.
- YouTube. (2016, December 27). Fischer Esterification Reaction Mechanism - Carboxylic Acid Derivatives.
- Nielsen, O., & Larsen, C. (n.d.). A Simple Method for Synthesis of Active Esters of Isonicotinic and Picolinic Acids. Molecules. NIH.

### Need Custom Synthesis?

BenchChem offers custom synthesis for rare earth carbides and specific isotopic labeling.

Email: [info@benchchem.com](mailto:info@benchchem.com) or [Request Quote Online](#).

## Sources

1. Fischer–Speier esterification - Wikipedia [[en.wikipedia.org](https://en.wikipedia.org)]
  2. [chem.libretexts.org](https://chem.libretexts.org) [[chem.libretexts.org](https://chem.libretexts.org)]
  3. Fischer Esterification [[organic-chemistry.org](https://organic-chemistry.org)]
  4. [orgosolver.com](https://orgosolver.com) [[orgosolver.com](https://orgosolver.com)]
  5. [masterorganicchemistry.com](https://masterorganicchemistry.com) [[masterorganicchemistry.com](https://masterorganicchemistry.com)]
  6. Fischer Esterification - Chemistry Steps [[chemistrysteps.com](https://chemistrysteps.com)]
  7. [chemguide.co.uk](https://chemguide.co.uk) [[chemguide.co.uk](https://chemguide.co.uk)]
  8. Steglich Esterification [[organic-chemistry.org](https://organic-chemistry.org)]
  9. Steglich esterification - Wikipedia [[en.wikipedia.org](https://en.wikipedia.org)]
  10. [fiveable.me](https://fiveable.me) [[fiveable.me](https://fiveable.me)]
  11. Steglich esterification: A versatile synthetic approach toward the synthesis of natural products, their analogues/derivatives - PMC [[pmc.ncbi.nlm.nih.gov](https://pmc.ncbi.nlm.nih.gov)]
- To cite this document: BenchChem. [Application Note & Protocols: Strategic Esterification of 5-Chloro-4-hydroxynicotinic Acid]. BenchChem, [2026]. [Online PDF]. Available at: [<https://www.benchchem.com/product/b1457750/docs#application-note-protocols-strategic-esterification-of-5-chloro-4-hydroxynicotinic-acid>]

**Disclaimer & Data Validity:**

The information provided in this document is for Research Use Only (RUO) and is strictly not intended for diagnostic or therapeutic procedures. While BenchChem strives to provide accurate protocols, we make no warranties, express or implied, regarding the fitness of this product for every specific experimental setup.

**Technical Support:** The protocols provided are for reference purposes. Unsure if this reagent suits your experiment?

**Need Industrial/Bulk Grade?** [Request Custom Synthesis Quote](#)

## BenchChem

Our mission is to be the trusted global source of essential and advanced chemicals, empowering scientists and researchers to drive progress in science and industry.

### Contact

Address: 3281 E Guasti Rd

Ontario, CA 91761, United States

Phone: (601) 213-4426

Email: [info@benchchem.com](mailto:info@benchchem.com)

[Contact our Ph.D. Support Team for a compatibility check](#)