

An In-Depth Technical Guide to the Copper-Gallium (Cu-Ga) Alloy System

Author: BenchChem Technical Support Team. **Date:** May 2026

Compound of Interest

Compound Name: *Copper;gallium*

Cat. No.: *B14561579*

[Get Quote](#)

Introduction

The study of binary alloy systems is fundamental to materials science and engineering, providing the foundational knowledge for the development of novel materials with tailored properties. Among these, the Copper-Gallium (Cu-Ga) system holds significant scientific and technological importance. Its alloys are integral to advanced applications ranging from dental amalgams and low-temperature solders to critical components in high-efficiency thin-film solar cells.^{[1][2]} A thorough understanding of the Cu-Ga phase diagram is therefore essential for researchers and engineers seeking to control the microstructure and, consequently, the performance of these materials.

This guide provides a detailed analysis of the Cu-Ga phase diagram, grounded in thermodynamic principles. It delves into the various intermetallic phases, their crystal structures, and the invariant reactions that govern phase transformations. Furthermore, it outlines field-proven experimental methodologies for the synthesis and characterization of these alloys, linking experimental choices to the fundamental principles of materials science.

Detailed Analysis of the Cu-Ga Phase Diagram

The Cu-Ga phase diagram is characterized by a complex series of intermetallic compounds and invariant reactions.[3] A thermodynamic assessment of the system reveals multiple stable and metastable phases, the formation of which is highly dependent on composition and temperature.[4]

Key Intermetallic Phases

The Cu-Ga system features several key intermetallic phases, each with a distinct crystal structure and composition range. The precise identification of these phases is critical, as their presence dictates the alloy's properties. Notable phases include CuGa_2 , which is stable at lower temperatures, and the γ -brass type structures (γ , γ_1 , γ_2 , γ_3) related to Cu_9Ga_4 , which are stable at higher temperatures.[4][5][6]

The causality behind the formation of these ordered intermetallic compounds lies in the strong orbital hybridization between the 3d electrons of copper and the d electrons of gallium. This interaction leads to a significant negative enthalpy of formation, which reduces the Gibbs free energy and promotes the transition from a disordered solid solution to a more stable, ordered intermetallic structure.[7]

Phase	Formula	Crystal System	Space Group	Pearson Symbol
θ	CuGa_2	Tetragonal	P4/nmm	tP6
γ	Cu_9Ga_4	Cubic	F-43m	cF52
γ_1	Cu_9Ga_4	Cubic	P-43m	cP52
γ_2	Cu_9Ga_4	Cubic	I-43m	cI52
γ_3	Cu_9Ga_4	Cubic	P-43m	cP52
ζ	$\sim\text{Cu}_7\text{Ga}_3$	Hexagonal	P6 ₃ /mmc	hP2
β	$\sim\text{Cu}_3\text{Ga}$	Body-Centered Cubic	Fm-3m	cF4
α -Cu	(Cu, Ga)	Face-Centered Cubic	Fm-3m	cF4

Table 1: Crystallographic data for major phases in the Cu-Ga system. Data compiled from various crystallographic and thermodynamic assessments.[4][5][7][8]

Invariant Reactions

Invariant reactions are transformations where three phases are in equilibrium, occurring at a specific temperature and composition. These points on the phase diagram are critical as they define the boundaries for processing and heat treatment. The Cu-Ga system exhibits several peritectic reactions, which can make the synthesis of single-phase materials challenging.[3] For instance, the θ -CuGa₂ phase is formed through a series of peritectic reactions, making its synthesis via equilibrium cooling difficult.[3]

Reaction Type	Temperature (°C)	Composition (at. % Ga)	Reaction
Peritectic	915	~18	$L + \alpha \leftrightarrow \beta$
Peritectic	838	~22	$L + \beta \leftrightarrow \gamma$
Peritectic	650	~30	$L + \gamma \leftrightarrow \zeta$
Peritectic	305	~68	$L + \epsilon \leftrightarrow \theta$
Eutectic	254	~97	$L \leftrightarrow \theta + (\text{Ga})$

Table 2: Key invariant reactions in the Cu-Ga system. These reactions dictate the solidification pathways and final microstructure of the alloys.[3][9]

Experimental Synthesis and Characterization

A robust understanding of the phase diagram is validated through systematic experimental work. The synthesis and characterization of Cu-Ga alloys require precise control over composition and thermal history.

Synthesis Protocol: Arc Melting

Arc melting is a standard and effective technique for producing high-purity, homogeneous binary alloys like Cu-Ga. The choice of this method is driven by its ability to achieve high temperatures rapidly in a controlled atmosphere, preventing oxidation of the constituent metals.

Step-by-Step Methodology:

- **Material Preparation:** High-purity copper (99.99%) and gallium (99.99%) are weighed to the desired atomic percentages.
- **Chamber Purging:** The arc furnace chamber is evacuated to a high vacuum ($< 10^{-5}$ mbar) and backfilled with high-purity argon gas. This process is repeated multiple times to minimize residual oxygen and nitrogen.
- **Melting:** A high current is passed through a non-consumable tungsten electrode, creating an arc that melts the raw materials on a water-cooled copper hearth.
- **Homogenization:** The resulting alloy "button" is flipped and re-melted several times (typically 4-5) to ensure chemical homogeneity. The water-cooled hearth provides a rapid solidification rate, which helps to suppress large-scale segregation.
- **Annealing (Optional):** For achieving equilibrium phases, the as-cast ingot is sealed in an evacuated quartz tube and annealed at a specific temperature, followed by quenching or slow cooling depending on the desired microstructure.

Characterization Workflow

A multi-technique approach is essential for a comprehensive analysis of the synthesized alloys. Each technique provides complementary information, creating a self-validating system for phase identification and microstructural analysis.

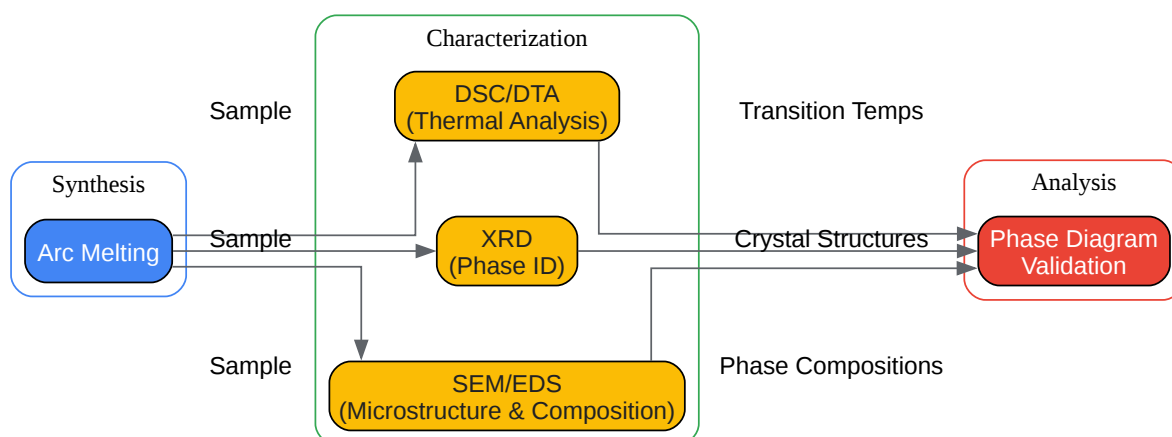

[Click to download full resolution via product page](#)

Caption: Experimental workflow for Cu-Ga alloy characterization.

1. Differential Scanning Calorimetry (DSC):

- Principle: DSC is the primary tool for identifying the temperatures of invariant reactions (e.g., melting, peritectic, eutectic). It measures the difference in heat flow between a sample and a reference as a function of temperature. Endothermic or exothermic peaks correspond to phase transformations.
- Protocol:
 - A small, representative sample (5-10 mg) is sealed in an aluminum or graphite pan.
 - The sample is heated at a controlled rate (e.g., 10°C/min) under an inert atmosphere (e.g., Argon).
 - The resulting thermogram is analyzed to determine the onset and peak temperatures of thermal events, which are then compared to the established phase diagram.[4]

2. X-Ray Diffraction (XRD):

- Principle: XRD is the definitive technique for identifying the crystal structures of the phases present in the alloy. By analyzing the diffraction pattern of a monochromatic X-ray beam interacting with the sample, the crystallographic planes can be identified and matched to known structures.
- Protocol:
 - A flat, polished surface of the alloy is prepared.
 - The sample is mounted in a diffractometer.
 - A θ - 2θ scan is performed over a relevant angular range (e.g., 20-100°).
 - The resulting diffraction peaks are matched with database entries (e.g., from the International Centre for Diffraction Data) to confirm the presence of phases like α -Cu, θ -CuGa₂, or γ -Cu₉Ga₄.^[10]

3. Scanning Electron Microscopy (SEM) with Energy Dispersive X-ray Spectroscopy (EDS):

- Principle: SEM provides high-resolution images of the alloy's microstructure, revealing the morphology, distribution, and size of different phases. When coupled with EDS, it allows for semi-quantitative elemental analysis of these distinct phases.
- Protocol:
 - The sample is mounted in an epoxy resin, ground, and polished to a mirror finish.
 - The polished surface may be etched with a suitable reagent to enhance phase contrast.
 - The sample is coated with a thin conductive layer (e.g., carbon) to prevent charging.
 - Backscattered Electron (BSE) imaging is used to differentiate phases based on atomic number contrast (heavier elements appear brighter).
 - EDS point analysis or elemental mapping is performed on each phase to determine its elemental composition, which is then correlated with the XRD results and the phase diagram.

Properties and Applications

The unique phases within the Cu-Ga system give rise to a range of useful properties.

- **Solar Cells:** Copper-gallium alloys are critical precursors for the production of Copper Indium Gallium Selenide (CIGS) thin-film solar cells.[1] The gallium content is a key factor in "bandgap engineering," allowing for the tuning of the solar cell's absorption spectrum to optimize efficiency.[1]
- **Low-Temperature Soldering:** Gallium's low melting point and its ability to readily form alloys with copper make it a candidate for specialized low-temperature soldering applications, particularly in heat-sensitive electronic components.[2][6]
- **Catalysis:** The ordered intermetallic structures of Cu-Ga alloys provide uniformly dispersed active sites, making them attractive for various catalytic applications. For example, CuGa₂ has shown high selectivity in the electrochemical reduction of CO₂ to methanol.[5][11]

Conclusion

The Copper-Gallium alloy system is a rich and complex field of study with direct relevance to modern technology. A deep understanding of its phase diagram, informed by thermodynamic principles and validated through rigorous experimental characterization, is paramount for the successful design and application of these materials. The interplay between the numerous intermetallic phases and the resulting material properties underscores the importance of precise compositional and microstructural control. Future research will likely focus on leveraging the unique properties of these intermetallic compounds for novel applications in sustainable energy and advanced electronics.

References

- Earth Rarest. (n.d.). CuGa Alloy: Critical Material for Renewable Energy. Retrieved from [\[Link\]](#)
- Bagchi, S., et al. (2022). Crystal structure of Cu–Ga-based intermetallics. ResearchGate. Retrieved from [\[Link\]](#)

- Royal Society of Chemistry. (2025). Recent advances in Cu-based intermetallics: structures, syntheses, and electrocatalytic applications. RSC Publishing. Retrieved from [\[Link\]](#)
- ATT Advanced Elemental Materials Co., Ltd. (n.d.). Copper Gallium Alloy. Retrieved from [\[Link\]](#)
- Li, M., et al. (2012). A thermodynamic assessment of the copper–gallium system. ResearchGate. Retrieved from [\[Link\]](#)
- Li, M., et al. (2012). Cu–Ga phase diagram calculated with the model used in the present work. ResearchGate. Retrieved from [\[Link\]](#)
- Wiley-VCH. (2022). a) Crystal structure of Cu–Ga-based intermetallic. b) FE for each.... ResearchGate. Retrieved from [\[Link\]](#)
- ASM International. (n.d.). Equilibrium diagram of the Cu–Ga system. ResearchGate. Retrieved from [\[Link\]](#)
- Shavorskiy, A., et al. (2023). Interaction of Gallium with a Copper Surface: Surface Alloying and Formation of Ordered Structures. ACS Publications. Retrieved from [\[Link\]](#)
- Bykov, V.A., et al. (2014). Thermal Expansion of Cu-Ga-Sn Alloys. Scientific.Net. Retrieved from [\[Link\]](#)
- National Institutes of Health. (2023). Interaction of Gallium with a Copper Surface: Surface Alloying and Formation of Ordered Structures. Retrieved from [\[Link\]](#)
- ResearchGate. (n.d.). Crystal structures of the phases in the Cu-Ga system. Retrieved from [\[Link\]](#)
- ResearchGate. (2020). Thermal Properties of CuGa₂ Phase in Inert Atmosphere. Retrieved from [\[Link\]](#)
- Materials Project. (n.d.). mp-1077001: GaCu₂ (Orthorhombic, Imma, 74). Retrieved from [\[Link\]](#)

- Shavorskiy, A., et al. (2023). Interaction of Gallium with a Copper Surface: Surface Alloying and Formation of Ordered Structures. Semantic Scholar. Retrieved from [[Link](#)]
- Liang, S.M., & Chang, Y.A. (2011). Thermodynamic descriptions of the Cu–Zn system. Journal of Materials Research. Retrieved from [[Link](#)]
- University of Tennessee. (n.d.). Phase Diagrams Invariant Reactions. Retrieved from [[Link](#)]
- Kim, B., et al. (2023). A Study on the Interfacial Reactions between Gallium and Cu/Ni/Au(Pd) Multilayer Metallization. MDPI. Retrieved from [[Link](#)]

Need Custom Synthesis?

BenchChem offers custom synthesis for rare earth carbides and specific isotopic labeling.

Email: info@benchchem.com or [Request Quote Online](#).

Sources

- [1. earthrarest.com \[earthrarest.com\]](#)
- [2. Interaction of Gallium with a Copper Surface: Surface Alloying and Formation of Ordered Structures - PMC \[pmc.ncbi.nlm.nih.gov\]](#)
- [3. researchgate.net \[researchgate.net\]](#)
- [4. researchgate.net \[researchgate.net\]](#)
- [5. researchgate.net \[researchgate.net\]](#)
- [6. mdpi.com \[mdpi.com\]](#)
- [7. Recent advances in Cu-based intermetallics: structures, syntheses, and electrocatalytic applications - Journal of Materials Chemistry A \(RSC Publishing\) DOI:10.1039/D5TA02448J \[pubs.rsc.org\]](#)
- [8. researchgate.net \[researchgate.net\]](#)
- [9. princeton.edu \[princeton.edu\]](#)
- [10. Thermal Expansion of Cu-Ga-Sn Alloys | Scientific.Net \[scientific.net\]](#)
- [11. researchgate.net \[researchgate.net\]](#)

- To cite this document: BenchChem. [An In-Depth Technical Guide to the Copper-Gallium (Cu-Ga) Alloy System]. BenchChem, [2026]. [Online PDF]. Available at: [<https://www.benchchem.com/product/b14561579/docs#an-in-depth-technical-guide-to-the-copper-gallium-cu-ga-alloy-system>]

Disclaimer & Data Validity:

The information provided in this document is for Research Use Only (RUO) and is strictly not intended for diagnostic or therapeutic procedures. While BenchChem strives to provide accurate protocols, we make no warranties, express or implied, regarding the fitness of this product for every specific experimental setup.

Technical Support: The protocols provided are for reference purposes. Unsure if this reagent suits your experiment?

Need Industrial/Bulk Grade? [Request Custom Synthesis Quote](#)

BenchChem

Our mission is to be the trusted global source of essential and advanced chemicals, empowering scientists and researchers to drive progress in science and industry.

Contact

Address: 3281 E Guasti Rd
Ontario, CA 91761, United States
Phone: (601) 213-4426
Email: info@benchchem.com

[Contact our Ph.D. Support Team for a compatibility check](#)