

# Introduction: The Significance of Thienopyrroledione-Based Polymers

**Author:** BenchChem Technical Support Team. **Date:** May 2026

## Compound of Interest

Compound Name:	5-Octyl-4H-thieno[3,4-c]pyrrole-4,6(5H)-dione
CAS No.:	773881-43-9
Cat. No.:	B1456462

[Get Quote](#)

The landscape of organic electronics is continually shaped by the development of novel conjugated polymers with tailored optoelectronic properties. Among the various electron-deficient building blocks available to polymer chemists, the thieno[3,4-c]pyrrole-4,6-dione (TPD) moiety has emerged as a particularly valuable component.<sup>[1]</sup> Its strong electron-withdrawing nature, stemming from the dicarbonyl groups of the imide ring, allows for the synthesis of low bandgap polymers when copolymerized with electron-rich units.<sup>[2][3]</sup> The introduction of an N-octyl side chain onto the TPD unit, creating **5-Octyl-4H-thieno[3,4-c]pyrrole-4,6(5H)-dione**, enhances the solubility of both the monomer and the resulting polymer in common organic solvents, which is a critical factor for solution-based processing of electronic devices.

TPD-based polymers typically exhibit deep frontier energy levels (HOMO/LUMO), which translates to high open-circuit voltages (Voc) in organic solar cells (OSCs).<sup>[1]</sup> Furthermore, their inherent planarity and strong intermolecular interactions facilitate good charge transport properties.<sup>[4][5]</sup> This guide provides a comprehensive overview of the primary synthetic methodologies for the polymerization of TPD-octyl derivatives, offering detailed protocols for both chemical and electrochemical approaches. It is designed for researchers in materials

science and professionals in drug development who may leverage these conductive polymers for applications ranging from organic photovoltaics to biosensors.

## Core Monomer: 1,3-Dibromo-5-octyl-4H-thieno[3,4-c]pyrrole-4,6(5H)-dione

The most common precursor for the synthesis of poly(TPD-octyl) through cross-coupling reactions is its dibrominated derivative. Bromination at the 1 and 3 positions of the thiophene ring provides the necessary reactive sites for polymerization.

- Chemical Name: 1,3-Dibromo-5-octyl-4H-thieno[3,4-c]pyrrole-4,6(5H)-dione
- CAS Number: 566939-58-0[6][7]
- Molecular Formula: C<sub>14</sub>H<sub>17</sub>Br<sub>2</sub>NO<sub>2</sub>S[6]
- Appearance: Typically a solid with a melting point between 105-109 °C.
- Key Role: Serves as the electron-accepting monomer in transition metal-catalyzed polymerization reactions. The bromine atoms act as leaving groups in coupling reactions like Stille or Suzuki.

## I. Chemical Polymerization Methodologies

Chemical polymerization offers excellent control over molecular weight and polymer structure, yielding well-defined materials suitable for high-performance devices. The two most prominent methods are Stille coupling and Direct (Hetero)arylation Polymerization (DArP).

### A. Stille Coupling Polymerization

Stille coupling is a robust and versatile palladium-catalyzed cross-coupling reaction between an organotin compound and an organohalide. For TPD-based polymers, this typically involves reacting the dibrominated TPD monomer with a distannylated comonomer (an electron-rich unit).[2]

Causality and Experimental Rationale: The choice of a palladium catalyst, such as Pd(PPh<sub>3</sub>)<sub>4</sub>, is critical as it effectively facilitates the catalytic cycle of oxidative addition, transmetalation, and

reductive elimination. The use of a high-boiling point solvent like toluene or DMF is necessary to achieve the required reaction temperatures for efficient coupling. Purification via Soxhlet extraction is a crucial step to remove catalyst residues and low molecular weight oligomers, which can be detrimental to device performance.

#### Protocol 1: Stille Coupling Synthesis of a TPD-based Copolymer

This protocol describes the synthesis of a copolymer of 1,3-Dibromo-5-octyl-TPD with a generic distannylated comonomer, such as 2,5-Bis(trimethylstannyl)thiophene.

#### Materials:

- 1,3-Dibromo-5-octyl-4H-thieno[3,4-c]pyrrole-4,6(5H)-dione (M1)
- 2,5-Bis(trimethylstannyl)thiophene (M2)
- Tetrakis(triphenylphosphine)palladium(0) [Pd(PPh<sub>3</sub>)<sub>4</sub>]
- Anhydrous Toluene and Dimethylformamide (DMF)
- Methanol, Hexane, Chloroform (for purification)
- Schlenk flask and line, condenser, magnetic stirrer, heating mantle
- Soxhlet extraction apparatus

#### Procedure:

- Inert Atmosphere: Assemble a Schlenk flask equipped with a condenser and magnetic stir bar. Flame-dry the glassware under vacuum and backfill with an inert gas (Argon or Nitrogen). This is crucial to prevent oxidation of the catalyst and organotin reagent.
- Reagent Addition: To the flask, add M1 (e.g., 0.50 mmol), M2 (0.50 mmol, 1.0 equiv), and the palladium catalyst Pd(PPh<sub>3</sub>)<sub>4</sub> (2-3 mol%).
- Solvent Addition: Add anhydrous toluene (e.g., 4 mL) and anhydrous DMF (e.g., 1 mL) via syringe. The solvent mixture helps to dissolve both the monomers and the catalyst.

- Polymerization Reaction: Heat the mixture to reflux (typically 110-120 °C) and stir vigorously for 24-48 hours under the inert atmosphere. The reaction progress can be monitored by taking small aliquots and analyzing them with GPC.
- Reaction Quenching & Precipitation: After cooling to room temperature, pour the dark reaction mixture into a beaker of vigorously stirring methanol (e.g., 200 mL). The crude polymer will precipitate as a solid.
- Purification:
  - Filter the crude polymer and wash it with methanol.
  - Dry the polymer and load it into a cellulose thimble for Soxhlet extraction.
  - Extract sequentially with methanol, hexane, and finally chloroform to remove impurities and fractionate the polymer.<sup>[2]</sup> The desired high molecular weight polymer is typically soluble in the chloroform fraction.
- Final Product: Recover the polymer from the chloroform fraction by rotary evaporation. Dry the final product under vacuum.

Table 1: Typical Stille Polymerization Parameters & Results

Parameter	Value/Condition	Rationale
Monomer Ratio	1:1 (Dihalide:Distannane)	Ensures high molecular weight polymer formation.
Catalyst Load	2-3 mol%	Balances reaction rate with cost and ease of removal.
Solvent	Toluene/DMF	High boiling point, good solubility for reagents.
Temperature	110-120 °C (Reflux)	Provides sufficient thermal energy for the catalytic cycle.
Reaction Time	24-48 hours	Allows the reaction to proceed to high conversion.
Typical Mw	10 - 70 kDa[2]	Indicates successful polymerization.
Typical PDI	2.0 - 3.5[2]	Typical for step-growth polymerization.

Diagram 1: Stille Coupling Polymerization Workflow

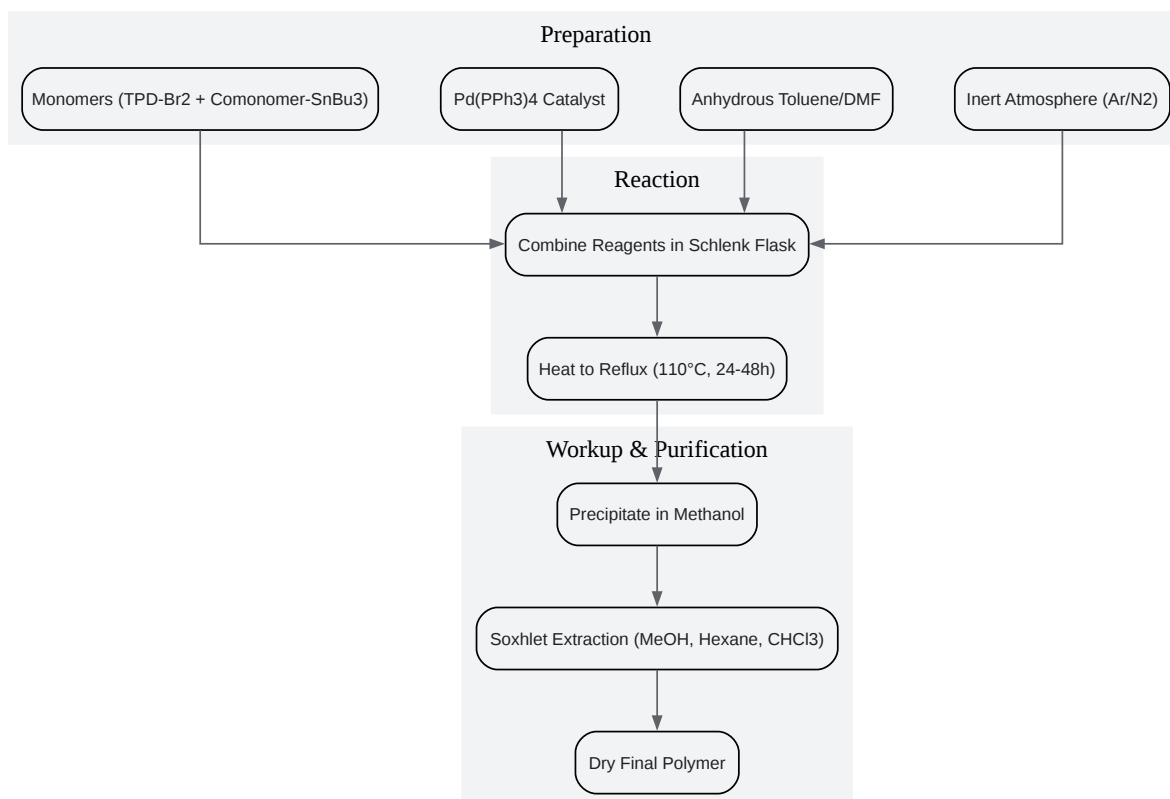

[Click to download full resolution via product page](#)

Caption: General workflow for Stille coupling polymerization.

## B. Direct (Hetero)arylation Polymerization (DARp)

DARp is an increasingly popular "green" alternative to traditional cross-coupling methods. It forms C-C bonds by coupling a C-H bond with a C-Halide bond, thus avoiding the need for toxic organotin or organoboron reagents.<sup>[5][8]</sup> For TPD polymers, this typically involves reacting the dibrominated TPD monomer with a comonomer possessing activated C-H bonds.

Causality and Experimental Rationale: This method simplifies synthesis by reducing preparatory steps for the monomers.[5] The catalyst system, often palladium acetate with a phosphine ligand and a base like potassium acetate, is designed to activate the C-H bond. The choice of a polar aprotic solvent like DMF or DMAc is crucial for the base to function effectively. DArP can often lead to very high molecular weight polymers.[4]

#### Protocol 2: Direct Arylation Synthesis of a TPD-based Homopolymer

This protocol outlines the homopolymerization of a TPD monomer that has both a C-Br and an activatable C-H bond, or the copolymerization of TPD-Br<sub>2</sub> with a C-H activated comonomer. The example below is for a homopolymerization.

#### Materials:

- 1-Bromo-5-octyl-4H-thieno[3,4-c]pyrrole-4,6(5H)-dione (Monobrominated TPD)
- Palladium(II) Acetate [Pd(OAc)<sub>2</sub>]
- Triphenylphosphine (PPh<sub>3</sub>) or other suitable ligand
- Potassium Acetate (KOAc) or Pivalic Acid (PivOH) as an additive
- Anhydrous N,N-Dimethylacetamide (DMAc)
- Methanol, Acetone, Chloroform
- Schlenk tube/flask and line

#### Procedure:

- Inert Atmosphere & Reagent Loading: In a flame-dried Schlenk tube, add the monobrominated TPD monomer (e.g., 0.50 mmol), Pd(OAc)<sub>2</sub> (2-5 mol%), PPh<sub>3</sub> (4-10 mol%), and KOAc (2-3 equivalents).
- Solvent and Additive: Add anhydrous DMAc (to achieve a monomer concentration of ~0.1 M) and, if required, pivalic acid (30 mol%) which can aid in the C-H activation step.

- **Degassing:** Subject the mixture to several freeze-pump-thaw cycles to thoroughly remove dissolved oxygen, which can deactivate the catalyst.
- **Polymerization Reaction:** Place the sealed tube in a preheated oil bath at 100-120 °C and stir for 24-48 hours.
- **Precipitation and Washing:** After cooling, pour the viscous solution into methanol. Filter the resulting fibrous polymer. Wash the collected solid extensively with methanol and acetone to remove residual catalyst and monomer.
- **Purification:** The polymer can be further purified by Soxhlet extraction or reprecipitation (dissolving in a good solvent like chloroform and precipitating in a poor solvent like methanol).
- **Final Product:** Dry the purified polymer under high vacuum.

## II. Electrochemical Polymerization

Electropolymerization is a powerful technique for synthesizing conductive polymer films directly onto an electrode surface.<sup>[9]</sup> This method is particularly advantageous as it is fast, occurs under ambient conditions, and allows for precise control over film thickness by modulating the charge passed during synthesis.<sup>[10]</sup>

**Causality and Experimental Rationale:** The process involves the electrochemical oxidation of the monomer at an applied potential. This oxidation generates radical cations which then couple to form dimers, oligomers, and ultimately, a polymer film that precipitates onto the electrode surface.<sup>[10]</sup> A three-electrode setup is used to accurately control the potential of the working electrode where the film grows. The supporting electrolyte is essential to ensure conductivity of the solution. The choice of applied voltage is critical; a potential just above the monomer's oxidation potential is typically used. Higher voltages can speed up film growth but may lead to defects or over-oxidation of the polymer.<sup>[9]</sup>

Diagram 2: Electrochemical Polymerization Setup

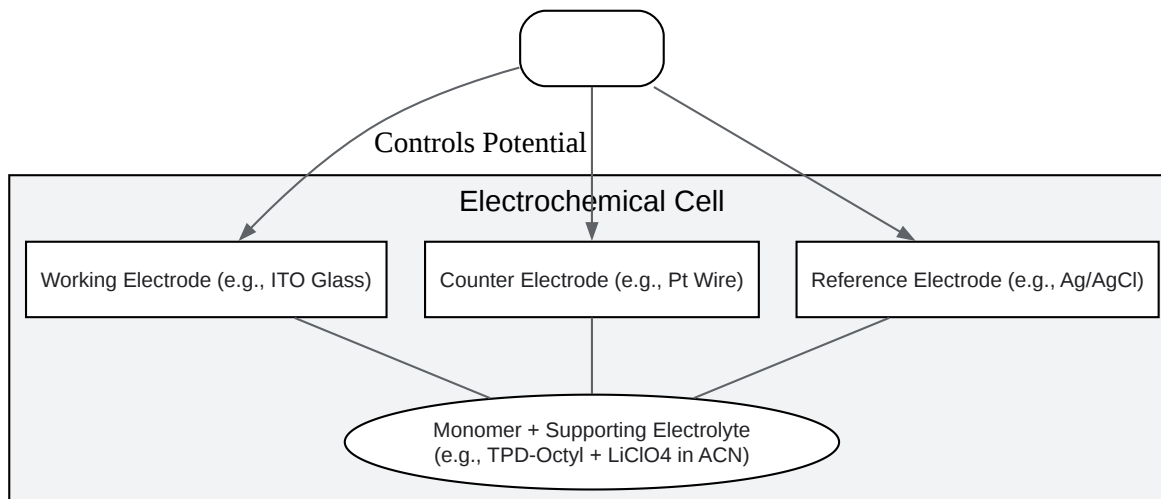

[Click to download full resolution via product page](#)

Caption: Schematic of a three-electrode cell for electropolymerization.

### Protocol 3: Potentiostatic Electropolymerization of TPD-Octyl

This protocol describes the deposition of a poly(TPD-octyl) film onto an Indium Tin Oxide (ITO) coated glass slide.

Materials:

- **5-Octyl-4H-thieno[3,4-c]pyrrole-4,6(5H)-dione** (non-brominated)
- Supporting Electrolyte: Lithium Perchlorate ( $\text{LiClO}_4$ ) or Tetrabutylammonium Hexafluorophosphate ( $\text{TBAPF}_6$ )
- Solvent: Anhydrous Acetonitrile (ACN) or Dichloromethane (DCM)
- Three-electrode electrochemical cell
- Working Electrode (WE): ITO-coated glass slide
- Counter Electrode (CE): Platinum wire or foil

- Reference Electrode (RE): Ag/AgCl or Saturated Calomel Electrode (SCE)
- Potentiostat

Procedure:

- **Electrode Preparation:** Clean the ITO slide by sonicating sequentially in detergent, deionized water, acetone, and isopropanol. Dry it under a stream of nitrogen.
- **Electrolyte Solution:** Prepare a solution containing the TPD-octyl monomer (e.g., 10 mM) and the supporting electrolyte (e.g., 0.1 M) in the chosen anhydrous solvent.
- **Cell Assembly:** Assemble the three-electrode cell with the ITO slide as the working electrode, the platinum wire as the counter electrode, and the Ag/AgCl electrode as the reference. Ensure the active surface of the ITO is immersed in the solution.
- **Degassing:** Bubble an inert gas (Argon) through the solution for 15-20 minutes to remove dissolved oxygen. Maintain a gentle argon blanket over the solution during the experiment.
- **Determining Oxidation Potential (Optional but Recommended):** Run a cyclic voltammogram (CV) scan (e.g., from 0 V to +1.6 V vs. Ag/AgCl) to determine the onset potential of monomer oxidation.
- **Potentiostatic Deposition:** Apply a constant potential just above the monomer's oxidation potential (e.g., +1.4 V vs. Ag/AgCl) for a set duration (e.g., 60-300 seconds). A colored polymer film will be observed growing on the ITO surface. The film thickness is proportional to the total charge passed.
- **Post-Deposition Cleaning:** After deposition, carefully remove the polymer-coated electrode from the cell. Rinse it thoroughly with the pure solvent (ACN or DCM) to remove unreacted monomer and electrolyte.
- **Drying:** Dry the film gently under a nitrogen stream or in a vacuum oven at a low temperature.

### III. Polymer Characterization

Once synthesized, the polymer must be thoroughly characterized to understand its structure and properties, which are critical for its application.

Table 2: Key Characterization Techniques and Insights

Technique	Property Measured	Insights Gained
<sup>1</sup> H NMR Spectroscopy	Chemical Environment of Protons	Confirms the polymer's chemical structure and purity.
Gel Permeation Chromatography (GPC)	Molecular Weight (M <sub>w</sub> , M <sub>n</sub> ) & Polydispersity (PDI)	Determines the average polymer chain length and its distribution.[2]
Thermogravimetric Analysis (TGA)	Weight Loss vs. Temperature	Assesses the thermal stability of the polymer, crucial for device fabrication and lifetime. [2]
UV-Vis Spectroscopy	Light Absorption Spectrum	Determines the optical bandgap (E <sub>g</sub> ) and identifies the maximum absorption wavelength (λ <sub>max</sub> ).[4]
Cyclic Voltammetry (CV)	Oxidation & Reduction Potentials	Estimates the HOMO and LUMO energy levels, which are vital for predicting device performance.[4]

## IV. Applications in Organic Electronics

The unique electronic properties of poly(TPD-octyl) and its derivatives make them highly suitable for use as n-type (electron-accepting) or ambipolar semiconductors in various organic electronic devices.

- Organic Solar Cells (OSCs): TPD-based polymers are used as electron acceptors in all-polymer solar cells or as a component in donor-acceptor copolymers.[1] Their deep HOMO levels contribute to high Voc, and their broad absorption can improve light harvesting.[2][3]

- Organic Field-Effect Transistors (OFETs): The ordered packing and planarity of these polymers facilitate efficient charge transport, making them excellent candidates for the active channel material in OFETs, demonstrating good electron mobilities.[\[5\]](#)[\[8\]](#)

## References

- Liu, W. F., et al. (2015). New 5-Octyl-thieno[3,4-c]pyrrole-4,6-dione Based Polymers: Synthesis and Photovoltaic Properties. *Molecular Crystals and Liquid Crystals*, 610(1), 59-69. [\[Link\]](#)
- Leclerc, M., et al. (2011). Synthesis and characterization of 5-octylthieno[3,4-c]pyrrole-4,6-dione derivatives as new monomers for conjugated copolymers. *Organic Letters*, 13(1), 38-41. [\[Link\]](#)
- Elbarbary, A. A., et al. (2022). Polymers based on thieno[3,4-c]pyrrole-4,6-dione and pyromellitic diimide by CH–CH arylation reaction for high-performance thin-film transistors. *RSC Advances*, 12(49), 31180-31185. [\[Link\]](#)
- Nguyen, C. H. T., et al. (2022). Effect of Applied Voltage on the Electrochemical Copolymerization of Thiophene and Dithenopyrrole Derivatives. *Journal of Macromolecular Science, Part A*, 59(12), 875-882. [\[Link\]](#)
- Elbarbary, A. A., et al. (2022). Polymers based on thieno[3,4-c]pyrrole-4,6-dione and pyromellitic diimide by CH–CH arylation reaction for high-performance thin-film transistors. *RSC Advances*, 12, 31180. [\[Link\]](#)
- National Center for Biotechnology Information (2022). Polymers based on thieno[3,4-c]pyrrole-4,6-dione and pyromellitic diimide by CH–CH arylation reaction for high-performance thin-film transistors. *PubMed Central*. [\[Link\]](#)
- MOLBASE. 1,3-Dibromo-**5-octyl-4H-thieno[3,4-c]pyrrole-4,6(5H)-dione**. [\[Link\]](#)
- Sahu, D., et al. (2018). Synthesis and applications of thieno[3,4-c]pyrrole-4,6-dione based linear to star-burst novel D–A conjugated oligomers for organic photovoltaics. *Journal of Materials Science: Materials in Electronics*, 29, 15823–15834. [\[Link\]](#)

- Wang, J., et al. (2020). Thieno[3,4-c]pyrrole-4,6-dione-based conjugated polymers for organic solar cells. *Chemical Communications*, 56(68), 9749-9764. [[Link](#)]
- Najari, A., et al. (2022). Synthesis of thieno[3,4-c]pyrrole-4,6-dione-based small molecules for application in organic thin-film. *Journal of Chemical Research*, 46(11-12), 834-840. [[Link](#)]
- Peterson, M. (2016). Electrochemical Polymerization of Thiophene Derivatives attached to Lead Sulfide Nanoparticle. Winona State University. [[Link](#)]

### Need Custom Synthesis?

BenchChem offers custom synthesis for rare earth carbides and specific isotopic labeling.

Email: [info@benchchem.com](mailto:info@benchchem.com) or [Request Quote Online](#).

## Sources

- 1. Thieno[3,4-c]pyrrole-4,6-dione-based conjugated polymers for organic solar cells - *Chemical Communications* (RSC Publishing) [[pubs.rsc.org](https://pubs.rsc.org)]
- 2. [tandfonline.com](https://tandfonline.com) [[tandfonline.com](https://tandfonline.com)]
- 3. [scispace.com](https://scispace.com) [[scispace.com](https://scispace.com)]
- 4. [scholarworks.bwise.kr](https://scholarworks.bwise.kr) [[scholarworks.bwise.kr](https://scholarworks.bwise.kr)]
- 5. Polymers based on thieno[3,4-c]pyrrole-4,6-dione and pyromellitic diimide by CH–CH arylation reaction for high-performance thin-film transistors - *PMC* [[pmc.ncbi.nlm.nih.gov](https://pmc.ncbi.nlm.nih.gov)]
- 6. 1,3-Dibromo-5-octyl-4H-thieno[3,4-c]pyrrole-4,6(5H)-dione|566939-58-0 - *MOLBASE Encyclopedia* [[m.molbase.com](https://m.molbase.com)]
- 7. China 1,3-Dibromo-5-octyl-4H-thieno[3,4-c]pyrrole-4,6(5H)-dione CAS No.: 566939-58-0 Manufacturers - Free Sample - Alfa Chemical [[alfachemch.com](https://alfachemch.com)]
- 8. Polymers based on thieno[3,4-c]pyrrole-4,6-dione and pyromellitic diimide by CH–CH arylation reaction for high-performance thin-film transistors - *RSC Advances* (RSC Publishing) [[pubs.rsc.org](https://pubs.rsc.org)]
- 9. [scispace.com](https://scispace.com) [[scispace.com](https://scispace.com)]
- 10. [openriver.winona.edu](https://openriver.winona.edu) [[openriver.winona.edu](https://openriver.winona.edu)]
- To cite this document: BenchChem. [Introduction: The Significance of Thienopyrroledione-Based Polymers]. BenchChem, [2026]. [Online PDF]. Available at:

[\[https://www.benchchem.com/product/b1456462/docs#introduction-the-significance-of-thienopyrroledione-based-polymers\]](https://www.benchchem.com/product/b1456462/docs#introduction-the-significance-of-thienopyrroledione-based-polymers)

---

**Disclaimer & Data Validity:**

The information provided in this document is for Research Use Only (RUO) and is strictly not intended for diagnostic or therapeutic procedures. While BenchChem strives to provide accurate protocols, we make no warranties, express or implied, regarding the fitness of this product for every specific experimental setup.

**Technical Support:** The protocols provided are for reference purposes. Unsure if this reagent suits your experiment?

**Need Industrial/Bulk Grade?** [Request Custom Synthesis Quote](#)

## BenchChem

Our mission is to be the trusted global source of essential and advanced chemicals, empowering scientists and researchers to drive progress in science and industry.

### Contact

Address: 3281 E Guasti Rd  
Ontario, CA 91761, United States  
Phone: (601) 213-4426  
Email: [info@benchchem.com](mailto:info@benchchem.com)

[Contact our Ph.D. Support Team for a compatibility check](#)