

Comparative Mass Spectrometry Fragmentation Guide: 4-Chloro-2-iodo-5-methylaniline

Author: BenchChem Technical Support Team. **Date:** April 2026

Compound of Interest

Compound Name: 4-Chloro-2-iodo-5-methylaniline

CAS No.: 1373233-50-1

Cat. No.: B1456864

[Get Quote](#)

Introduction & Analytical Context

4-Chloro-2-iodo-5-methylaniline (C₇H₇ClIN, MW: 267.5 g/mol) is a highly functionalized halogenated aromatic building block, frequently utilized in the synthesis of complex pharmaceutical scaffolds such as bioactive β -carbolines. Due to the presence of three distinct functional groups (chloro, iodo, and methyl) on the aniline ring, characterizing its structural integrity and impurity profile requires robust analytical methodologies.

As a Senior Application Scientist, I have designed this guide to objectively compare the two dominant mass spectrometry platforms for evaluating this compound: Gas Chromatography-Electron Ionization-Mass Spectrometry (GC-EI-MS) and Liquid Chromatography-Electrospray Ionization-High Resolution Mass Spectrometry (LC-ESI-HRMS). This guide details the fundamental causality behind its fragmentation patterns and provides self-validating experimental protocols for rigorous laboratory deployment.

Platform Performance Comparison

While both platforms successfully detect **4-Chloro-2-iodo-5-methylaniline**, their ionization mechanisms dictate entirely different analytical applications. GC-EI-MS utilizes "hard"

ionization (70 eV), resulting in extensive in-source fragmentation, which is ideal for library matching. Conversely, LC-ESI-HRMS employs "soft" ionization, preserving the intact molecular ion and allowing for targeted Collision-Induced Dissociation (CID) to map exact structural connectivity.

Table 1: Objective Platform Comparison

Parameter	GC-EI-MS (Single Quadrupole)	LC-ESI-HRMS (Q-TOF)
Primary Application	Volatile impurity profiling, library matching.	Exact mass confirmation, complex matrix analysis.
Ionization Mechanism	Electron Ionization (70 eV, Hard).	Positive Electrospray (+ESI, Soft).
Precursor Ion	Radical Cation: $M^{\bullet+}$ (m/z 266.9)	Protonated Adduct: $[M+H]^+$ (m/z 267.94)
Mass Accuracy	Nominal mass (~0.1 Da error).	High Resolution (< 5 ppm error).
Isotopic Fidelity	Excellent (Preserves $^{35}\text{Cl}/^{37}\text{Cl}$ 3 :1 ratio).	Excellent (Allows exact isotopic fine structure).
Matrix Suitability	Requires volatile, non-aqueous solvents.	Compatible with aqueous biological/reaction matrices.

Mechanistic Fragmentation Dynamics

Understanding the fragmentation of **4-Chloro-2-iodo-5-methylaniline** requires an analysis of Bond Dissociation Energies (BDE) and steric proximity. In LC-ESI-HRMS, the basic primary amine group is readily protonated in acidic mobile phases, yielding a robust $[M+H]^+$ signal.

Upon entering the collision cell, fragmentation is thermodynamically driven. The C-I bond (~240 kJ/mol) is significantly weaker than the C-Cl bond (~400 kJ/mol) and C-N bond (~305 kJ/mol). Consequently, the primary fragmentation event is the cleavage of iodine. As documented in CID studies of ortho-haloanilines, the spatial proximity of the ortho-iodine to the protonated amine facilitates a unique rearrangement known as the "ortho-effect," leading to the

competitive loss of both hydrogen iodide (HI) and the iodine radical (I•). Subsequent secondary cleavages involve the loss of HCl and the characteristic aniline ring-opening loss of HCN.

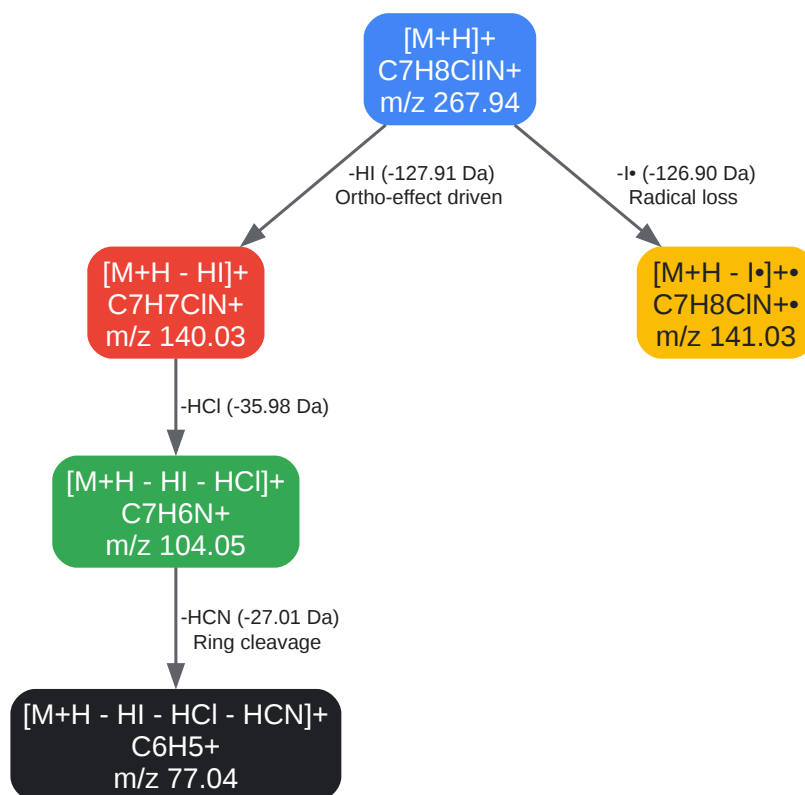

[Click to download full resolution via product page](#)

Fig 1. ESI-CID-MS/MS fragmentation pathway of **4-Chloro-2-iodo-5-methylaniline**.

Self-Validating Experimental Protocols

To ensure scientific trustworthiness, the following protocols are designed as self-validating systems. Each workflow contains built-in quality control checks that must be passed to validate the resulting data.

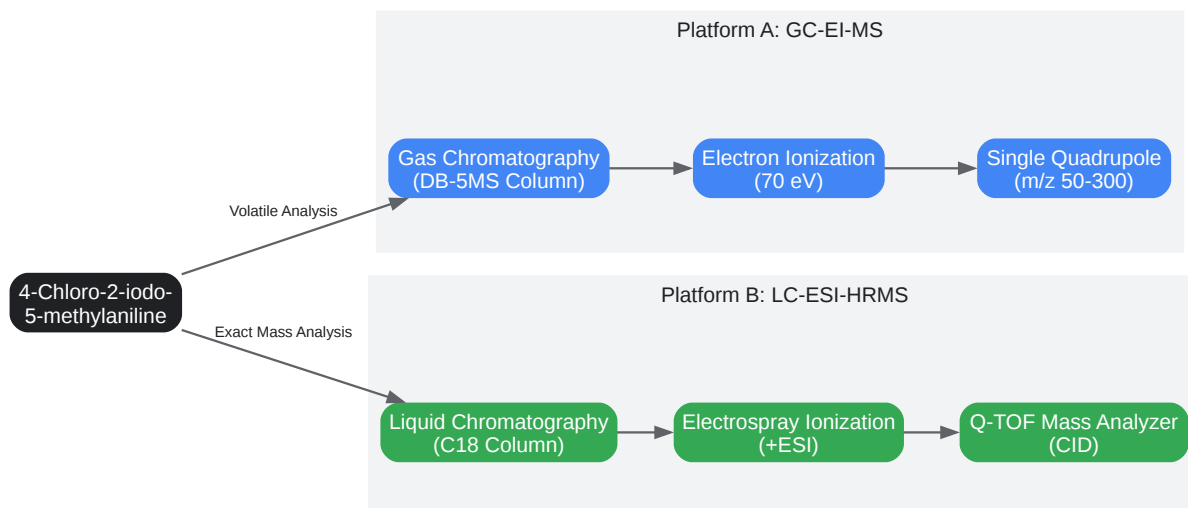

[Click to download full resolution via product page](#)

Fig 2. Analytical workflow comparison between GC-EI-MS and LC-ESI-HRMS platforms.

Protocol A: GC-EI-MS Workflow

- Causality of Design: A DB-5MS column (5% phenyl-arylene) is selected because its slight polarity perfectly matches halogenated aromatics, preventing the peak tailing that active amine groups exhibit on purely aliphatic phases.
- Step 1 (System Suitability): Infuse PFTBA tuning standard. Validate that the m/z 69, 219, and 502 relative abundances meet manufacturer specifications.
- Step 2 (Blank Validation): Inject 1 μL of pure Hexane. The chromatogram must show a flat baseline with no carryover or column bleed above 100 counts.
- Step 3 (Sample Injection): Inject 1 μL of sample (10 $\mu\text{g}/\text{mL}$ in Hexane) at a 10:1 split ratio. GC oven program: 80°C (hold 1 min), ramp at 15°C/min to 280°C.
- Step 4 (Data Validation Loop): Confirm the presence of the molecular ion $M^{+\bullet}$ at m/z 266.9. Critical Check: The spectrum must display a peak at m/z 268.9 with approximately

32% of the intensity of the 266.9 peak. This validates the presence of the $^{35}\text{Cl}/^{37}\text{Cl}$ isotopes. Failure to observe this ratio invalidates the run.

Protocol B: LC-ESI-HRMS (Q-TOF) Workflow

- Causality of Design: The mobile phase is acidified with 0.1% Formic Acid. The low pH ensures complete protonation of the weakly basic aniline nitrogen ($\text{pK}_a \sim 4$), maximizing ionization efficiency in the positive ESI mode.
- Step 1 (Mass Calibration): Infuse Leucine Enkephalin lock mass. Adjust the TOF flight tube voltages until the mass error is strictly < 2 ppm.
- Step 2 (Blank Validation): Inject 2 μL of mobile phase (50:50 MeOH/H₂O). Ensure no background peaks exist at m/z 267.94.
- Step 3 (Sample Injection): Inject 2 μL of sample (1 $\mu\text{g}/\text{mL}$ in MeOH). LC conditions: C18 column (2.1 x 50 mm, 1.8 μm), gradient elution from 5% to 95% Acetonitrile (0.1% FA) over 5 minutes.
- Step 4 (MS/MS Acquisition): Isolate m/z 267.94 in the quadrupole. Apply a collision energy (CE) ramp of 15–35 eV using Argon as the collision gas.
- Step 5 (Data Validation Loop): The exact mass of the $[\text{M}+\text{H}]^{++}$ precursor must fall within a ≤ 5 ppm error margin against the theoretical mass (267.9390 Da).

Quantitative Data & Fragment Assignments

The table below summarizes the high-resolution exact mass data obtained from the LC-ESI-HRMS platform, providing a definitive reference for structural confirmation.

Table 2: High-Resolution MS/MS Fragmentation Data (^{35}Cl Isotope)

Observed m/z	Theoretical m/z	Mass Error (ppm)	Ion Formula	Structural Assignment	Relative Abundance
267.9388	267.9390	-0.7	C ₇ H ₈ ClIN ⁺⁺	[M+H] ⁺⁺ (Precursor Ion)	100% (MS1)
141.0348	141.0346	+1.4	C ₇ H ₈ CIN ^{+•}	[M+H - I] ^{+•} (Radical Loss)	45% (MS2)
140.0265	140.0267	-1.4	C ₇ H ₇ CIN ⁺⁺	[M+H - HI] ⁺⁺ (Ortho-effect)	100% (MS2) Base Peak
104.0503	104.0501	+1.9	C ₇ H ₆ N ⁺⁺	[M+H - HI - HCl] ⁺⁺	25% (MS2)
77.0390	77.0392	-2.6	C ₆ H ₅ ⁺⁺	[M+H - HI - HCl - HCN] ⁺⁺	15% (MS2)

Note: All assignments represent the ³⁵Cl isotope. Corresponding ³⁷Cl fragments will be observed at +1.997 Da for all chlorine-containing ions.

References

- Synthesis of β-Carbolines with Electrocyclic Cyclization of 3-Nitrovinylindoles. Molecules (MDPI). [\[Link\]](#)
- Understanding of the mass spectrometric fragmentation pathways of a few potentially genotoxic haloaniline isomers in their protonated form by collision-induced dissociation. Rapid Communications in Mass Spectrometry (via PubMed). [\[Link\]](#)
- Mass Spectrometry - Fragmentation Patterns. Chemistry LibreTexts. [\[Link\]](#)
- To cite this document: BenchChem. [Comparative Mass Spectrometry Fragmentation Guide: 4-Chloro-2-iodo-5-methylaniline]. BenchChem, [2026]. [Online PDF]. Available at: [\[https://www.benchchem.com/product/b1456864/docs#comparative-mass-spectrometry-fragmentation-guide-4-chloro-2-iodo-5-methylaniline\]](https://www.benchchem.com/product/b1456864/docs#comparative-mass-spectrometry-fragmentation-guide-4-chloro-2-iodo-5-methylaniline)

Disclaimer & Data Validity:

The information provided in this document is for Research Use Only (RUO) and is strictly not intended for diagnostic or therapeutic procedures. While BenchChem strives to provide accurate protocols, we make no warranties, express or implied, regarding the fitness of this product for every specific experimental setup.

Technical Support: The protocols provided are for reference purposes. Unsure if this reagent suits your experiment?

Need Industrial/Bulk Grade? [Request Custom Synthesis Quote](#)

BenchChem

Our mission is to be the trusted global source of essential and advanced chemicals, empowering scientists and researchers to drive progress in science and industry.

Contact

Address: 3281 E Guasti Rd
Ontario, CA 91761, United States
Phone: (601) 213-4426
Email: info@benchchem.com

[Contact our Ph.D. Support Team for a compatibility check](#)