

# Technical Support Center: Optimization of Quinoline Synthesis

**Author:** BenchChem Technical Support Team. **Date:** May 2026

## Compound of Interest

Compound Name: *Methyl 5-bromo-4-chloro-8-methylquinoline-2-carboxylate*

CAS No.: *1133115-60-2*

Cat. No.: *B1454296*

[Get Quote](#)

Topic: Overcoming Low Conversion Rates & Side Reactions Audience: Medicinal Chemists, Process Chemists, and Academic Researchers

## Introduction: The Scaffold that Breaks Hearts

As a Senior Application Scientist, I often see the quinoline scaffold—ubiquitous in antimalarials (Chloroquine), anticancer agents (Camptothecin), and organic electronics—become a bottleneck in synthesis. Whether you are running a classical Skraup, a condensation-based Friedländer, or a modern Metal-Catalyzed cyclization, the failure modes are distinct but predictable.

This guide moves beyond textbook definitions to address the causality of failure: why your reaction turned to tar, why it stalled at 40% conversion, and how to force the thermodynamics in your favor.

## Module 1: The "Tar Pit" – Troubleshooting Skraup & Doebner-Miller

The Symptom: The reaction mixture turns into a viscous, black, intractable solid (tar) with <20% yield of the desired quinoline.

## Root Cause Analysis

The classical Skraup involves the in situ generation of acrolein (from glycerol).[1] Acrolein is a highly reactive

-unsaturated aldehyde.[1]

- The Trap: Under harsh acidic conditions, acrolein polymerizes faster than it undergoes the Michael addition with aniline.
- The Thermal Runaway: The reaction is violently exothermic. Once the "induction period" ends, the temperature spikes, favoring chaotic polymerization over controlled cyclization.

## Troubleshooting Q&A

Q: My Skraup reaction is violent and yields mostly tar. How do I control the exotherm? A: You must decouple the acrolein generation from the cyclization.

- The Moderator Solution: Add Ferrous Sulfate ( $\text{FeSO}_4$ ).[2][3] It acts as an oxygen carrier and a moderator, taming the violence of the reaction.
- Protocol Adjustment: Do not mix everything cold and heat rapidly. Use a Two-Stage Temperature Profile:
  - Hold at 145–150°C to initiate controlled acrolein release.
  - Ramp to 160–170°C only after the exotherm subsides to drive the final aromatization.

Q: I am using an electron-deficient aniline (e.g., nitroaniline), and the reaction fails. Why? A: The Skraup relies on the nucleophilicity of the amine for the initial Michael addition. Electron-withdrawing groups (EWGs) deactivate the ring.

- The Fix: Switch to the Combes Synthesis or use pre-formed enones. If you must use Skraup, add Boric Acid as a promoter, or use a sulfolane solvent system to allow higher temperatures without charring.

## Visualizing the Failure Mode

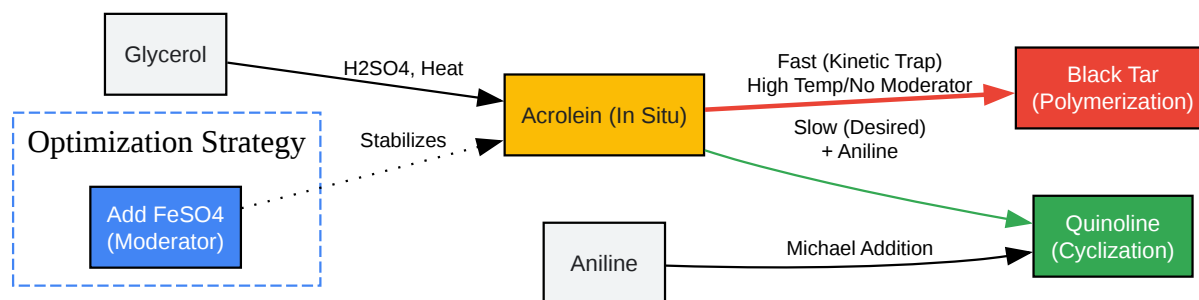

[Click to download full resolution via product page](#)

Figure 1: The Kinetic Trap in Skraup Synthesis. Without moderation, acrolein polymerization outcompetes quinoline formation.

## Module 2: The Stalled Condensation – Friedländer & Combes

The Symptom: Clean reaction profile, but conversion stalls at 50-60%. Adding more catalyst does not help.

### Root Cause Analysis

The Friedländer synthesis is a condensation between a 2-aminoaryl ketone and an -methylene ketone.[4]

- **Reversibility:** The initial imine formation is an equilibrium process. Water is a byproduct. If water is not removed, the reaction hits thermodynamic equilibrium.
- **Aldol Competition:** Under basic conditions, the ketone partner may undergo self-Aldol condensation instead of reacting with the aminobenzophenone.

### Troubleshooting Q&A

Q: I am using traditional reflux in ethanol with KOH, but the yield is poor. Why? A: Ethanol reflux (78°C) is often insufficient to drive the dehydration step for sterically hindered substrates.

Furthermore, base catalysis promotes self-condensation of the ketone.

- **The Fix:** Switch to Acid Catalysis (e.g., catalytic  $\text{H}_2\text{SO}_4$  or  $p\text{-TsOH}$ ) to suppress self-Aldol. Even better, use Neat Acetic Acid.

Q: How do I push the reaction to completion without harsh acids? A: Use Microwave Irradiation.

- **Mechanism:** Microwave heating provides rapid, uniform energy that overcomes the activation barrier for the rate-determining dehydration step much faster than convective heating.
- **Green Alternative:** Use Ionic Liquids (e.g.,  $[\text{bmim}]\text{HSO}_4$ ) or Nafion NR50 (solid acid).<sup>[5]</sup> These act as both solvent and catalyst, often improving yields to >90% by stabilizing the transition state.

## Module 3: Metal-Catalyzed & Green Synthesis

The Symptom: The reaction works on 50mg scale but fails on 5g scale.

### Root Cause Analysis

Modern methods (Iron, Ruthenium, or Copper catalysis) often rely on Acceptorless Dehydrogenative Coupling (ADC).

- **Mass Transfer:** These reactions often require the release of  $\text{H}_2$  gas or the uptake of  $\text{O}_2$  (if aerobic). On a larger scale, gas exchange becomes the limiting factor.
- **Catalyst Deactivation:** In Iron-catalyzed reactions, the active species is often a heterogeneous nanoparticle. If these aggregate or are poisoned by byproducts, the reaction dies.

### Troubleshooting Q&A

Q: My Iron-catalyzed reaction stops after 1 hour. Is the catalyst dead? A: Likely. Iron catalysts are sensitive to aggregation.

- **The Fix:** Ensure vigorous stirring (to keep nanoparticles dispersed). If using an aerobic oxidation step, switch from a balloon to a slow bubbler to ensure constant  $\text{O}_2$  saturation.

Q: Can I avoid toxic oxidants like nitrobenzene? A: Yes. Modern protocols utilize Aerobic Oxidation (O<sub>2</sub>/Air) or Photocatalysis.

- Pro-Tip: For Povarov reactions (forming 2,4-diarylquinolines), FeCl<sub>3</sub> is an excellent, cheap, and environmentally benign catalyst that avoids the need for stoichiometric oxidants.

## Data Summary: Common Failure Modes

Synthesis Method	Primary Failure Mode	Visual Indicator	Optimization Strategy
Skraup	Polymerization of Acrolein	Black Tar / "Goo"	Add FeSO <sub>4</sub> ; Ramp temp slowly (140°C to 160°C).
Friedländer	Equilibrium Stalling	Unreacted Starting Material	Microwave (160°C); Use Ionic Liquids; Remove water.
Combes	Regioselectivity Issues	Mixture of Isomers	Use Enaminone intermediates; Switch acid catalyst (p-TsOH vs HCl).
Metal-Catalyzed	Mass Transfer / Poisoning	Reaction stops at low conv.	Increase stirring; Check O <sub>2</sub> flow; Use Nafion (heterogeneous).

## Featured Protocol: Microwave-Assisted Green Friedländer Synthesis

Rationale: This protocol overcomes the "stalled equilibrium" issue of classical methods and eliminates toxic solvents.

Reagents:

- 2-Aminobenzophenone (1.0 equiv)

- Acetylacetone or Cyclic Ketone (1.2 equiv)
- Solvent/Catalyst: Neat Glacial Acetic Acid (or [bmim]HSO<sub>4</sub> for solvent-free)

#### Workflow:

- Preparation: In a 10 mL microwave vial, combine 2-aminobenzophenone (1 mmol) and the ketone (1.2 mmol).
- Solvent: Add 2 mL of Glacial Acetic Acid. Cap the vial.
- Irradiation: Set Microwave reactor to 160°C (High Absorption).
- Time: Hold for 5–10 minutes. (Compare to 24h reflux).
- Workup: Pour mixture into crushed ice/water. Neutralize with saturated NaHCO<sub>3</sub>. The quinoline usually precipitates as a solid. Filter and wash.<sup>[6]</sup>

## Protocol Visualization

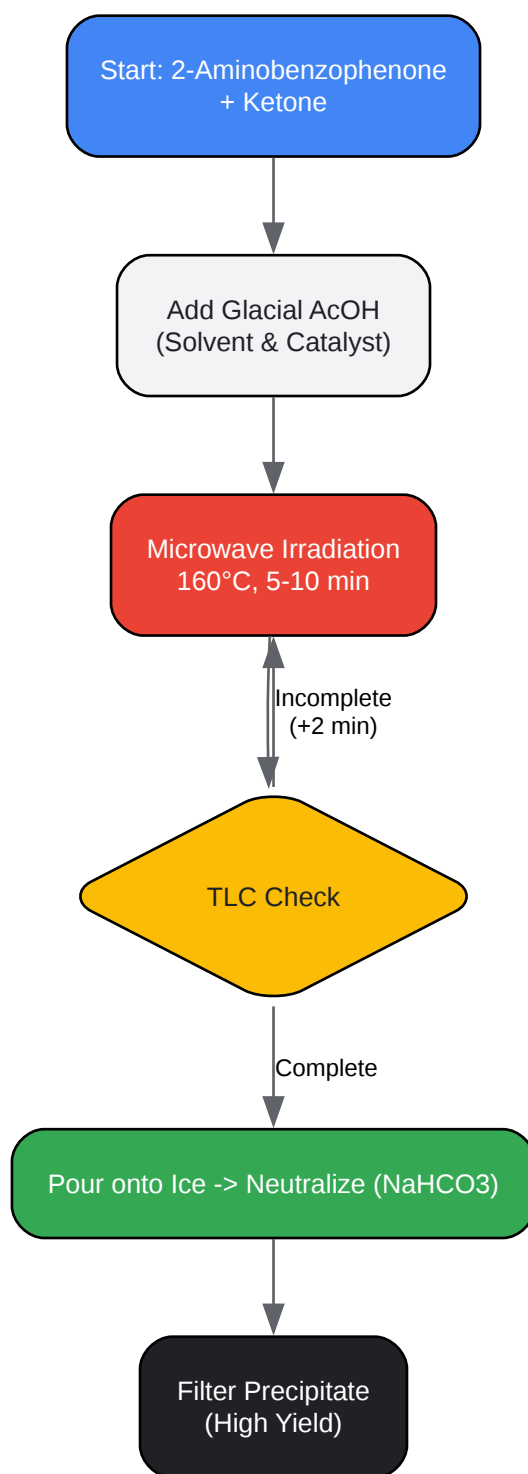

[Click to download full resolution via product page](#)

Figure 2: Optimized Workflow for Microwave-Assisted Friedländer Synthesis.

## References

- Organic Syntheses. Quinoline Synthesis via Skraup Reaction.[1][2][3][7][8] Coll. Vol. 1, p.478 (1941). Available at: [\[Link\]](#)
- Gould, E. et al. Rapid and Efficient Microwave-Assisted Friedländer Quinoline Synthesis. National Institutes of Health (NIH) / PMC. (2020). Available at: [\[Link\]](#)
- Chan, C.-K. et al. Environmentally Friendly Nafion-Mediated Friedländer Quinoline Synthesis under Microwave Irradiation.[9] Organic Chemistry Portal / Synthesis. (2020). Available at: [\[Link\]](#)
- Wang, S. et al. Recent Advances in the Synthesis of Quinolines: A Focus on Oxidative Annulation Strategies. MDPI. (2022). Available at: [\[Link\]](#)

### Need Custom Synthesis?

BenchChem offers custom synthesis for rare earth carbides and specific isotopic labeling.

Email: [info@benchchem.com](mailto:info@benchchem.com) or [Request Quote Online](#).

## Sources

- [1. pdf.benchchem.com \[pdf.benchchem.com\]](#)
- [2. pdf.benchchem.com \[pdf.benchchem.com\]](#)
- [3. Organic Syntheses Procedure \[orgsyn.org\]](#)
- [4. pdf.benchchem.com \[pdf.benchchem.com\]](#)
- [5. mdpi.com \[mdpi.com\]](#)
- [6. Rapid and Efficient Microwave-Assisted Friedländer Quinoline Synthesis - PMC \[pmc.ncbi.nlm.nih.gov\]](#)
- [7. iipseries.org \[iipseries.org\]](#)
- [8. Recent Advances in Metal-Free Quinoline Synthesis - PMC \[pmc.ncbi.nlm.nih.gov\]](#)
- [9. Environmentally Friendly Nafion-Mediated Friedländer Quinoline Synthesis under Microwave Irradiation: Application to One-Pot Synthesis of Substituted Quinolinylnyl Chalcones \[organic-chemistry.org\]](#)
- To cite this document: BenchChem. [Technical Support Center: Optimization of Quinoline Synthesis]. BenchChem, [2026]. [Online PDF]. Available at:

[<https://www.benchchem.com/product/b1454296/docs#technical-support-center-optimization-of-quinoline-synthesis>]

### Disclaimer & Data Validity:

The information provided in this document is for Research Use Only (RUO) and is strictly not intended for diagnostic or therapeutic procedures. While BenchChem strives to provide accurate protocols, we make no warranties, express or implied, regarding the fitness of this product for every specific experimental setup.

**Technical Support:** The protocols provided are for reference purposes. Unsure if this reagent suits your experiment?

**Need Industrial/Bulk Grade?** [Request Custom Synthesis Quote](#)

## BenchChem

Our mission is to be the trusted global source of essential and advanced chemicals, empowering scientists and researchers to drive progress in science and industry.

### Contact

Address: 3281 E Guasti Rd  
Ontario, CA 91761, United States  
Phone: (601) 213-4426  
Email: [info@benchchem.com](mailto:info@benchchem.com)

[Contact our Ph.D. Support Team for a compatibility check](#)