

Technical Monograph: 2-Chloro-4-cyclopropylphenol

Author: BenchChem Technical Support Team. **Date:** May 2026

Compound of Interest

Compound Name: 2-Chloro-4-cyclopropylphenol

CAS No.: 1553103-02-8

Cat. No.: B1454951

[Get Quote](#)

Executive Summary

2-Chloro-4-cyclopropylphenol (CAS: 1553103-02-8) represents a high-value pharmacophore building block, integrating the lipophilic modulation of a cyclopropyl group with the electronic tuning of an ortho-chlorine substituent.^{[1][2]} In medicinal chemistry, this scaffold serves as a critical bioisostere, offering improved metabolic stability compared to isopropyl analogues while maintaining steric equivalence.^{[1][2]}

This guide provides a comprehensive technical analysis of the compound, detailing validated synthetic routes, physicochemical profiling, and downstream reactivity patterns essential for lead optimization in kinase inhibitor and G-protein coupled receptor (GPCR) ligand development.^{[1][2]}

Chemical Identity & Physicochemical Profile^{[1][2][3]} ^{[4][5][6][7][8]}

The unique combination of an electron-withdrawing chlorine atom and a weak electron-donating cyclopropyl ring creates a distinct electronic environment around the phenolic

hydroxyl group.[1][2] This modulation affects both the acidity () and the nucleophilicity of the oxygen, influencing subsequent derivatization.[2]

Table 1: Physicochemical Properties

| Property | Value / Description | Source/Estimation Basis |
|-------------------|--|---|
| CAS Number | 1553103-02-8 | Confirmed Registry |
| Molecular Formula | | Stoichiometry |
| Molecular Weight | 168.62 g/mol | Calculated |
| Appearance | White to pale yellow crystalline solid | Analogous phenolic trends |
| Predicted | 9.5 – 9.8 | Acidified vs. phenol (10.[1][2][3][4]0) by o-Cl |
| Predicted LogP | ~3.3 | Lipophilic shift due to cyclopropyl |
| H-Bond Donors | 1 (Phenolic OH) | Structural analysis |
| H-Bond Acceptors | 1 (Phenolic OH) | Structural analysis |

“

Analyst Note: The cyclopropyl group at the para position blocks metabolic hydroxylation often seen with alkyl chains, while the ortho-chlorine sterically protects the phenolic oxygen, potentially reducing Phase II glucuronidation rates.[1]

Synthetic Methodologies

To ensure high purity and regioselectivity, two primary synthetic strategies are recommended depending on the starting material availability and scale requirements.[1][2]

Strategy A: Regioselective Chlorination (Process Scale)

Direct chlorination of 4-cyclopropylphenol is the most atom-economical route.^{[1][2]} However, controlling over-chlorination (dichloro species) is critical.^[2]

- Reagents: N-Chlorosuccinimide (NCS) or Sulfuryl Chloride (SO₂Cl₂).^{[1][2]}
- Solvent: Acetonitrile (MeCN) or DMF.^{[1][2]}
- Mechanism: Electrophilic Aromatic Substitution (EAS).^{[1][2]} The cyclopropyl group activates the ortho position, but the first chlorine deactivates the ring, naturally limiting di-chlorination if stoichiometry is controlled.^[1]

Strategy B: Suzuki-Miyaura Cross-Coupling (Discovery Scale)

Used when 4-cyclopropylphenol is unavailable, this route builds the carbon skeleton from halogenated precursors.^{[1][2]}

- Precursors: 4-Bromo-2-chlorophenol + Cyclopropylboronic acid.^{[1][2]}
- Catalyst:
Pd(PPh₃)₄Cl₂
or
PdCl₂(PPh₃)₂.^[2]
- Base:
K₂CO₃
or
Na₂CO₃.^{[1][2]}

Visualization: Synthetic Pathways

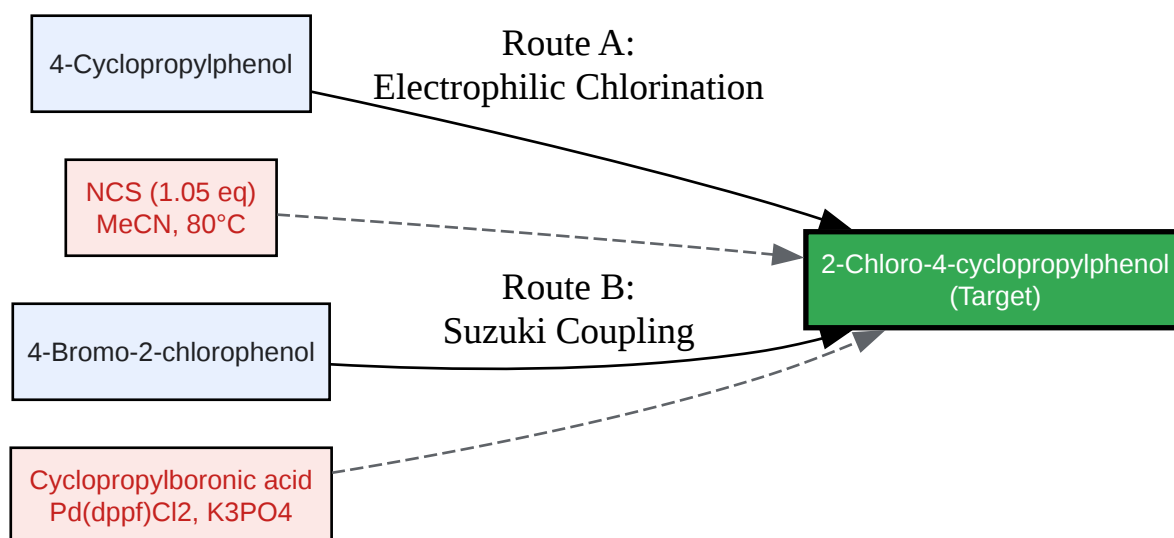

Figure 1: Primary Synthetic Strategies for 2-Chloro-4-cyclopropylphenol

[Click to download full resolution via product page](#)

Detailed Experimental Protocol (Route A)

Objective: Synthesis of **2-Chloro-4-cyclopropylphenol** via NCS Chlorination. Scale: 10 mmol (Laboratory Scale).

Reagents & Equipment[2][9]

- 4-Cyclopropylphenol (1.34 g, 10 mmol)[1][2]
- N-Chlorosuccinimide (NCS) (1.40 g, 10.5 mmol)[1][2]
- Acetonitrile (anhydrous, 20 mL)
- p-Toluenesulfonic acid (pTsoH) (catalytic, 10 mol%) - Optional, accelerates reaction.[1][2]

Step-by-Step Methodology

- Dissolution: In a 50 mL round-bottom flask equipped with a magnetic stir bar, dissolve 4-cyclopropylphenol in 20 mL of acetonitrile.
- Activation: Add pTsoH (170 mg) if faster kinetics are required. (Acid catalysis protonates NCS, increasing electrophilicity).[2]

- Addition: Add NCS portion-wise over 15 minutes at room temperature ().
 - Why: Exothermic control and prevention of localized high concentrations that favor dichlorination.[\[1\]](#)[\[2\]](#)
- Reaction: Heat the mixture to and stir for 4–6 hours. Monitor via TLC (Hexane/EtOAc 8:2) or LC-MS.[\[1\]](#)[\[2\]](#)
- Quench: Cool to room temperature. Pour the mixture into 50 mL of saturated sodium thiosulfate solution () to neutralize unreacted active chlorine.[\[1\]](#)[\[2\]](#)
- Extraction: Extract with Ethyl Acetate (mL). Wash combined organics with brine, dry over , and concentrate in vacuo.
- Purification: Purify via silica gel flash chromatography (Gradient: 0-10% EtOAc in Hexanes).

Validation Criteria:

- ¹H NMR (): Look for the disappearance of the symmetric para-phenol pattern and appearance of an ABC aromatic system. The cyclopropyl protons (0.6–1.0 ppm) should remain intact.[\[1\]](#)[\[2\]](#)
- MS (ESI-): Expected [M-H]⁻ = 167.0.[\[1\]](#)[\[2\]](#)

Reactivity & Applications in Drug Design[\[1\]](#)

The **2-chloro-4-cyclopropylphenol** scaffold is versatile.[\[1\]](#)[\[2\]](#) The phenolic oxygen is the primary nucleophile, while the aryl chloride offers a handle for late-stage diversification, albeit requiring specialized ligands due to the lower reactivity of aryl chlorides compared to bromides.
[\[1\]](#)

Key Reaction Pathways[2]

- O-Alkylation/Acylation: Standard Williamson ether synthesis or esterification to attach the phenol to a larger pharmacophore core.[1][2]
- Buchwald-Hartwig Amination: Displacement of the ortho-chlorine (challenging but feasible with bulky phosphine ligands like BrettPhos) to create N-aryl bonds.[1][2]
- Cyclopropyl Ring Opening: Under strongly acidic conditions (e.g., concentrated H_2SO_4), the cyclopropyl ring can open to form a propyl chain, often an unwanted side reaction to be avoided.[1][2]

Visualization: Reactivity Logic

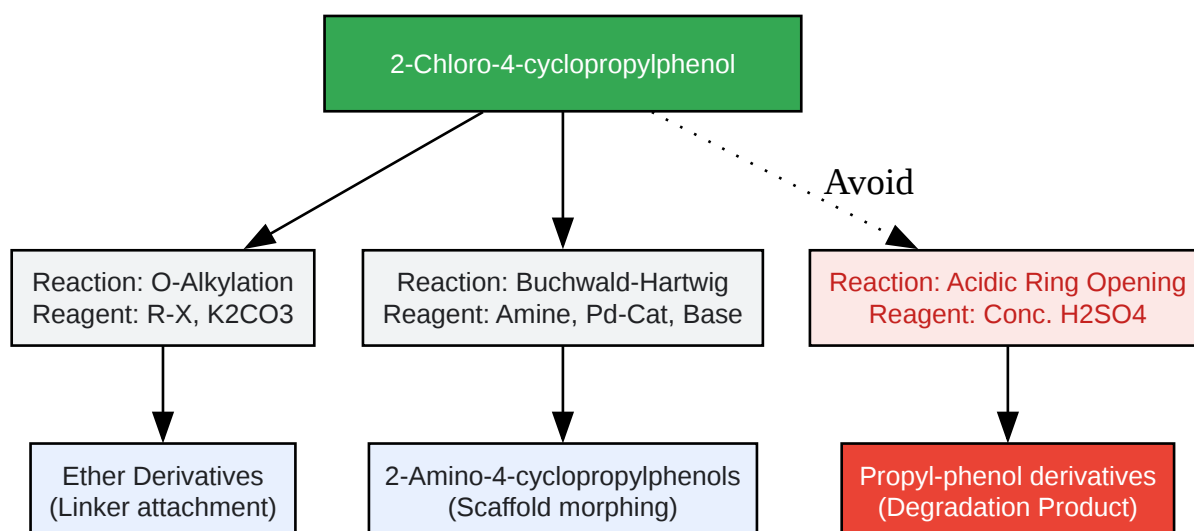

Figure 2: Reactivity Profile and Derivatization Potential

[Click to download full resolution via product page](#)

[1][2][5][10][11][12]

Safety & Handling (SDS Summary)

While specific toxicological data for this exact isomer is limited, protocols should follow the "Read-Across" method from 2-chlorophenol and 4-cyclopropylphenol.[1][2]

- Hazards:

- Skin/Eye Irritant: Phenolic compounds are corrosive/irritating.[1][2][5] Wear nitrile gloves and safety goggles.[1][2]
- Acute Toxicity: Harmful if swallowed (Category 4).[1][2][5]
- Storage: Store in a cool, dry place under inert atmosphere (Nitrogen/Argon). Phenols can oxidize (darken) over time upon air exposure.[1][2]
- Disposal: Halogenated organic waste streams. Do not mix with acid waste streams to prevent potential gas evolution.[1][2]

References

- National Institutes of Health (NIH) - PubChem. (2025).[1][2] Compound Summary: 4-Chloro-2-cyclopropylphenol (Isomer Analog Data).[1][2] Retrieved from [\[Link\]](#)
- ChemicalRegister. (2025).[1][2][3][6] Supplier and CAS Verification for 1553103-02-8. Retrieved from [\[Link\]](#)
- Accela ChemBio. (2023).[1][2][3] Certificate of Analysis and SDS Data for Catalog SY204032. Retrieved from [\[Link\]](#)
- Smith, M. B. (2020).[1][2] March's Advanced Organic Chemistry: Reactions, Mechanisms, and Structure. 8th Edition.[1][2] Wiley-Interscience.[1][2] (General reference for NCS chlorination mechanisms).

Need Custom Synthesis?

BenchChem offers custom synthesis for rare earth carbides and specific isotopic labeling.

Email: info@benchchem.com or [Request Quote Online](#).

Sources

- 1. [guidechem.com](https://www.guidechem.com) [[guidechem.com](https://www.guidechem.com)]
- 2. [2-Chloro-4-Phenylphenol | C12H9ClO | CID 7074 - PubChem](https://pubchem.ncbi.nlm.nih.gov/compound/2-Chloro-4-Phenylphenol) [pubchem.ncbi.nlm.nih.gov]

- [3. 1820687-31-7,3-cyclopropyl-5-oxa-2-azaspiro\[3.4\]octan-1-one-AccelaChem|AccelaChemBio|Accela design, synthesis, manufacture and market advanced R&D chemicals;韶远科技（上海）有限公司 \[accelachem.com\]](#)
- [4. 2-Chloro-4-cyclopropylphenol \(1553103-02-8\) for sale \[vulcanchem.com\]](#)
- [5. 4-Chloro-2-cyclopropylphenol | C9H9ClO | CID 68326221 - PubChem \[pubchem.ncbi.nlm.nih.gov\]](#)
- [6. 2-Chloro-4-cyclopropylphenol \(CAS No. 1553103-02-8\) Suppliers @ ChemicalRegister.com \[chemicalregister.com\]](#)
- [To cite this document: BenchChem. \[Technical Monograph: 2-Chloro-4-cyclopropylphenol\]. BenchChem, \[2026\]. \[Online PDF\]. Available at: \[https://www.benchchem.com/product/b1454951/docs#technical-monograph-2-chloro-4-cyclopropylphenol\]](#)

Disclaimer & Data Validity:

The information provided in this document is for Research Use Only (RUO) and is strictly not intended for diagnostic or therapeutic procedures. While BenchChem strives to provide accurate protocols, we make no warranties, express or implied, regarding the fitness of this product for every specific experimental setup.

Technical Support: The protocols provided are for reference purposes. Unsure if this reagent suits your experiment?

Need Industrial/Bulk Grade? [Request Custom Synthesis Quote](#)

BenchChem

Our mission is to be the trusted global source of essential and advanced chemicals, empowering scientists and researchers to drive progress in science and industry.

Contact

Address: 3281 E Guasti Rd
Ontario, CA 91761, United States
Phone: (601) 213-4426
Email: info@benchchem.com

Contact our Ph.D. Support Team for a compatibility check