

Application Notes and Protocols for the Synthesis of Functionalized Pyrazole Derivatives

Author: BenchChem Technical Support Team. **Date:** May 2026

Compound of Interest

Compound Name: 2-(4-chloro-3,5-dimethyl-1H-pyrazol-1-yl)ethanamine

CAS No.: 925634-46-4

Cat. No.: B1309019

[Get Quote](#)

Introduction: The Privileged Role of Pyrazoles in Modern Chemistry

The pyrazole nucleus, a five-membered aromatic heterocycle containing two adjacent nitrogen atoms, stands as a cornerstone in medicinal chemistry and drug discovery.^{[1][2]} Its remarkable versatility and ability to engage in various biological interactions have cemented its status as a "privileged scaffold."^{[3][4]} Pyrazole derivatives exhibit a broad spectrum of pharmacological activities, including anti-inflammatory, antimicrobial, anticancer, and antiviral properties.^{[5][6]} This has led to their incorporation into numerous FDA-approved drugs, such as the COX-2 inhibitor Celecoxib and the anti-obesity agent Rimonabant.^{[2][7]}

The efficacy of pyrazole-based compounds is intrinsically linked to the nature and positioning of their substituents. Consequently, the development of efficient and regioselective synthetic routes to access a diverse array of functionalized pyrazoles is of paramount importance for researchers, scientists, and drug development professionals.^{[8][9]} This guide provides an in-depth exploration of key synthetic methodologies, offering both mechanistic insights and detailed, field-proven protocols.

I. The Knorr Pyrazole Synthesis: A Classic and Enduring Strategy

First reported by Ludwig Knorr in 1883, the Knorr pyrazole synthesis remains one of the most fundamental and widely employed methods for constructing the pyrazole ring.[2][10] The reaction involves the condensation of a hydrazine or its derivative with a 1,3-dicarbonyl compound, typically under acidic conditions.[11][12]

Mechanistic Insights

The reaction proceeds through an initial acid-catalyzed formation of an imine between the hydrazine and one of the carbonyl groups of the 1,3-dicarbonyl compound.[10][13] The second nitrogen atom of the hydrazine then acts as a nucleophile, attacking the remaining carbonyl group to form a second imine, leading to a cyclized intermediate.[11][14] Subsequent dehydration of this intermediate yields the aromatic pyrazole ring.[15] A critical consideration in the Knorr synthesis, particularly with unsymmetrical 1,3-dicarbonyls and substituted hydrazines, is the potential for the formation of regioisomers.[8][16]

Visualizing the Knorr Pyrazole Synthesis

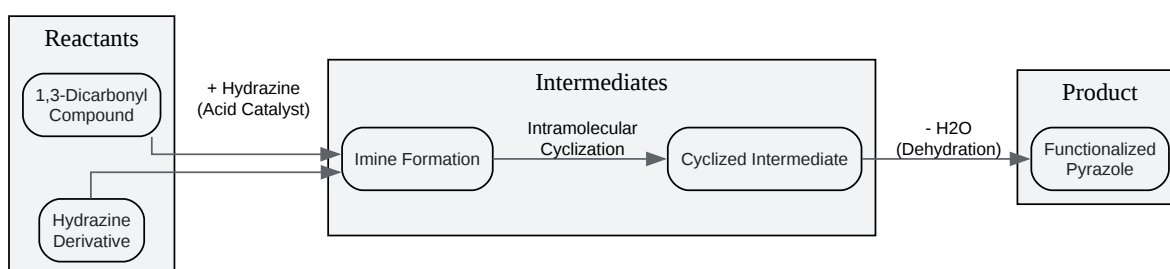

[Click to download full resolution via product page](#)

Caption: Generalized workflow of the Knorr Pyrazole Synthesis.

Protocol: Synthesis of 3,5-Dimethylpyrazole

This protocol details the synthesis of 3,5-dimethylpyrazole from acetylacetone and hydrazine hydrate, a classic example of the Knorr synthesis.

Materials:

- Acetylacetone (1,3-pentanedione)
- Hydrazine hydrate
- Ethanol
- Ammonium chloride (as a green catalyst)[17]
- Distilled water
- Standard laboratory glassware (round-bottom flask, condenser, etc.)
- Magnetic stirrer and hotplate

Procedure:

- In a 100 mL round-bottom flask equipped with a magnetic stir bar, dissolve acetylacetone (0.1 mol) in 30 mL of ethanol.
- Add a catalytic amount of ammonium chloride (0.01 mol).[17]
- Slowly add hydrazine hydrate (0.1 mol) dropwise to the stirred solution at room temperature. An exothermic reaction may be observed.
- After the addition is complete, fit the flask with a reflux condenser and heat the mixture to reflux for 1-2 hours.
- Monitor the reaction progress by Thin Layer Chromatography (TLC).
- Once the reaction is complete, cool the mixture to room temperature.
- Pour the reaction mixture into 100 mL of cold distilled water with stirring.
- The product, 3,5-dimethylpyrazole, will precipitate as a white solid.

- Collect the solid by vacuum filtration and wash with cold water.
- Recrystallize the crude product from a suitable solvent (e.g., ethanol/water mixture) to obtain pure 3,5-dimethylpyrazole.

Expected Yield: 80-90%

II. Multicomponent Reactions (MCRs): A Paradigm of Efficiency

Multicomponent reactions (MCRs) have emerged as a powerful and sustainable strategy for the synthesis of complex molecules, including functionalized pyrazoles.^{[3][18]} These one-pot reactions involve the combination of three or more starting materials to form a product that incorporates most of the atoms of the reactants.^[19] MCRs offer significant advantages over traditional multi-step syntheses, including operational simplicity, time and energy savings, and high atom economy.^{[4][20]}

Mechanistic Considerations in Pyrazole-forming MCRs

A common MCR approach to pyrazoles involves the reaction of an aldehyde, an active methylene compound (like malononitrile), a hydrazine, and a β -ketoester.^[21] The reaction cascade often begins with a Knoevenagel condensation between the aldehyde and the active methylene compound, followed by a Michael addition of the pyrazolone (formed in situ from the hydrazine and β -ketoester).^{[16][18]} Subsequent intramolecular cyclization and dehydration lead to the final, highly substituted pyrazole derivative.^[21]

Visualizing a Four-Component Pyrano[2,3-c]pyrazole Synthesis

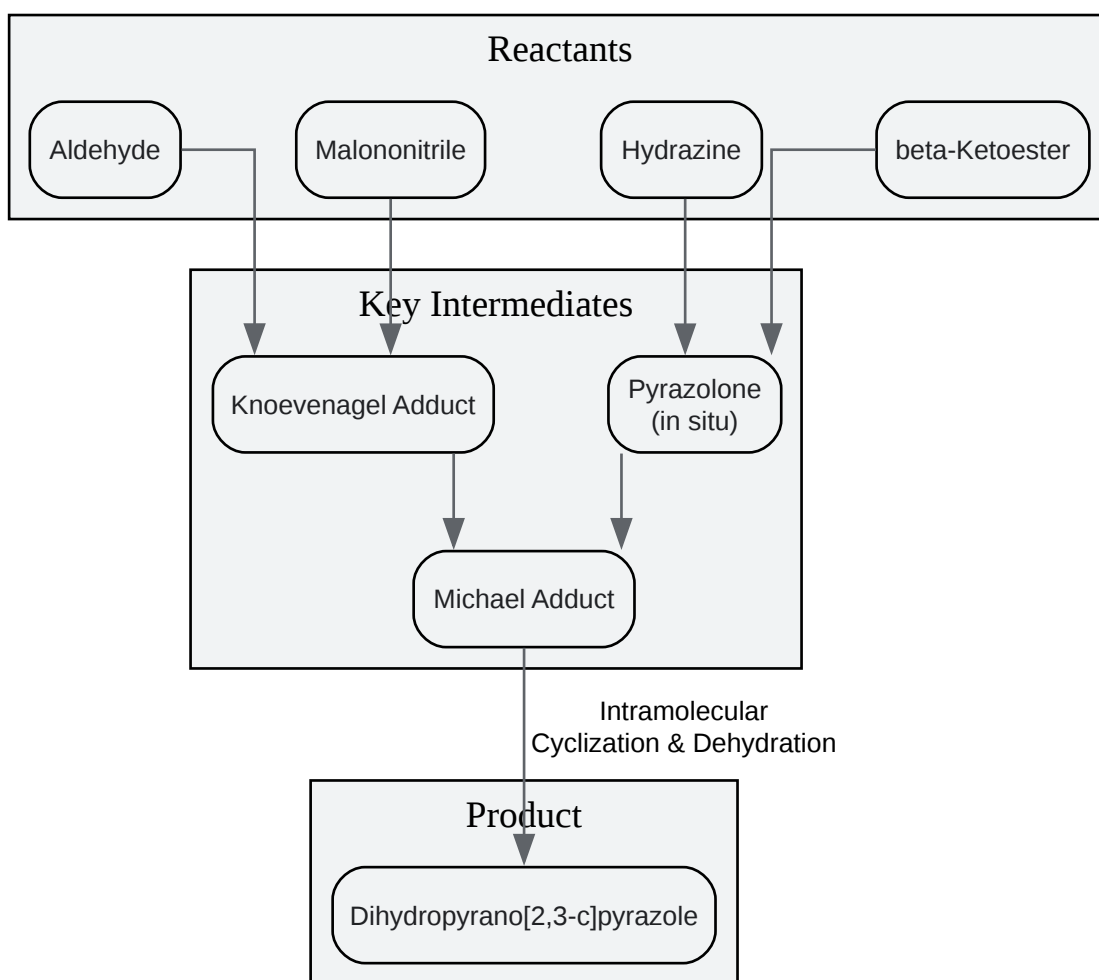

[Click to download full resolution via product page](#)

Caption: A representative four-component reaction for pyranopyrazole synthesis.

Protocol: One-Pot Synthesis of Dihydropyrano[2,3-c]pyrazole Derivatives

This protocol describes a green, efficient, one-pot, four-component synthesis of dihydropyrano[2,3-c]pyrazoles in an aqueous medium.[18]

Materials:

- Aromatic aldehyde
- Malononitrile

- Ethyl acetoacetate
- Hydrazine hydrate
- Piperidine (catalyst)
- Water

Procedure:

- In a 50 mL round-bottom flask, combine the aromatic aldehyde (1 mmol), malononitrile (1 mmol), ethyl acetoacetate (1 mmol), and hydrazine hydrate (1 mmol) in 10 mL of water.
- Add a catalytic amount of piperidine (5 mol%).
- Stir the reaction mixture vigorously at room temperature for 20-30 minutes.
- Monitor the reaction by TLC. A solid product will typically precipitate out of the solution.
- Collect the solid product by vacuum filtration.
- Wash the solid with cold water and then a small amount of cold ethanol to remove any unreacted starting materials.
- The product is often pure enough for characterization, but can be further purified by recrystallization if necessary.

Expected Yield: 85-95%

III. (3+2) Cycloaddition Reactions: A Powerful Ring-Forming Tool

1,3-Dipolar cycloaddition reactions represent a highly efficient and regioselective method for the synthesis of five-membered heterocycles, including pyrazoles.^{[22][23]} This approach involves the reaction of a 1,3-dipole with a dipolarophile. For pyrazole synthesis, common 1,3-dipoles include diazo compounds and nitrilimines, which react with alkynes or alkenes as dipolarophiles.^{[22][24]}

Mechanistic Principles

The reaction of a diazo compound with an alkyne is a classic example of a Huisgen 1,3-dipolar cycloaddition.[23] The concerted [3+2] cycloaddition leads directly to the pyrazole ring.[22] The regioselectivity of the addition is governed by the electronic and steric properties of the substituents on both the diazo compound and the alkyne. In some cases, alkyne surrogates, such as α -bromocinnamaldehyde, can be used to achieve high regioselectivity.[23]

Visualizing the [3+2] Cycloaddition for Pyrazole Synthesis

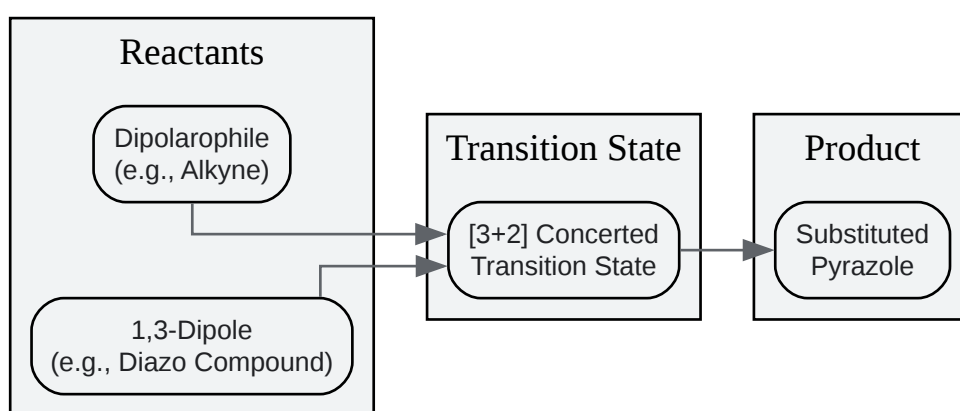

[Click to download full resolution via product page](#)

Caption: The concerted [3+2] cycloaddition pathway for pyrazole synthesis.

Protocol: Catalyst-Free Synthesis of Pyrazoles from Diazo Compounds and Alkynes

This protocol outlines a green, solvent-free approach to pyrazole synthesis via the thermal [3+2] cycloaddition of α -diazocarbonyl compounds with alkynes.[22]

Materials:

- α -Diazocarbonyl compound (e.g., ethyl diazoacetate)
- Alkyne (e.g., dimethyl acetylenedicarboxylate)

- Reaction vial with a screw cap

Procedure:

- In a small reaction vial, carefully mix the α -diazocarbonyl compound (1 mmol) and the alkyne (1.1 mmol). Caution: Diazo compounds can be explosive and should be handled with care in a well-ventilated fume hood.
- Seal the vial and heat the mixture in an oil bath at a predetermined temperature (typically 80-120 °C).
- Monitor the reaction by TLC until the diazo compound is consumed.
- Cool the reaction mixture to room temperature.
- The resulting product is often obtained in high purity and may not require further purification. If necessary, purification can be achieved by column chromatography on silica gel.

Expected Yield: High to quantitative.

IV. Modern Approaches: Metal-Catalyzed and C-H Functionalization Strategies

While classical methods for pyrazole synthesis are robust, modern organic chemistry has introduced more sophisticated strategies, including transition-metal-catalyzed reactions and direct C-H functionalization.^{[9][25]} These methods offer novel pathways to previously inaccessible pyrazole derivatives and often proceed with high regioselectivity and efficiency.^{[25][26]}

- **Metal-Catalyzed Cycloadditions:** Copper and silver catalysts have been shown to promote the [3+2] cycloaddition of hydrazines with alkynes, providing a regioselective route to polysubstituted pyrazoles.^{[27][28]}
- **Direct C-H Functionalization:** The direct functionalization of C-H bonds on a pre-formed pyrazole ring is a powerful strategy for late-stage modification.^{[9][25]} This approach avoids the need for pre-functionalized starting materials and allows for the direct introduction of various substituents.

Conclusion and Future Outlook

The synthesis of functionalized pyrazole derivatives is a dynamic and evolving field. While traditional methods like the Knorr synthesis remain indispensable, modern approaches such as multicomponent reactions and metal-catalyzed C-H functionalization are expanding the horizons of what is achievable. The continued development of novel, efficient, and sustainable synthetic methodologies will undoubtedly fuel the discovery of new pyrazole-based therapeutics and advanced materials.

References

- Ebenezer, O., Shapi, M., & Tuszynski, J.A. (2022).
- Recent Applications of the Multicomponent Synthesis for Bioactive Pyrazole Derivatives. (2022). *Molecules*. [\[Link\]](#)
- Recent advances in the multicomponent synthesis of pyrazoles. (2024). *Organic & Biomolecular Chemistry*. [\[Link\]](#)
- Karrouchi, K., Radi, S., Ramli, Y., Taoufik, J., Mabkhot, Y.N., Al-aizari, F.A., & Ansar, M. (2018). Synthesis and pharmacological activities of pyrazole derivatives: A review. *Molecules*, 23. [\[Link\]](#)
- Recent Advances in the Synthesis of Pyrazole Derivatives: A Review. (2023). *Reactions*. [\[Link\]](#)
- Recent Applications of the Multicomponent Synthesis for Bioactive Pyrazole Deriv
- Multicomponent syntheses of pyrazoles via (3 + 2)-cyclocondensation and (3 + 2)-cycloaddition key steps. (2024). *Beilstein Journal of Organic Chemistry*. [\[Link\]](#)
- Recent Synthetic Advances in C–H/N–H Functionalization of 1H-Pyrazoles: Diverse Strategies Across Various Substituted Scaffolds. (2025). *Chemistry – A European Journal*. [\[Link\]](#)
- HFIP-Mediated Multicomponent Reactions: Synthesis of Pyrazole-Linked Thiazole Derivatives. (n.d.). *The Journal of Organic Chemistry*. [\[Link\]](#)

- Multicomponent syntheses of pyrazoles via (3 + 2)-cyclocondensation and (3 + 2)-cycloaddition key steps. (2024). National Institutes of Health. [\[Link\]](#)
- Recent Advances in the Synthesis of Pyrazoles. A Review. (n.d.). Taylor & Francis Online. [\[Link\]](#)
- Review: biologically active pyrazole derivatives. (n.d.). RSC Publishing. [\[Link\]](#)
- Synthesis of pyrazoles through catalyst-free cycloaddition of diazo compounds to alkynes. (n.d.). RSC Publishing. [\[Link\]](#)
- Recent Applications of the Multicomponent Synthesis for Bioactive Pyrazole Derivatives. (2022). MDPI. [\[Link\]](#)
- Synthesis of Novel Pyrazoles via [2+3]-Dipolar Cycloaddition Using Alkyne Surrogates. (n.d.). National Institutes of Health. [\[Link\]](#)
- Recent Advances in the Synthesis of Pyrazole Derivatives. (2021). PubMed. [\[Link\]](#)
- Aerobic Oxidative Cycloaddition Reactions for Pyrazole Synthesis. (2023). Synfacts. [\[Link\]](#)
- Recent Advances in Synthesis and Properties of Pyrazoles. (n.d.). Semantic Scholar. [\[Link\]](#)
- Pyrazole synthesis. (n.d.). Organic Chemistry Portal. [\[Link\]](#)
- Recent advances in the multicomponent synthesis of pyrazoles. (2024). RSC Publishing. [\[Link\]](#)
- Multicomponent syntheses of pyrazoles via (3 + 2)-cyclocondensation and (3 + 2)-cycloaddition key steps. (2024). Beilstein Journals. [\[Link\]](#)
- synthesis of pyrazoles. (2019). YouTube. [\[Link\]](#)
- Knorr Pyrazole Synthesis (M. Pharm). (n.d.). Slideshare. [\[Link\]](#)
- A Review of the Recent Development in the Synthesis and Biological Evaluations of Pyrazole Derivatives. (n.d.). National Institutes of Health. [\[Link\]](#)

- knorr pyrazole synthesis. (n.d.). Slideshare. [\[Link\]](#)
- Knorr pyrazole synthesis. (n.d.). Name-Reaction.com. [\[Link\]](#)
- Synthesis of Fully Substituted Pyrazoles via Regio- and Chemoselective Metalations. (n.d.). ACS Publications. [\[Link\]](#)
- Transition-metal-catalyzed C–H functionalization of pyrazoles. (n.d.). ResearchGate. [\[Link\]](#)
- Temperature-Controlled Divergent Synthesis of Pyrazoles and 1-Tosyl-1H-pyrazoles under Transition-Metal-Catalyst- and Oxidant-Free Conditions. (n.d.). National Institutes of Health. [\[Link\]](#)
- Knorr Pyrazole Synthesis. (n.d.). [\[PDF\]](#).
- Synthesis of Pyrazoles from 1,3-Diols via Hydrogen Transfer Catalysis. (n.d.). ACS Publications. [\[Link\]](#)
- Pyrazole Derivatives: A New Synthesis, Biological Importance, and Recent Practical Applications. (2025). ResearchGate. [\[Link\]](#)
- Knorr Pyrazole Synthesis. (n.d.). Chem Help Asap. [\[Link\]](#)
- Paal-Knorr Pyrrole Synthesis. (n.d.). Organic Chemistry Portal. [\[Link\]](#)
- Synthesis and Pharmacological Activities of Pyrazole Derivatives: A Review. (n.d.). National Institutes of Health. [\[Link\]](#)
- Pyrazole and its Derivatives: An Excellent N-Hetrocycle with Wide Range of Biological Applic
- Paal–Knorr synthesis. (n.d.). Wikipedia. [\[Link\]](#)
- Design, synthesis of novel pyrazole derivatives and demonstrate their biological activity as drug candid
- SYNTHESIS AND EVALUATION OF PYRAZOLE DERIVATIVES BY USING GREEN CATALYST. (n.d.). Jetir.org. [\[Link\]](#)

- Pyrazole and Its Derivatives: An Excellent N-Hetrocycle with Wide Range of Biological Applications (A Review). (n.d.). Oriental Journal of Chemistry. [[Link](#)]
- Paal–Knorr pyrrole synthesis. (n.d.). ResearchGate. [[Link](#)]
- Paal–Knorr synthesis of pyrroles. (2018). [[PDF](#)].

Need Custom Synthesis?

BenchChem offers custom synthesis for rare earth carbides and specific isotopic labeling.

Email: info@benchchem.com or [Request Quote Online](#).

Sources

1. Review: biologically active pyrazole derivatives - New Journal of Chemistry (RSC Publishing) [pubs.rsc.org]
2. chemrevlett.com [chemrevlett.com]
3. Recent Applications of the Multicomponent Synthesis for Bioactive Pyrazole Derivatives [ouci.dntb.gov.ua]
4. Recent Applications of the Multicomponent Synthesis for Bioactive Pyrazole Derivatives - PubMed [pubmed.ncbi.nlm.nih.gov]
5. Recent Advances in the Synthesis of Pyrazole Derivatives - PubMed [pubmed.ncbi.nlm.nih.gov]
6. A Review of the Recent Development in the Synthesis and Biological Evaluations of Pyrazole Derivatives - PMC [pmc.ncbi.nlm.nih.gov]
7. Multicomponent syntheses of pyrazoles via (3 + 2)-cyclocondensation and (3 + 2)-cycloaddition key steps - PMC [pmc.ncbi.nlm.nih.gov]
8. mdpi.com [mdpi.com]
9. Recent Synthetic Advances in C–H/N–H Functionalization of 1H-Pyrazoles: Diverse Strategies Across Various Substituted Scaffolds - PMC [pmc.ncbi.nlm.nih.gov]
10. jk-sci.com [jk-sci.com]
11. name-reaction.com [name-reaction.com]
12. Knorr Pyrazole Synthesis (Chapter 32) - Name Reactions in Organic Synthesis [resolve.cambridge.org]

- [13. Knorr Pyrazole Synthesis \(M. Pharm\) | PPTX \[slideshare.net\]](#)
- [14. m.youtube.com \[m.youtube.com\]](#)
- [15. chemhelpasap.com \[chemhelpasap.com\]](#)
- [16. BJOC - Multicomponent syntheses of pyrazoles via \(3 + 2\)-cyclocondensation and \(3 + 2\)-cycloaddition key steps \[beilstein-journals.org\]](#)
- [17. jetir.org \[jetir.org\]](#)
- [18. Recent Applications of the Multicomponent Synthesis for Bioactive Pyrazole Derivatives - ProQuest \[proquest.com\]](#)
- [19. mdpi.com \[mdpi.com\]](#)
- [20. Recent advances in the multicomponent synthesis of pyrazoles - Organic & Biomolecular Chemistry \(RSC Publishing\) \[pubs.rsc.org\]](#)
- [21. Recent advances in the multicomponent synthesis of pyrazoles - Organic & Biomolecular Chemistry \(RSC Publishing\) \[pubs.rsc.org\]](#)
- [22. Synthesis of pyrazoles through catalyst-free cycloaddition of diazo compounds to alkynes - Green Chemistry \(RSC Publishing\) \[pubs.rsc.org\]](#)
- [23. Synthesis of Novel Pyrazoles via \[2+3\]-Dipolar Cycloaddition Using Alkyne Surrogates - PMC \[pmc.ncbi.nlm.nih.gov\]](#)
- [24. Synthesis and Pharmacological Activities of Pyrazole Derivatives: A Review - PMC \[pmc.ncbi.nlm.nih.gov\]](#)
- [25. researchgate.net \[researchgate.net\]](#)
- [26. pubs.acs.org \[pubs.acs.org\]](#)
- [27. Thieme E-Journals - Synfacts / Abstract \[thieme-connect.com\]](#)
- [28. Pyrazole synthesis \[organic-chemistry.org\]](#)
- To cite this document: BenchChem. [Application Notes and Protocols for the Synthesis of Functionalized Pyrazole Derivatives]. BenchChem, [2026]. [Online PDF]. Available at: [\[https://www.benchchem.com/product/b1309019/docs#application-notes-and-protocols-for-the-synthesis-of-functionalized-pyrazole-derivatives\]](https://www.benchchem.com/product/b1309019/docs#application-notes-and-protocols-for-the-synthesis-of-functionalized-pyrazole-derivatives)

Disclaimer & Data Validity:

The information provided in this document is for Research Use Only (RUO) and is strictly not intended for diagnostic or therapeutic procedures. While BenchChem strives to provide

accurate protocols, we make no warranties, express or implied, regarding the fitness of this product for every specific experimental setup.

Technical Support: The protocols provided are for reference purposes. Unsure if this reagent suits your experiment?

Need Industrial/Bulk Grade? [Request Custom Synthesis Quote](#)

BenchChem

Our mission is to be the trusted global source of essential and advanced chemicals, empowering scientists and researchers to drive progress in science and industry.

Contact

Address: 3281 E Guasti Rd

Ontario, CA 91761, United States

Phone: (601) 213-4426

Email: info@benchchem.com

[Contact our Ph.D. Support Team for a compatibility check](#)