

A Comparative Guide to Piperidine-Based Inhibitors: From Bench to Clinic

Author: BenchChem Technical Support Team. **Date:** May 2026

Compound of Interest

Compound Name: 2-(3-(Hydroxymethyl)piperidin-1-yl)acetic acid
CAS No.: 1156112-79-6
Cat. No.: B1454251

[Get Quote](#)

For Researchers, Scientists, and Drug Development Professionals

The piperidine scaffold is a cornerstone in modern medicinal chemistry, forming the structural basis of numerous FDA-approved drugs.^[1] Its prevalence is a testament to its favorable physicochemical properties and synthetic tractability, allowing for the fine-tuning of pharmacological activity. This guide provides a comparative analysis of prominent piperidine-based inhibitors, focusing on two key therapeutic areas: inflammatory diseases, through the lens of Janus kinase (JAK) inhibitors, and oncology. We will delve into their mechanisms of action, comparative efficacy, and the experimental methodologies used for their evaluation.

The Piperidine Advantage in Drug Design

The six-membered heterocyclic amine structure of piperidine offers a unique combination of features that make it a "privileged scaffold" in drug discovery.^[1] Its conformational flexibility allows it to adapt to the steric requirements of various biological targets. The nitrogen atom can act as a hydrogen bond acceptor or, when protonated, a hydrogen bond donor, facilitating crucial interactions within enzyme active sites or receptor binding pockets. Furthermore, the

piperidine ring is metabolically stable and can improve a drug's pharmacokinetic properties, such as absorption, distribution, metabolism, and excretion (ADME).[2]

Comparative Analysis of Piperidine-Based JAK Inhibitors

The Janus kinase (JAK) family of enzymes (JAK1, JAK2, JAK3, and TYK2) are critical components of the JAK-STAT signaling pathway, which transduces signals for a wide array of cytokines and growth factors involved in immunity and inflammation.[3][4] Dysregulation of this pathway is implicated in numerous autoimmune and inflammatory diseases. Piperidine-containing JAK inhibitors (jakinibs) have emerged as a significant therapeutic class for these conditions.[5]

Mechanism of Action: Quenching the Inflammatory Cascade

The canonical JAK-STAT signaling pathway is initiated when a cytokine binds to its receptor, leading to the activation of receptor-associated JAKs.[6] These activated JAKs then phosphorylate the receptor, creating docking sites for Signal Transducer and Activator of Transcription (STAT) proteins. The STATs are subsequently phosphorylated by the JAKs, causing them to dimerize and translocate to the nucleus, where they regulate the transcription of target genes involved in the inflammatory response.[4] Piperidine-based JAK inhibitors competitively bind to the ATP-binding site of JAK enzymes, preventing the phosphorylation and activation of STATs, thereby blocking the downstream inflammatory signaling.[7]

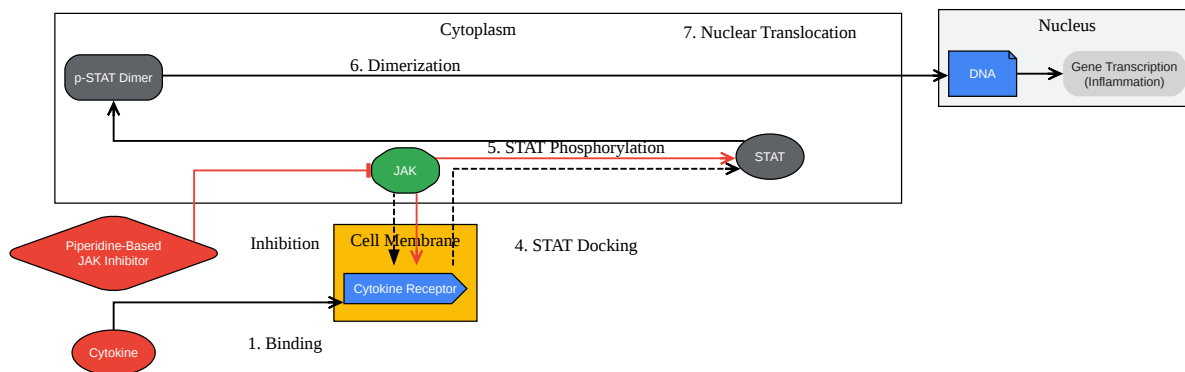

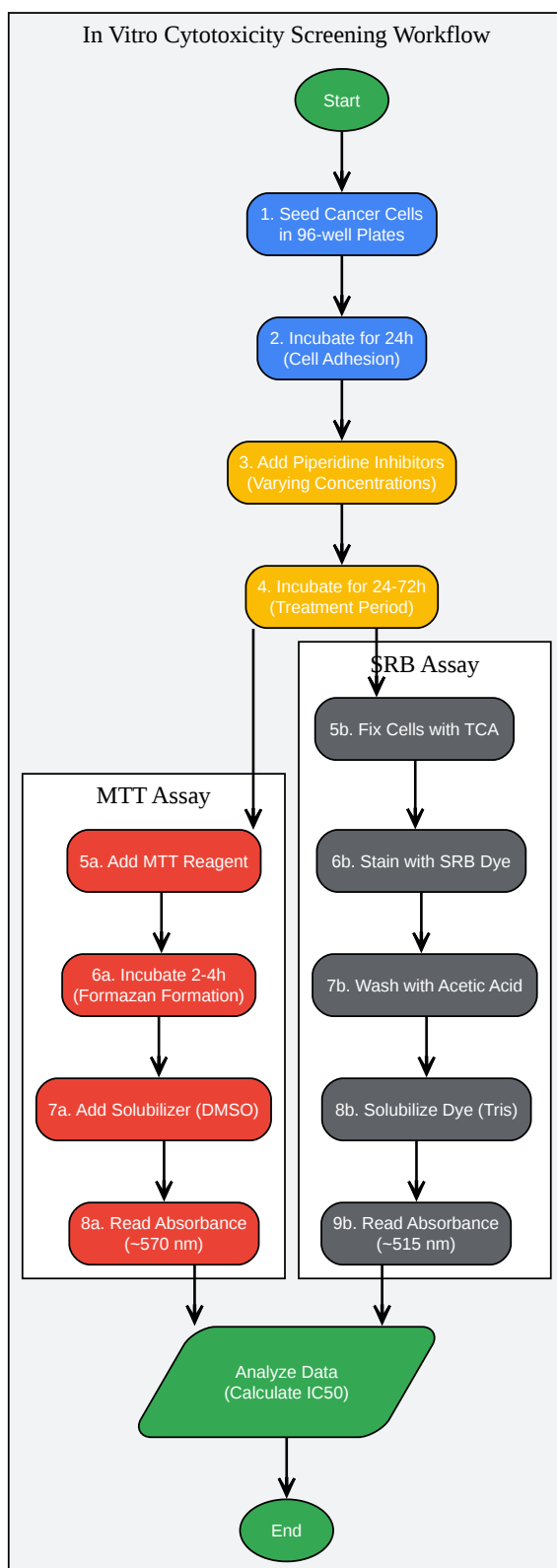

[Click to download full resolution via product page](#)

Caption: A generalized workflow for in vitro anticancer drug screening using MTT and SRB assays.

In Vivo Efficacy Assessment

Promising candidates from in vitro screening are advanced to in vivo studies, often utilizing xenograft models in immunocompromised mice. [8]

- **Cell Preparation and Implantation:** Human cancer cells are cultured and then subcutaneously injected into immunocompromised mice. [9]2. **Tumor Growth Monitoring:** Tumor volume is measured regularly using calipers. [8]3. **Drug Administration:** Once tumors reach a specified size, the piperidine-based inhibitor is administered to the treatment group via an appropriate route (e.g., oral gavage, intraperitoneal injection).
- **Efficacy Evaluation:** Tumor growth in the treated group is compared to a control group receiving a vehicle. Body weight and overall health of the mice are also monitored.
- **Endpoint Analysis:** At the end of the study, tumors can be excised for further analysis, such as histology or biomarker assessment. [9] Many in vitro and in vivo studies have demonstrated the anticancer properties of piperine and piperidine derivatives against various cancer types. [10]

Conclusion

The piperidine scaffold remains a highly valuable framework in the design and development of novel therapeutic inhibitors. This guide has provided a comparative overview of piperidine-based inhibitors in the fields of inflammation and oncology, highlighting their mechanisms of action and the experimental approaches used for their evaluation. The comparative data presented for JAK inhibitors underscores the importance of selectivity in achieving desired therapeutic outcomes while minimizing side effects. The detailed protocols for in vitro cytotoxicity assays offer a practical guide for researchers screening new anticancer compounds. As our understanding of the complex signaling pathways underlying various diseases continues to grow, the versatility of the piperidine scaffold will undoubtedly continue to be exploited in the quest for more effective and safer medicines.

References

► [Click to expand](#)

- McInnes, I. B., et al. (2021). JAK selectivity and the implications for clinical inhibition of pharmacodynamic cytokine signalling by filgotinib, upadacitinib, tofacitinib and baricitinib. *Annals of the Rheumatic Diseases*, 80(5), 623-632. [\[Link\]](#)
- Liao, J., et al. (2024). The efficacy and safety of JAK inhibitors in patients with adult-onset still's disease: A meta-analysis and systematic review. *Clinical Rheumatology*, 43(1), 1-10. [\[Link\]](#)
- Choudhary, R., et al. (2022). Anticancer Applications and Pharmacological Properties of Piperidine and Piperine: A Comprehensive Review on Molecular Mechanisms and Therapeutic Perspectives. *Frontiers in Pharmacology*, 12, 772418. [\[Link\]](#)
- Zhang, Y., et al. (2024). Comparative efficacy and safety of JAK inhibitors in the treatment of moderate-to-severe alopecia areata: a systematic review and network meta-analysis. *Frontiers in Pharmacology*, 15, 1372810. [\[Link\]](#)
- Wei, Y., et al. (2024). Comparative efficacy and safety of Janus kinase inhibitors used in alopecia areata: A systematic review and meta-analysis. *Journal of the European Academy of Dermatology and Venereology*, 38(2), 266-275. [\[Link\]](#)
- Li, M., et al. (2024). Comparative safety profiles of baricitinib and tofacitinib in the treatment of adult alopecia areata: a pharmacovigilance study based on the FAERS database. *Frontiers in Immunology*, 15, 1368595. [\[Link\]](#)
- Sidis, E., & Lencz, T. (2023). A Review on the Safety of Using JAK Inhibitors in Dermatology: Clinical and Laboratory Monitoring. *Dermatology and Therapy*, 13(3), 619-634. [\[Link\]](#)
- O'Donnell, K., & Finn, D. P. (2025). Piperidine-containing drugs and recently studied analogs - biological activity, mechanism of action and synthetic cascade access to their scaffolds. *European Journal of Medicinal Chemistry*, 286, 116901. [\[Link\]](#)
- O'Donnell, K., & Finn, D. P. (2025). Piperidine-containing drugs and recently studied analogs - biological activity, mechanism of action and synthetic cascade access to their scaffolds. *European Journal of Medicinal Chemistry*, 286, 116901. [\[Link\]](#)
- Zheng, Y., et al. (2024). Comparative efficacy and safety of JAK/TYK2 inhibitors and other oral drugs for moderate-to-severe plaque psoriasis: Systematic review and network meta-

- analysis. *Indian Journal of Dermatology, Venereology and Leprology*, 90(5), 596-606. [[Link](#)]
- Wang, G. X., et al. (2014). Discovery and SAR study of piperidine-based derivatives as novel influenza virus inhibitors. *Organic & Biomolecular Chemistry*, 12(39), 7798-7807. [[Link](#)]
 - Liu, Y., et al. (2025). Advances and Challenges in Drug Screening for Cancer Therapy: A Comprehensive Review. *Cancers*, 17(1), 123. [[Link](#)]
 - Wikipedia. (n.d.). JAK-STAT signaling pathway. In Wikipedia. Retrieved January 29, 2024, from [[Link](#)]
 - Clark, J. D., & Malemud, C. J. (2020). Basic Mechanisms of JAK Inhibition. *Rheumatology and Therapy*, 7(Suppl 1), 1-13. [[Link](#)]
 - Vichai, V., & Kirtikara, K. (2006). Sulforhodamine B colorimetric assay for cytotoxicity screening. *Nature Protocols*, 1(3), 1112-1116. [[Link](#)]
 - CLYTE Technologies. (2025). MTT Assay Protocol: Guide to Measuring Cell Viability & Proliferation. Retrieved January 29, 2024, from [[Link](#)]
 - Traore, M., et al. (2018). Pharmacokinetic Optimization of Small Molecule Janus Kinase 3 Inhibitors to Target Immune Cells. *ACS Pharmacology & Translational Science*, 1(2), 94-105. [[Link](#)]
 - Creative Bioarray. (n.d.). Sulforhodamine B (SRB) Assay Protocol. Retrieved January 29, 2024, from [[Link](#)]
 - National Cancer Institute. (n.d.). Classic NCI-60 Screen (Archived). Retrieved January 29, 2024, from [[Link](#)]
 - Mechanism of Action of JAK Inhibitors. (2017, June 6). [Video]. YouTube. [[Link](#)]
 - Dowty, M. E., et al. (2014). The pharmacokinetics, metabolism, and clearance mechanisms of tofacitinib, a janus kinase inhibitor, in humans. *Drug Metabolism and Disposition*, 42(5), 759-773. [[Link](#)]
 - Santana, L., et al. (2021). Targeting the JAK/STAT Pathway: A Combined Ligand- and Target-Based Approach. *Journal of Chemical Information and Modeling*, 61(6), 2825-2837. [[Link](#)]

- Astuti, I., et al. (2024). Piperine: an emerging biofactor with anticancer efficacy and therapeutic potential. BioFactors. [[Link](#)]
- Rittiner, J. E., & Aranda, R. (2013). Cell Viability Assays. In Assay Guidance Manual. Eli Lilly & Company and the National Center for Advancing Translational Sciences. [[Link](#)]
- Houghton, P. J., et al. (2025). Standardized sulforhodamine B colorimetric cell proliferation assay for anticancer activity screening in educational and research laboratories. MethodsX, 12, 102213. [[Link](#)]
- Provost, J. J., & Wallert, M. A. (2018). MTT Proliferation Assay Protocol. [[Link](#)]
- Animated biology With arpan. (2023, October 15). JAK-STAT signaling pathway [Video]. YouTube. [[Link](#)]

Need Custom Synthesis?

BenchChem offers custom synthesis for rare earth carbides and specific isotopic labeling.

Email: info@benchchem.com or [Request Quote Online](#).

Sources

1. Piperidine-containing drugs and recently studied analogs - biological activity, mechanism of action and synthetic cascade access to their scaffolds - PubMed [pubmed.ncbi.nlm.nih.gov]
2. JAK inhibitors: an evidence-based choice of the most appropriate molecule - PMC [pmc.ncbi.nlm.nih.gov]
3. JAK-STAT signaling pathway - Wikipedia [en.wikipedia.org]
4. researchgate.net [researchgate.net]
5. Novel Insights into the JAK Inhibitors Market | Key Analysis [delveinsight.com]
6. bocsci.com [bocsci.com]
7. youtube.com [youtube.com]
8. In vivo Efficacy Studies in Cell Line and Patient-derived Xenograft Mouse Models - PMC [pmc.ncbi.nlm.nih.gov]

- [9. ar.iiarjournals.org \[ar.iiarjournals.org\]](https://ar.iiarjournals.org)
- [10. Anticancer Applications and Pharmacological Properties of Piperidine and Piperine: A Comprehensive Review on Molecular Mechanisms and Therapeutic Perspectives - PMC \[pmc.ncbi.nlm.nih.gov\]](https://pubmed.ncbi.nlm.nih.gov/36111111/)
- To cite this document: BenchChem. [A Comparative Guide to Piperidine-Based Inhibitors: From Bench to Clinic]. BenchChem, [2026]. [Online PDF]. Available at: [\[https://www.benchchem.com/product/b1454251/docs#a-comparative-guide-to-piperidine-based-inhibitors-from-bench-to-clinic\]](https://www.benchchem.com/product/b1454251/docs#a-comparative-guide-to-piperidine-based-inhibitors-from-bench-to-clinic)

Disclaimer & Data Validity:

The information provided in this document is for Research Use Only (RUO) and is strictly not intended for diagnostic or therapeutic procedures. While BenchChem strives to provide accurate protocols, we make no warranties, express or implied, regarding the fitness of this product for every specific experimental setup.

Technical Support: The protocols provided are for reference purposes. Unsure if this reagent suits your experiment?

Need Industrial/Bulk Grade? [Request Custom Synthesis Quote](#)

BenchChem

Our mission is to be the trusted global source of essential and advanced chemicals, empowering scientists and researchers to drive progress in science and industry.

Contact

Address: 3281 E Guasti Rd
Ontario, CA 91761, United States
Phone: (601) 213-4426
Email: info@benchchem.com

[Contact our Ph.D. Support Team for a compatibility check](#)

