

# Application Notes & Protocols: Catalytic Isomerization of Linear Dodecane to Branched Isomers

**Author:** BenchChem Technical Support Team. **Date:** December 2025

## Compound of Interest

Compound Name: 3-Ethyl-2,3,5-trimethylheptane

Cat. No.: B14535098

[Get Quote](#)

Audience: Researchers, scientists, and drug development professionals.

Introduction: The catalytic isomerization of linear alkanes, such as n-dodecane, into their branched isomers is a process of significant industrial importance. The resulting product, commonly known as iso-dodecane, is a mixture of multi-branched C12 alkanes.[1][2] While traditionally used to enhance the octane number of gasoline, iso-dodecane's unique physicochemical properties make it a high-value ingredient for specialized applications.[3] For drug development professionals, iso-dodecane is a particularly valuable excipient. It is a clear, colorless, and odorless liquid hydrocarbon that serves as an excellent emollient and solvent in skincare and pharmaceutical formulations.[4] Its lightweight, non-greasy texture, high spreadability, and ability to facilitate quick drying make it ideal for use in topical creams, lotions, and other drug delivery systems.[5][6] In the pharmaceutical industry, iso-dodecane is utilized as a solvent for various drug formulations, aiding in the creation of liquid dosage forms.[5] This document provides detailed protocols for the synthesis of a suitable catalyst and the subsequent isomerization process, along with a summary of relevant performance data.

## Reaction Mechanism and Pathways

The hydroisomerization of n-alkanes like dodecane over a bifunctional catalyst proceeds through a well-established mechanism involving both metal and acid sites.[7] The process requires a noble metal (typically platinum) for hydrogenation/dehydrogenation functions and an acidic support (such as a zeolite) for skeletal isomerization.

The key steps are:

- Dehydrogenation: The linear alkane (n-dodecane) is first dehydrogenated on a metallic site (e.g., Platinum) to form an alkene intermediate (dodecene).[8]
- Carbenium Ion Formation: The alkene diffuses to an acid site on the support (e.g., a Brønsted acid site on a zeolite), where it is protonated to form a secondary carbenium ion.[8]
- Skeletal Isomerization: The carbenium ion undergoes a series of skeletal rearrangements (e.g., methyl and ethyl shifts) to form more stable tertiary carbenium ions, which correspond to branched structures.
- Deprotonation: The branched carbenium ion is deprotonated at an acid site to form a branched alkene (iso-dodecene).
- Hydrogenation: The iso-dodecene diffuses back to a metallic site where it is hydrogenated to the final product, a branched alkane (iso-dodecane).[8]

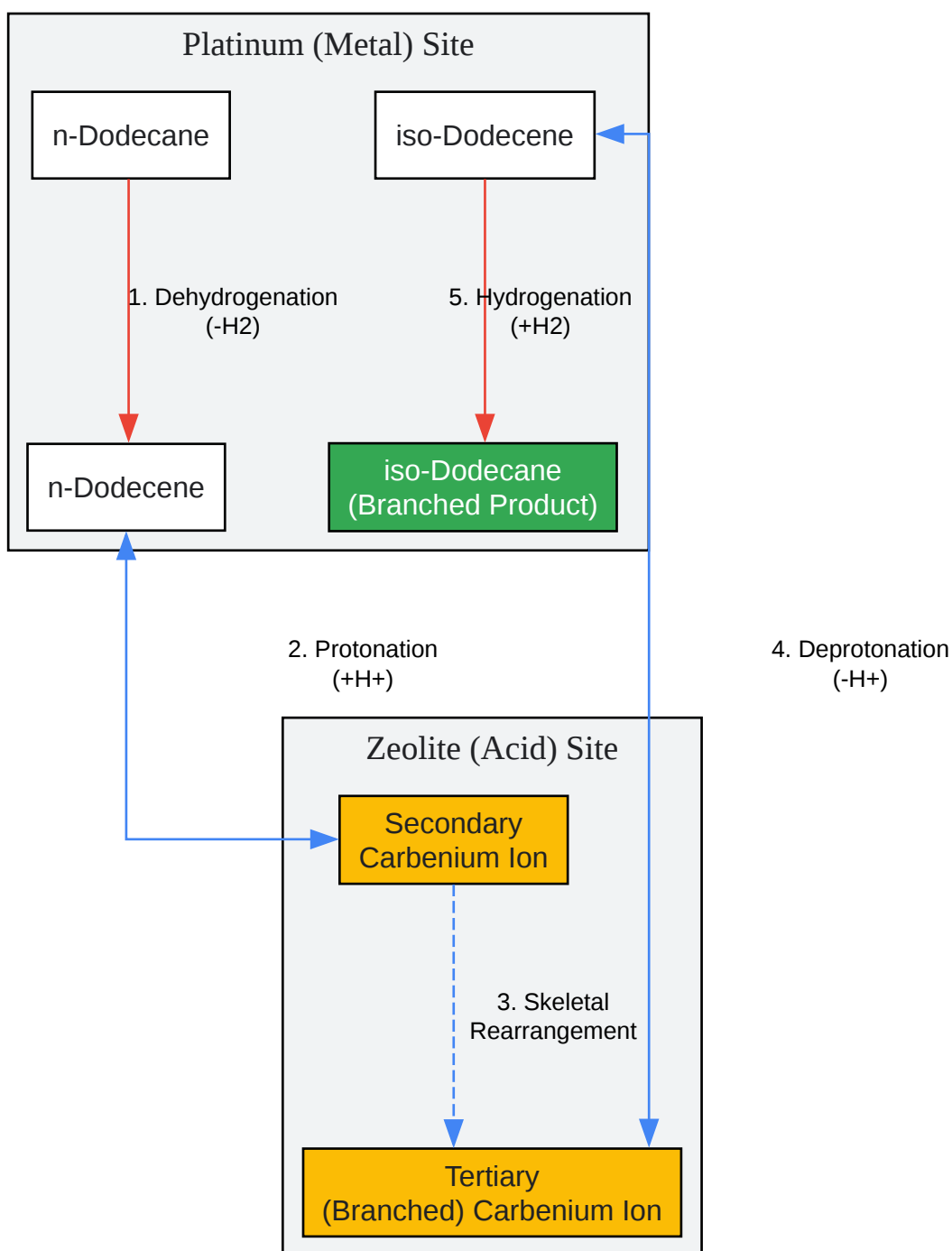

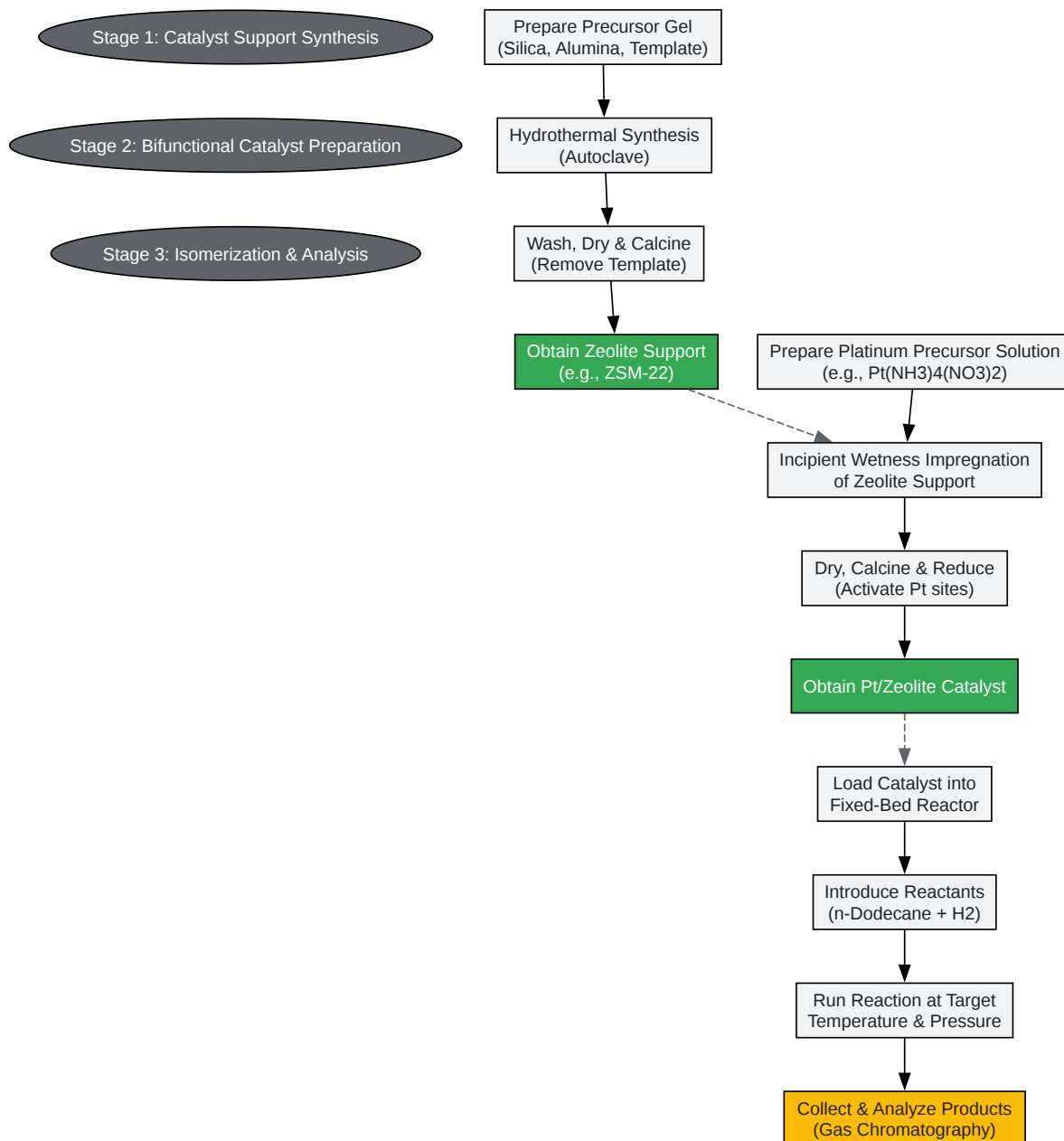

[Click to download full resolution via product page](#)

### Need Custom Synthesis?

BenchChem offers custom synthesis for rare earth carbides and specific isotopic labeling.

Email: [info@benchchem.com](mailto:info@benchchem.com) or [Request Quote Online](#).

## References

- 1. List of isomers of dodecane - Wikipedia [en.wikipedia.org]
- 2. haltermann-carless.com [haltermann-carless.com]
- 3. Dodecane, mixture of isomers | Fisher Scientific [fishersci.ca]
- 4. Research on Isododecane: Protection and Application\_Chemicalbook [chemicalbook.com]
- 5. Isododecane | CAS 31807-55-3 | Manufacturer, Supplier, Exporter [emcochemicals.com]
- 6. Isododecane Manufacturer & Suppliers |ELFAT-iDCane - Elchemy [elchemy.com]
- 7. pubs.acs.org [pubs.acs.org]
- 8. academic.oup.com [academic.oup.com]
- To cite this document: BenchChem. [Application Notes & Protocols: Catalytic Isomerization of Linear Dodecane to Branched Isomers]. BenchChem, [2025]. [Online PDF]. Available at: [https://www.benchchem.com/product/b14535098#catalytic-isomerization-of-linear-dodecane-to-branched-isomers]

---

### Disclaimer & Data Validity:

The information provided in this document is for Research Use Only (RUO) and is strictly not intended for diagnostic or therapeutic procedures. While BenchChem strives to provide accurate protocols, we make no warranties, express or implied, regarding the fitness of this product for every specific experimental setup.

**Technical Support:** The protocols provided are for reference purposes. Unsure if this reagent suits your experiment? [[Contact our Ph.D. Support Team for a compatibility check](#)]

**Need Industrial/Bulk Grade?** [Request Custom Synthesis Quote](#)

# BenchChem

Our mission is to be the trusted global source of essential and advanced chemicals, empowering scientists and researchers to drive progress in science and industry.

## Contact

Address: 3281 E Guasti Rd  
Ontario, CA 91761, United States  
Phone: (601) 213-4426  
Email: [info@benchchem.com](mailto:info@benchchem.com)