

Application Note: Microwave-Assisted Functionalization of 5-Chloropyrazine-2-carboxylic Acid Hydrazide

Author: BenchChem Technical Support Team. **Date:** May 2026

Compound of Interest

Compound Name:	5-Chloropyrazine-2-carboxylic acid hydrazide
CAS No.:	848952-83-0
Cat. No.:	B1453471

[Get Quote](#)

Strategic Overview

The Scaffold

5-Chloropyrazine-2-carboxylic acid hydrazide is a high-value "privileged structure" in drug discovery, particularly for antitubercular (Pyrazinamide analogs) and antineoplastic research. Its utility lies in its bifunctionality:

- C-2 Hydrazide: A versatile handle for generating heterocycles (1,3,4-oxadiazoles, triazoles) or Schiff bases.
- C-5 Chloride: An electrophilic site primed for Nucleophilic Aromatic Substitution (), activated by the para-located electron-withdrawing carbonyl group.

The Microwave Advantage

Thermal functionalization of electron-deficient pyrazines is notoriously sluggish, often requiring reflux times of 12–48 hours. Microwave-Assisted Organic Synthesis (MAOS) offers a distinct kinetic advantage here. The high polarity of the hydrazide moiety and the transition states involved in

reactions result in a high "loss tangent" (

), allowing for efficient coupling of microwave energy. This reduces reaction times to minutes and suppresses the degradation often seen with prolonged heating of hydrazine derivatives.

Equipment & Safety Protocols

Instrumentation Setup

- **Reactor Type:** Single-mode microwave reactor (e.g., Anton Paar Monowave or CEM Discover) is recommended for high reproducibility and pressure control.
- **Vessel:** 10 mL or 30 mL borosilicate glass vials with crimp/snap caps and PTFE/silicone septa.
- **Temperature Control:** IR sensor is sufficient for standard solvents; however, an internal fiber-optic probe is mandatory if using low-absorbing solvents (e.g., Toluene/Dioxane) or scaling up >5 mmol.

Critical Safety Notice

- **Hydrazine Risks:** Hydrazide derivatives can release hydrazine or nitrogen gas upon decomposition. Do not exceed 200°C. Ensure the pressure cutoff is set to 20 bar.
- **Vessel Headspace:** Maintain a liquid-to-headspace ratio of 1:1 to accommodate potential gas evolution during cyclization.

Experimental Protocols

This guide details a divergent workflow: Path A (Hydrazone/Oxadiazole formation) and Path B (displacement).

Path A: C-2 Functionalization (Schiff Base & Cyclization)

Protocol A1: Rapid Synthesis of Pyrazine-Hydrazones (Schiff Bases)

Target: Condensation of 5-chloro-pyrazine-hydrazide with aromatic aldehydes.

Reagents:

- **5-Chloropyrazine-2-carboxylic acid hydrazide** (1.0 equiv)
- Aromatic Aldehyde (1.1 equiv)
- Solvent: Ethanol (EtOH) or Methanol (MeOH)
- Catalyst: Glacial Acetic Acid (1-2 drops)

Step-by-Step:

- **Dissolution:** In a 10 mL MW vial, dissolve 1.0 mmol of the hydrazide in 3 mL of EtOH.
- **Addition:** Add 1.1 mmol of the aldehyde and 2 drops of acetic acid. Cap the vial.
- **Irradiation:**
 - Temperature: 90°C
 - Time: 5–10 minutes
 - Stirring: High (600 rpm)
- **Workup:** Cool to 50°C using compressed air. The product usually precipitates upon cooling. Filter, wash with cold EtOH, and dry.

Protocol A2: Oxidative Cyclization to 1,3,4-Oxadiazoles

Target: Conversion of Hydrazone (from A1) to 2,5-disubstituted-1,3,4-oxadiazole.

Rationale: Traditional cyclization uses

(corrosive, dangerous in MW). We utilize a hypervalent iodine approach, which is safer and highly efficient under MW irradiation.

Reagents:

- Pyrazine-Hydrazone intermediate (1.0 equiv)
- Iodobenzene diacetate [PhI(OAc)₂] (1.1 equiv)
- Solvent: Dichloromethane (DCM) or Ethanol (EtOH)

Step-by-Step:

- Prep: Suspend 0.5 mmol of hydrazone in 3 mL of solvent in a 10 mL vial.
- Add Oxidant: Add 0.55 mmol PhI(OAc)₂.
- Irradiation:
 - Temperature: 80°C (if EtOH) or 50°C (if DCM - Pressure Watch!)
 - Time: 5 minutes
- Workup: Evaporate solvent. Triturate residue with hexanes to remove iodobenzene by-product. Recrystallize from EtOH.

Path B: C-5 Functionalization ()

Protocol B1: Amination of the Pyrazine Core

Target: Displacement of the 5-Chloro group with secondary amines (e.g., Morpholine, Piperazine).

Mechanistic Insight: The 2-hydrazide group is electron-withdrawing, activating the 5-position. However, the hydrazide protons are acidic. We use a polar aprotic solvent to maximize the nucleophilicity of the amine and the microwave absorption.

Reagents:

- **5-Chloropyrazine-2-carboxylic acid hydrazide** (1.0 equiv)

- Secondary Amine (2.0 equiv) - Excess acts as base and nucleophile
- Solvent: DMSO or DMF (High for rapid heating)
- Base: DIPEA (1.0 equiv) - Optional if amine is valuable

Step-by-Step:

- Prep: Dissolve 0.5 mmol substrate in 2 mL DMSO.
- Irradiation:
 - Temperature: 130°C
 - Time: 10–15 minutes
 - Ramp: 2 minutes to target.
- Workup: Pour reaction mixture into 15 mL ice water. The amino-pyrazine usually precipitates. If not, extract with EtOAc.

Data Summary & Comparison

Table 1: Microwave vs. Thermal Efficiency

Reaction Type	Target Product	Thermal Conditions	MW Conditions	Yield (MW)	Time Reduction
Condensation	Hydrazone	Reflux EtOH, 4–6 h	90°C, 5 min	92–96%	50x
Cyclization	1,3,4-Oxadiazole	Reflux, 8–12 h	PhI(OAc) ₂ , 80°C, 5 min	85–90%	90x
	5-Amino-Pyrazine	Reflux Toluene, 24 h	DMSO, 130°C, 15 min	78–85%	96x

Visualized Workflows

Reaction Pathway Logic

This diagram illustrates the divergent synthesis options available from the core scaffold.

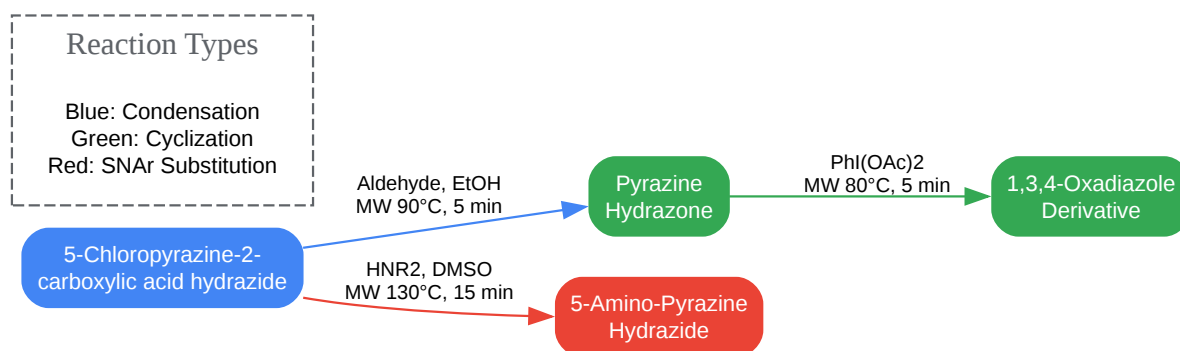

[Click to download full resolution via product page](#)

Figure 1: Divergent synthetic pathways for **5-chloropyrazine-2-carboxylic acid hydrazide**.

Experimental Workflow (Protocol A2)

A visual guide for the oxidative cyclization protocol.

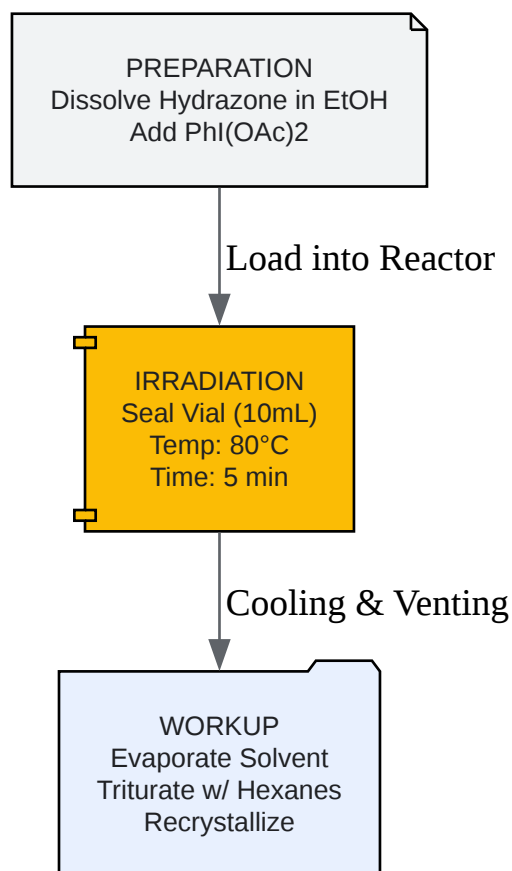

[Click to download full resolution via product page](#)

Figure 2: Step-by-step workflow for the microwave-assisted oxidative cyclization.

References

- Microwave-Assisted Synthesis of 1,3,4-Oxadiazoles
 - Desai, N. C., et al. "Microwave assisted synthesis of some new 1,3,4-oxadiazole derivatives bearing pyridine nucleus and their antimicrobial activity." *Indian Journal of Chemistry*, 2016.
 - Source:
- Pyrazine Hydrazone Chemistry (Antitubercular Context)
 - Sahoo, B. M., et al. "Microwave-assisted Green Synthesis: An Approach for the Development of Anti-tubercular Agents." [1][2] *Current Drug Targets*, 2025.

- Source:[1]
- Reactions in Microwave:
 - General Protocol for Chloropyrazine Amination: "Microwave-Assisted Amination of a Chloropurine Derivative." (Analogous chemistry for electron-deficient chloro-heterocycles).
 - Source:
- Kumar, D., et al. "Iodobenzene diacetate mediated synthesis of 1,3,4-oxadiazoles under microwave irradiation." Synlett, 2004.

Need Custom Synthesis?

BenchChem offers custom synthesis for rare earth carbides and specific isotopic labeling.

Email: info@benchchem.com or [Request Quote Online](#).

Sources

- [1. Microwave-assisted Green Synthesis: An Approach for the Development of Anti-tubercular Agents - PubMed \[pubmed.ncbi.nlm.nih.gov\]](#)
- [2. researchgate.net \[researchgate.net\]](#)
- To cite this document: BenchChem. [Application Note: Microwave-Assisted Functionalization of 5-Chloropyrazine-2-carboxylic Acid Hydrazide]. BenchChem, [2026]. [Online PDF]. Available at: [<https://www.benchchem.com/product/b1453471/docs#application-note-microwave-assisted-functionalization-of-5-chloropyrazine-2-carboxylic-acid-hydrazide>]

Disclaimer & Data Validity:

The information provided in this document is for Research Use Only (RUO) and is strictly not intended for diagnostic or therapeutic procedures. While BenchChem strives to provide accurate protocols, we make no warranties, express or implied, regarding the fitness of this product for every specific experimental setup.

Technical Support: The protocols provided are for reference purposes. Unsure if this reagent suits your experiment?

Need Industrial/Bulk Grade? [Request Custom Synthesis Quote](#)

BenchChem

Our mission is to be the trusted global source of essential and advanced chemicals, empowering scientists and researchers to drive progress in science and industry.

Contact

Address: 3281 E Guasti Rd
Ontario, CA 91761, United States
Phone: (601) 213-4426
Email: info@benchchem.com

[Contact our Ph.D. Support Team for a compatibility check](#)